



*Powering Business Worldwide*

**SM64167**

September 2004

Applicable additional manuals:

None

Aerospace Group  
Conveyance Systems Division  
Carter<sup>®</sup> Brand Ground Fueling Equipment

Maintenance & Repair Manual

---

## **3" & 5-1/4" Inward Opening Vents**

---

**Model 64167**

**Model 64168**

**Table of Contents**

	Page
1.0 Introduction .....	3
2.0 Equipment Description.....	3
3.0 Table of Options and Ordering Information .....	3
4.0 Disassembly .....	3
5.0 Inspection.....	4
6.0 Reassembly .....	4
7.0 Test.....	5
8.0 Illustrated Parts Catalog .....	5
Figure 1 - 64167 5 ¼" .....	6
Figure 2 - 64168 3" .....	8

**Maintenance, Overhaul & Test Instructions  
Carter® Model 64167 & Model 64168 Inward Opening Vents**

**1.0 INTRODUCTION**

This manual furnishes detailed instructions covering the maintenance and overhaul of Eaton's Carter brand Model 64167 and Model

64168 inward opening vents and the various options listed in Section 3.0.

**2.0 EQUIPMENT DESCRIPTION**

Carter Model 64167 5-¼" and Model 64168 3" inward opening vents are offered to meet the latest 406 and 407 Department of Transportation (DOT) requirements. By using an inward opening vent, the poppet will not come open under "roll over" situations, unlike the older outward opening vents.

The basic vents can be procured under model numbers 64167 or 64168 with various options as noted in paragraph 3.0 and the figures at the end of this manual.

**3.0 TABLE OF OPTIONS AND ORDERING INFORMATION**

Models 64167 & 64168 are available with various options as outline below.

**OPTIONS TO BE ADDED TO 64167 5-¼" Vent** – basic part number is an air operated, inward opening vent with standard TTMA mounting and includes Buna N seals, and an aluminum hood with two 3-½" victaulic opposed outlets for vapor recovery. Another standard feature is the capability of including an internal valve interlock. When plumbed using this feature, the internal valve will not open unless the vent opens.

**OPTION D** – Changes standard Buna N seals to Viton.

**OPTIONS TO BE ADDED TO 64168 3" Vent** – basic part number is a mechanically operated, inward opening vent with standard 3" TTMA mounting and includes Buna N seals, an aluminum vapor recovery hood with a single 3" victaulic outlet, and capability to connect to a rod from the internal valve that provides the opening force. The following options are available to change the vent to suit the situation:

Option Letter	Description	Option Letter	Description
A	Changes the standard hood and mounting to mate the obsolete OPW 3" vent – 5.375" dia. bolt circle with 6-.395 dia. mounting holes	B	Changes the standard hood and mounting to mate 4" TTMA mounting
D	Replaces Buna N seals with Viton	E	Adds adjustable linkage assembly with connecting rod to be used with Carter Model 64129 bottom loading valve

Example: 64167D – 5 ¼" inward opening vent with Viton seals in lieu of Buna N  
64168BE – 3" Inward opening vent to mate a standard 4" TTMA mounting with an adjustable linkage to mate Carter Model 64129 bottom loading valve

**4.0 DISASSEMBLY**

**4.1 64167 5 ¼" Vent**

- 4.1.1 Remove Screws (1-1) and Washers (1-2) and pull off Housing (1-3). It may be necessary to twist and pull as the housing is being removed.
- 4.1.2 Remove and discard O-Ring (1-4).
- 4.1.3 Remove Screws (1-5). Pull off Upper Vent Housing (1-6). Set the housing aside.
- 4.1.4 Remove and discard O-Ring (1-7).

**CAUTION**  
The vent spring has considerable force, so care must be exercised in following the next steps.

- 4.1.5 Hold one of the two Screws (1-8) and slowly remove the other. Remove Washer (1-9). The heavy spring will force the parts apart as they are being loosened, so observe care.

- 4.1.6 Remove Piston (1-10) and discard O-Ring (1-11). Remove and discard O-Ring (1-12)
- 4.1.7 Remove Poppet (1-13) and set it aside.
- 4.1.8 Remove Spring (1-14) and set it aside.
- 4.1.9 Pull Shaft (1-15) from unit.
- 4.1.10 Remove and discard remaining two O-rings (1-12) from the shaft.
- 4.1.11 It is not necessary to remove Screws (1-18) or Screen (1-21) unless damage is noted.
- 4.2 64167 3" Vent
- 4.2.1 Remove Screws (2-1) that hold the Upper Vent Housing to the Lower Vent Housing. Separate Upper Housing (2-2) and remove and discard O-Ring (2-3).
- 4.2.2 Using an Allen Key remove Screw (2-4) through hole in lower stem of Lower Housing (2-5).
- 4.2.3 Remove the second Screw (2-4) from the center of the scissor mechanism through the Pivot Shaft (2-6).
- 4.2.4 Remove Cotter Keys (2-7) and push out Pivot Shaft (2-6). This frees the scissor mechanism to allow removal it from the unit. Unless this mechanism is damaged there is no need to disassemble it further.
- 4.2.5 The poppet assembly can then be removed from the unit from the top. Remove Cotter Key (2-8), then Poppet (2-9). Remove the Spring (2-10) and Shaft (2-11). Set them aside.
- 4.2.6 If the scissor mechanism is to be disassembled, note that Screws (2-13) and Screws (2-14) are provided with a shoulder to prevent over tightening. Remove the screws and Nuts (2-15) to disassemble the mechanism. Remove the Washers (2-15). There are four each primary Links (2-16) and secondary Links (2-17). Note how the mechanism is assembled, especially the Washers (2-15), before removing. In addition, there are two pivot Blocks (2-16) located at the top and bottom of the mechanism to accept the links.
- 4.2.7 It is not necessary to remove Screws (2-21) or Screen (2-22) unless damage is noted.
- 4.2.8 Option E (if present) (no pictorial breakdown presented) – The connecting rod is a tube used to connect the Carter 64168 Vent to 64129 Internal Valve. The Cotter Key (3-1) is used to connect it to the shaft on top of the 64129. The other end of the Connecting Rod (3-2) is internally threaded to accept the Stud (3-3). Two Jam Nuts (3-4) are provided to lock the adjustment in length of the rod. The 0.375" diameter shaft of the scissor mechanism on the 64168 vent fits inside of the stud.

## 5.0 INSPECTION

It is recommended that O-rings (1-6), (1-10), (1-11) and (2-3) be discarded and replaced at each overhaul.

Inspect all metal parts for dings, gouges, abrasions, etc. Use 320 grit paper to smooth and remove sharp edges. Replace any part with damage exceeding 15% of local wall thickness. Use Alodine 1200 to touch up bared aluminum.

Inspect molded seals on Poppets (1-12) and (2-9) be inspected for any cuts or missing rubber sections. Check carefully with a fingernail to be sure that the rubber is still resilient by

depressing it about 1/32" and releasing it. If there is not imprint left and the rubber returns to normal, it is fine to use again. If it does not return or is permanently marked by this action, replace the poppet.

Check the screen on the vent inlet for any damage and replace if necessary.

On 64168 Vent check scissor mechanism for any damage and replace if necessary.

If Option E is present, check any damage and replace as necessary.

## 6.0 REASSEMBLY

Reassemble the parts in the reverse order of disassembly noting the following:

- 6.1 Make certain all components are clean and free from oil, grease, or any other corrosion resistant compound on all interior or exterior surfaces. Wash all parts with cleaning solvent, Federal Specification P-D-680, and dry thoroughly with a clean, lint-free cloth or compressed air.

### WARNING

Use cleaning solvent in a well-ventilated area. Avoid breathing of fumes and excessive solvent contact with skin. Keep away from open flame.

- 6.2 Take caution in replacing parts joined by O-rings to prevent cutting them during assembly. Lubricate the O-rings with petroleum jelly.

6.3 Where cotter pins are used (64168), be sure to bend the ends flat against the adjoining surface to retain properly.

6.4 If the screen is removed from either vent, use Locktite #242 on the mounting screws to retain.

## 7.0 TEST

7.1 The following test procedures shall be accomplished after overhaul:

flange of the unit). The poppet should start to crack open.

### 7.2 Test conditions

Test media shall be JP-8 MIL-T-83133, Jet A, odorless kerosene or Stoddard type solvent MIL-PRF-7024E Type II.

7.3.1.2 Increase the pressure to 24 psi and the poppet should be fully open. To be sure it is open, increase pressure to 30 psi and observe the poppet. It should not move any further open. If it does then the spring is faulty.

### 7.3 Functional Test

7.3.2 64168 Vent

7.3.1 64167 Vent

Actuate the mechanism by hand to be sure it opens the vent smoothly and retracts when the force to open it is removed.

7.3.1.1 Apply air pressure of 18 psig to the vent actuation port (port closest to the mounting

## 8.0 ILLUSTRATED PARTS CATALOG

Table 1.0 tabulates the parts and sub-assemblies comprising the 64167 Vent. The item numbers of the table are keyed to the exploded views of the 64167 Vent diagrammed in Figure 1.

**Table 1.0**  
Ref. Figure 1

Fig.	Item	Part Number	Description	Units/ Assy	Option	Spares/10 Units/Yr
1	1	GF35307-306	Screw	4	All	-
	2	GF35333-40	Washer	4	All	-
	3	221531	Housing	1	All	-
	4	MS29513-149	O-Ring, Buna N	1	Basic	10
		M83248/1-149	O-Ring, Viton	1	D	10
	5	GF24693-C72	Screw	2	All	-
	6	221528	Upper Housing	1	All	-
	7	MS29513-161	O-Ring, Buna N	1	Basic	10
		M83248/1-161	O-Ring, Viton	1	D	10
	8	220698	Screw	2	All	-
	9	GF35333-40	Washer	2	All	-
	10	221532	Piston	1	All	-
	11	MS29513-227	O-Ring, Buna N	1	Basic	10
		M83248/1-227	O-Ring, Viton	1	D	10
	12	MS29513-013	O-Ring, Buna N	3	Basic	30
		M83248/1-013	O-Ring, Viton	3	D	30
	14	47405-1	Poppet, Buna N	1	Basic	2
		47405-2	Poppet, Viton	1	D	2
	15	220700	Spring	1	All	-
	16	221530	Shaft	1	All	-
	17	221529	Lower Housing	1	All	-
	18	GF51957-13	Screw	2	All	-
	19	Left intentionally blank				
	20	#242	Locktite	A/R	All	-
	21	221533	Screen	1	All	-

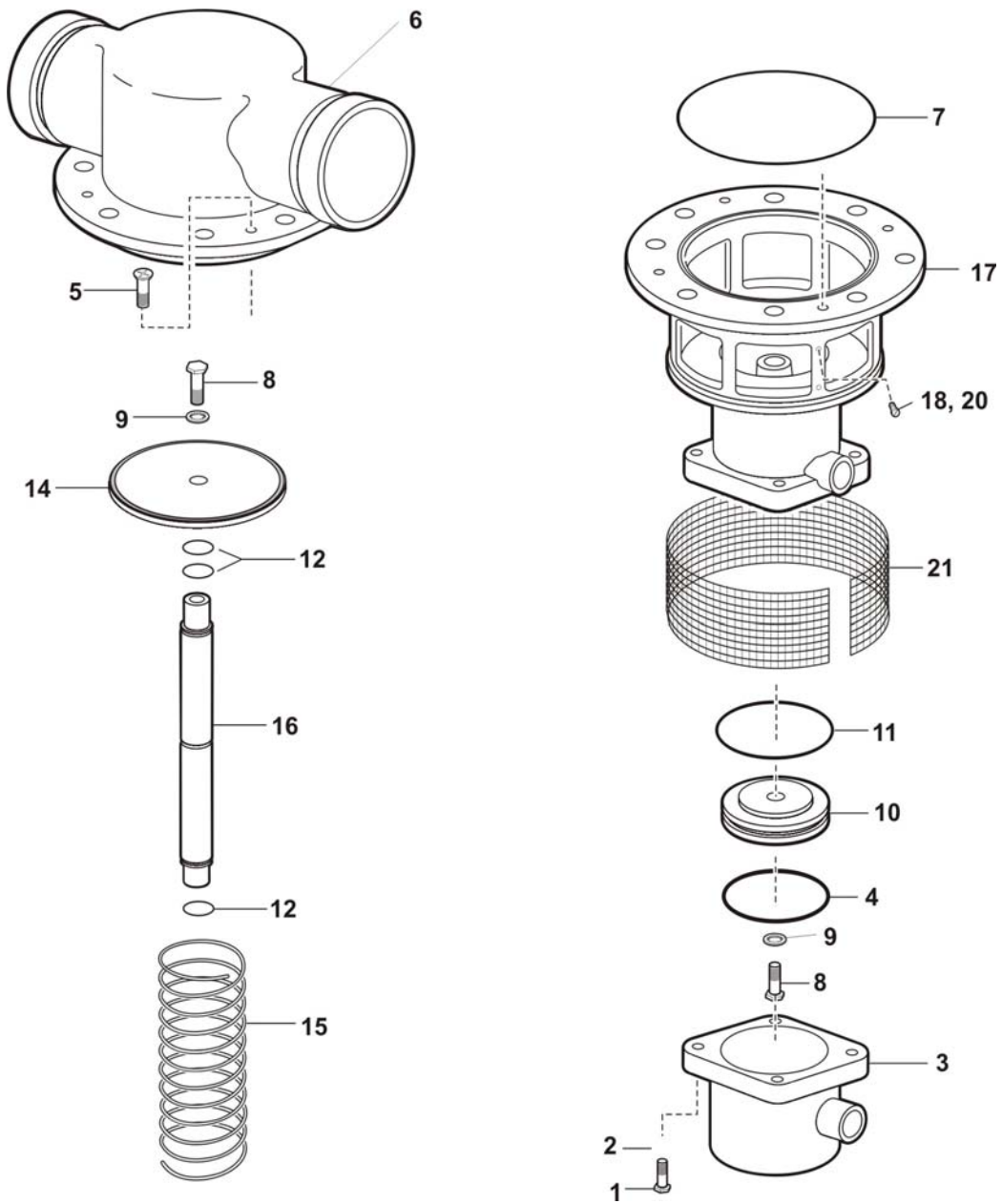
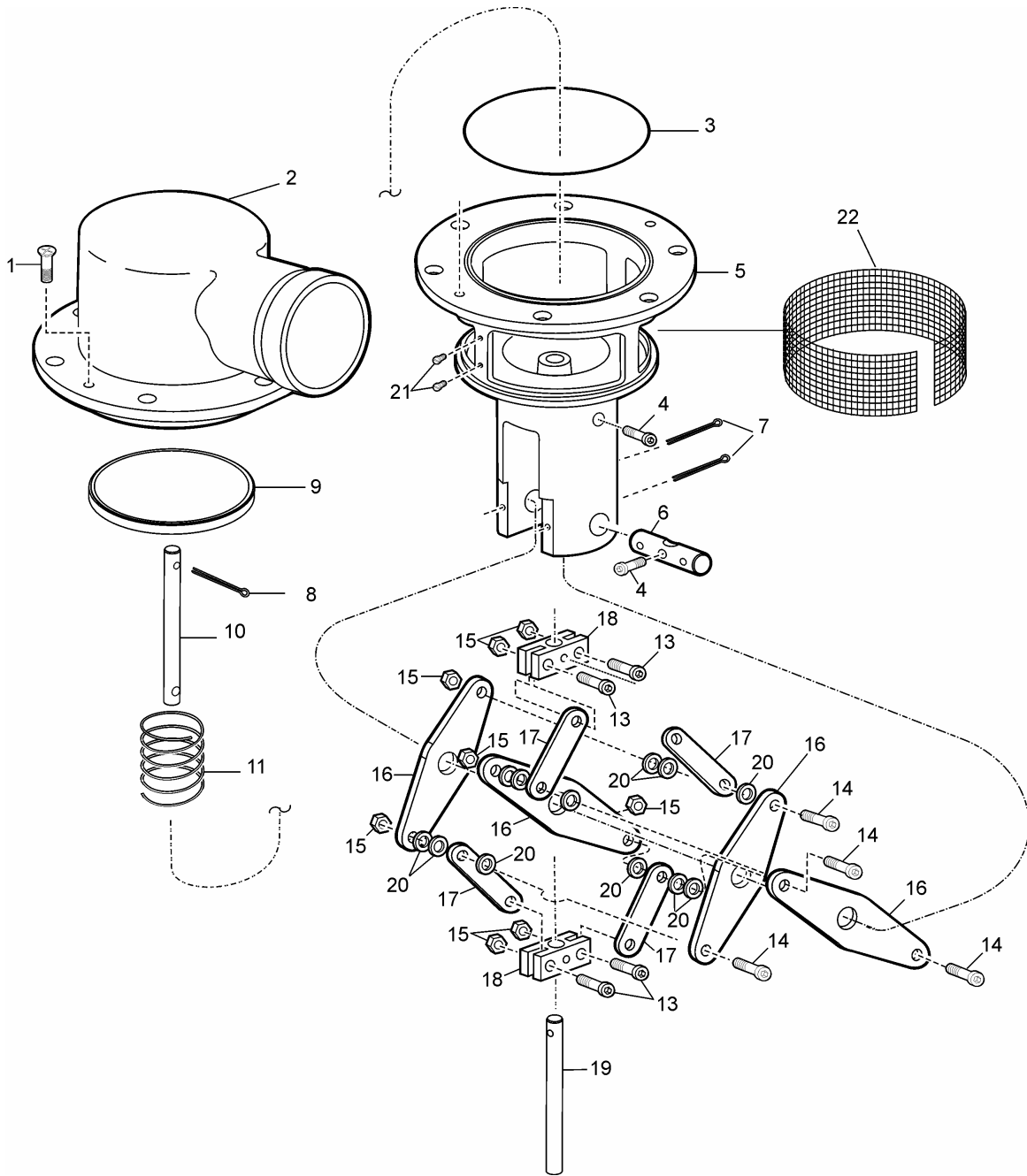

Figure 1  
64167 5 1/4" VENT BREAKDOWN

**Table 2.0**  
Ref. Figure 2

Fig.	Item	Part Number	Description	Units/ Assy	Option	Spares/10 Units/Yr
2	1	22GF24693-C72	Screw	2	All	-
	2	221518	Upper Housing	1	Basic	-
		221541	Upper Housing	1	A	-
		221661	Upper Housing	1	B	-
3		MS29513-154	O-Ring, Buna N	1	All but D	10
		M83248/1-154	O-Ring, Viton	1	D	10
4		GF16996-11	Screw	2	All	-
5		221519	Lower Housing	1	Basic	-
		221542	Lower Housing	1	A	-
		221662	Lower Housing	1	B	-
6		221523	Pivot Shaft	1	All	-
7		GF24665-376	Cotter Key	3	All	4
8		Left intentionally blank				
9		47404-1	Poppet, Buna N	1	All but D	-
		47404-2	Poppet, Viton	1	D	-
10		221543	Shaft	1	All	-
11		S-1294	Spring	1	All	-
12		Left intentionally blank				
13		GF51576-21	Screw	4	All	-
14		GF51576-22	Screw	4	All	-
15		GF21083C3	Nut	8	All	-
16		221521	Primary Link	4	All	-
17		221522	Secondary Link	4	All	-
18		221524	Pivot Block	2	All	-
19		221526	Shaft	1	All	-
20		5610-293-125	Washer	12	All	12
21		GF51957-13	Screw	2	All	-
22		221544	Screen	1	All	-
23		#242	Locktite	A/R	All	-



**Figure 2**  
**64168 3" Vent Breakdown**



**Table 3.0**  
Interconnecting Rod Assembly for Connecting to 64129 Internal Valve

<b>Figure</b>	<b>Item</b>	<b>Part Number</b>	<b>Description</b>	<b>Units/ Assy</b>	<b>Option</b>	<b>Spares/10 Units/Yr</b>
None	1	18724PC188	Cotter Key	1	E	-
	2	221503	Connecting Rod	1	E	-
	3	221599	Stud	1	E	-
	4	62NHH188	Nut	2	E	-

Aerospace Group  
Conveyance Systems Division  
9650 Jeronimo Rd  
Irvine, CA 92618  
Ph (949) 452-9500  
Fax (949) 452-9992



*Powering Business Worldwide*