



Powering Business Worldwide

Aerospace Group
Conveyance Systems Division
Carter® Ground Fueling

SM64804

June 2014

Applicable additional manuals:
None

Maintenance & Repair Manual

**3 X 4 Inch Hydrant Coupler
To Mate Hydrants in Accordance with Bulletin API 1584**

Model 64804

TABLE OF CONTENTS

	PAGE
1.0 INTRODUCTION.....	3
2.0 EQUIPMENT DESCRIPTION	3
3.0 TABLE OF OPTIONS AND ORDERING INFORMATION	3
4.0 OPERATION	4
5.0 SAFETY INFORMATION - PERIODIC INSPECTIONS	6
6.0 TROUBLE SHOOTING AND MINOR REPAIR	10
7.0 INSTALLATION.....	13
8.0 SPECIAL TOOLS.....	15
9.0 DISASSEMBLY.....	15
10.0 INSPECTION AND REPAIR	19
11.0 REASSEMBLY.....	21
12.0 TESTING.....	25
13.0 STORAGE.....	26
14.0 ILLUSTRATED PARTS CATALOG.....	26
FIGURE 1 - 64804 HYDRANT COUPLER & OPTIONS	28
FIGURE 2 - 64804 LOWER COUPLER HALF ASSEMBLY.....	30
FIGURE 3 - PRESSURE CONTROL ELBOW ASSY FOR 64804	32
FIGURE 4 - EXCESS FLOW CONTROL DEVICE.....	34
FIGURE 5 - OPTION 2 QUICK DISCONNECT ASSEMBLIES	37
FIGURE 6 - OPTION 3 QUICK DISCONNECT ASSEMBLIES	38
FIGURE 6A - OPTION 3 QUICK DISCONNECT ASSEMBLIES.....	38
FIGURE 7 - OPTION 4 QUICK DISCONNECT ASSEMBLIES	39
FIGURE 7A- OPTION 4 QUICK DISCONNECT ASSEMBLIES	39
FIGURE 8 - COLLAR STOP LOCK ASSEMBLY	40
FIGURE 8A – OPTION G MOUNTING INSTRUCTIONS	41
FIGURE 9 - CARRIAGE ASSEMBLY	42
FIGURE 9A - CARRIAGE INSTALLATION INSTRUCTIONS	43
FIGURE 10 - STANDARD TRANSVERSE CARRYING HANDLE	44
FIGURE 11 - OPTION Y CARRYING HANDLE.....	45
FIGURE 12 - INNER SEAL POLISHING TOOL.....	46
FIGURE 13 - INNER SEAL POLISHING TOOL.....	47
15.0 OBSOLETE PARTS INFORMATION.....	47

**Maintenance, Overhaul & Test Instructions
3 X 4 Inch Hydrant Coupler
To Mate Hydrants in Accordance with Bulletin API 1584**

Model 64804

1.0 INTRODUCTION

This manual furnishes instructions for the installation, operation, periodic inspection, trouble shooting and minor repair, as well as complete overhaul of Eaton's Carter brand Model 64804 digital fuel pressure control coupler with excess flow control and its various options designed to mate hydrant valves built in accordance with API Bulletin 1584.

Maintenance and overhaul of repairable subassemblies, including all the various options are also included.

The last section of this manual contains exploded view drawings and assembly drawings for identification of replaceable parts and other significant maintenance items referred to in the instructions. References in the text to various items refer to the appropriate figure for part identification.

2.0 EQUIPMENT DESCRIPTION

The standard Eaton Carter brand Model 64804 fuel pressure control coupler consists of four basic modules; a standard dry break coupler lower half, a fuel pressure control elbow assembly that contains an excess flow control device and various female disconnects as explained below. Other options are available as explained further in the following table.

The coupler is designed to mate with standard 4-inch hydrant valves that conform to API Bulletin 1584.

The 47245 lower half coupler with standard folding handle assembly provides a quick means to connect to a hydrant with dry break capability. The coupler can not be opened unless it is connected to a valve; it cannot be removed from that valve unless it is in the closed position.

The unit incorporates a mechanically operated relief valve that is automatically opened by the coupler when the coupler poppet is closed providing a vent to the downstream side of the main piston seat, relieving a hydraulic lock that would otherwise prevent coupler poppet closing. The spring-loaded relief valve also relieves automatically whenever the differential pressure across the closed pressure control piston seat exceeds approximately 220 psi in the inlet to outlet direction.

The Pressure Control Elbow Assembly is a direct operated normally closed fuel pressure control and shutoff valve. It is controlled by a remotely mounted set of solenoid valves, 64102 and an Eaton Carter brand digital pressure control system, Digital II 64235 or Digital III 64335. The 64102 provides fuel pressure to the coupler upon commands from the digital pressure control system. The application of the fuel pressure overrides the piston spring, which is opposed by atmospheric pressure. The digital pressure control system through the two-solenoid valves on the 64102 controls the pressure applied to the piston to position it in the desired position to control the pressure sensed at the 64108 pressure transducer. There is only one hose needed from the vehicle to the coupler to control the pressure unlike with the air reference type system that requires both an air reference hose and a fuel control hose. Excess flow control is achieved by sensing the pressure differential across two internal points within the pressure control elbow. If the pressure exceeds a preset and adjustable point, the coupler is automatically closed and remains closed until it is manually reset.

There are no adjustments for opening, closing or bias on the coupler. All of these are handled by the digital pressure control system. The adjustment for the excess flow control is handled on the coupler.

3.0 TABLE OF OPTIONS AND ORDERING INFORMATION

The basic unit 64804 is available with a variety of options to customize it to meet specific requirements as listed in Table 1 below. The various options, when

compatible, may be combined and listed following the part number 64804 to achieve a complete unit.

The part numbering system for the coupler is as follows with the options noted in the tables below:

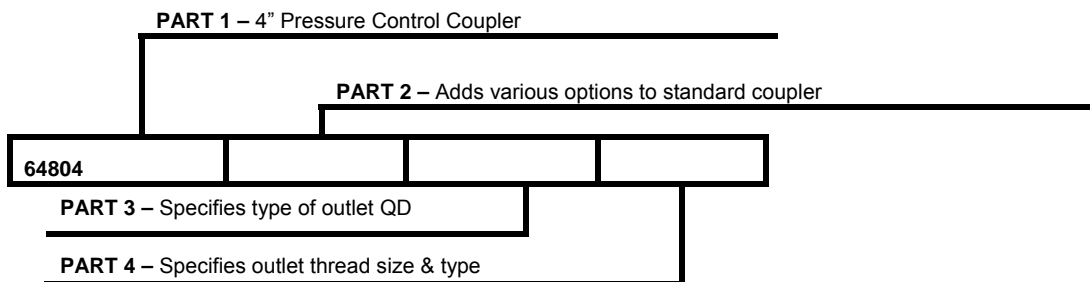

PART 2

OPTION	DESCRIPTION	OPTION	DESCRIPTION
A	*Changes lugs to API/EI 1584, 2 nd edition	F	Adds male dry break quick disconnect for the fuel control port – Use with Option E.
C	Adds product selection	W	Adds carriage assembly
D	Adds lockwire to flange joints	X	Adds safety clip to QD (with option 2 only)
E	Adds Female Dry Break Coupling for use on sense hose. - Use with Option F.	Y	Adds second carrying handle at outlet swivel joint

* Refer to Product News Bulletin PN6490001020 for a complete description of this change before ordering. Changes lugs to part number 200688 (2nd edition) in lieu of part number 221860 (3rd edition)

PART 3

OPTION	DESCRIPTION
2	Adds Adapter to mate with 47152 or 47292 thumb latch QD
3	Adds Adapter to mate with 60700-1 type QD (41730)
4	Adds Adapter to mate with 60600 (except option K) type QD (44220)

PART 4

(Applicable only as shown below)

OPTION	DESCRIPTION	OPTION	DESCRIPTION
H	2 ½" NPT outlet – Applicable only with option 2 above.	P	4" NPT outlet – Applicable with options 2, 3 & 4 above.
K	2 ½" BSPP outlet – Applicable only with option 2 above.	Q	2" NPT outlet - Applicable only with option 2 above.
L	3" NPT outlet – Applicable with options 2, 3 & 4 above.	R	4" NPSC outlet – Applicable only with option 3 above.
M	3" BSPP outlet – Applicable with options 2, 3 & 4 above.	S	2" BSPP outlet - Applicable only with option 2 above.
N	4" BSPP outlet – Applicable with options 2, 3 & 4 above.		

Example: 64804W3L – A coupler with excess flow control, a standard folding handle, standard collar stop assembly, carriage assembly and a 60700-1 type outlet swivel quick disconnect (41730) with 3" NPT threads.

4.0 OPERATION

Operation consists of:

- Connecting the coupler to the hydrant pit valve adapter. If the fuel pressure control hose is used with Option E and F dry break disconnects, they must also be connected.
- Opening coupler by rotating crank handle.
- Activating the deadman to allow flow through the open coupler and valve for the required period;
- Closing the pressure control valve by releasing the deadman control and
- Disconnecting the coupler from the hydrant adapter. Disconnect the fuel hose dry break for storage if present (Option E and F).

Operation may also include reverse flow through the unit for off-loading or defueling purposes.

4.1 COUPLER CONNECTION

Connection of the coupler to the four-inch API-type adapter is simply accomplished. Proceed as follows:

- Remove the dust cap assembly and place the face of the coupler assembly over the pit valve adapter. Use one hand to overcome hose weight bending forces so the coupler face is centered and square to the adapter face. Normally the weight of the coupler, when properly aligned, will cause the spring loaded detent pin to be depressed by the adapter flange, permitting the collar to drop, locking the 16 lugs to the adapter. **If the unit incorporates Option C, Product Selection, it may be necessary to rotate the collar before it can drop. This can be done easily by rotating only the collar. It is not necessary to rotate the coupler body and the servicer pickup hose.**

- With the collar dropped or extended, the poppets may be opened by simply rotating the coupler poppet-operating handle in the open direction as permanently marked on the handle.

Note: It should be understood that the poppet operating linkage is over center with the poppet operating handle in either the full closed or full open position. This feature is required to prevent internal pressure from opening the poppet when the mechanism is in the closed position; and, for that matter, to prevent an external

force from closing the mechanism when it is fully open. Consequently, the initial poppet operating handle open movement causes the poppet to retract slightly into the coupling before moving in the poppet open direction. Further, the poppet operating handle cannot be operated in the open direction if the collar is not extended, or dropped, because of a physical interference between the handle and the collar. At the same time the collar cannot be extended, or dropped unless the spring-loaded detent pin is depressed, normally by the face of the pit valve adapter. Once extended, the collar cannot be retracted if the poppet handle is in other than the full closed position and if the collar stop assembly is not depressed. Together, these features provide safety interlocks that prevent accidental opening of the coupler poppet with the unit disconnected, or disconnection with the poppet open and a potentially hazardous or undesirable product spill.

C. If the adapter is pressurized by hydrant pressure at the time of poppet opening, resistance will be felt when the coupler poppet contacts the adapter poppet. The resistance will be proportional to the hydrant pressure. The force resisting the opening of an Eaton Carter brand hydrant valve is composed of two factors, poppet spring force plus any force created by fuel pressure in the hydrant. The normal spring force is approximately 20 pounds and the pressure force is equal to over 125 pounds for each 10-psi present. In addition to the forces attributed to the hydrant, there are forces presented by the coupler itself. The initial movement of the operating handle to get it **over center** is resisted by a stack of wave washer springs on the nose seal plus seal friction. Under even severe weather conditions, the coupler can be opened by the application of less than 30 pounds force applied to the handle. Since the adapter poppet is equipped with a pressure equalizing valve, maintain a steady, moderate force on the handle in the open direction, sufficient to hold open the adapter pressure equalizing valve until the pressure has equalized across the poppets. Then the handle can be easily moved to the fully open position, permitting full communication between the hydrant adapter and the fuel pressure control valve.

It should be noted that the early release of the API Bulletin 1584 did not cover the need for a pressure-equalizing valve. This resulted in the hydrant valve manufacturers having different dimensions for the location of the operating tip of the valve. There may be some incompatibility between the various older hydrants and couplers if they are intermixed. The result can be either one of considerable leakage during hookup or non-function of the equalizing valve making it very difficult to achieve connection.

Note: The time required for pressure equalizing to occur is contingent on the unfilled downstream volume, the capacity of the adapter pressure equalizing valve, and the hydrant pressure. It is also affected by the amount of leakage through the hydrant piston seals. If it is consistently difficult to open the coupler the hydrant valve maybe "hot" and it should be overhauled.

4.2 FUEL PRESSURE CONTROL VALVE OPERATION

4.2.1 Refueling

Figure A is a schematic diagram of the fuel pressure control elbow assembly module (unit) on which the major functional elements are illustrated and labeled. While Figure A is schematic, the general shapes of the parts have been retained as much as possible to permit a better understanding of the actual hardware.

The inner and outer piston assembly has been split on Figure A for clarity. The lower half illustrates the position of the pistons when the unit is closed, either because deadman has not been activated or because the fuel control pressure is insufficient to overcome the piston spring, and other opening forces that might be present. The upper half of the piston assembly on Figure A illustrates the position of the pistons when the unit is partly open and regulating fuel pressure.

Referring to Figure A while reading this section of the manual should assist in achieving a thorough understanding of the unit operation.

With the coupler engaged and the poppets open, hydrant pressure is available at the unit's outer piston seat. The unit's piston is held normally closed by piston spring force until fuel pressure from the 64102 Solenoid Valve Assembly is applied. This occurs when the deadman connected through the digital pressure control system is activated.

The digital pressure control system will provide the correct amount of pressure to the control port, Port A in Figure 1. This pressure will act against the piston spring and cause the large piston to open allowing flow through the unit. The digital pressure control system will modulate the small piston pressure to the proper amount to maintain the pressure at the pressure transducer (64108) on the vehicle to control the pressure required at the nozzle.

As the receiver aircraft tanks progressively fill and shut off, the flow reductions in each instance cause the pressure to increase at the remote sensing point. These pressure increases are transmitted back through the fuel control hose by the digital pressure control module. The decrease in fuel chamber pressure causes the piston to move in the closed direction. This reduces the outlet pressure, until the fuel pressure transmitted back through the fuel control line has established a new force equilibrium condition about which the piston modulates until the next receiver aircraft tank fills and shuts off.

When the last receiver aircraft tank has shutoff, the conditions described above cause the unit piston to fully close and block hydrant pressure, preventing high pressures from reaching the aircraft manifolds as well as the servicer delivery equipment.

The rapid response inherent in a direct acting regulator combined with the control by the digital pressure control system makes the unit an effective automatic surge control device when fueling aircraft with fast closing (1-2 second) shutoff valves.

Release of the deadman valve at any time will cause the unit to close. The piston closing rate in this mode of operation is also controlled effectively by the digital pressure control system.

An excess flow control device is incorporated within the coupler assembly to sense a flow rate greater than a "preset" value. If this value is exceeded the device will activate and cause the coupler to close. The condition could be due to a ruptured downstream hose which would cause the flow rate to greatly increase over normal. Internal sensing of the flow is achieved by the sensing of the pressure drop across two points within the coupler. The preset value is adjustable within limits and is set by the customer to the desired level. If the device is triggered it can be reset manually by depressing a reset button.

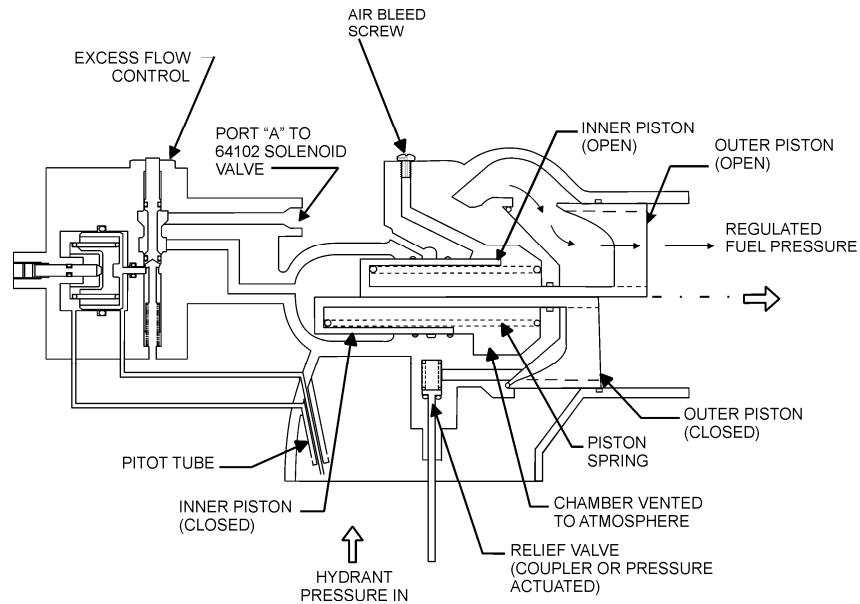

Figure A
Schematic Diagram Pressure Control Elbow Assy

4.2.2 Defueling

Defueling of an aircraft can be accomplished through the unit but all controls are located on the 64235 Digital Pressure Control System. See the appropriate manual for instructions.

4.3 COUPLER DISCONNECTION

Coupler disconnection is essentially the reverse of connection.

Proceed as follows:

- A. First, if the fuel control hose is attached by using the dry break disconnect remove it. If it is attached permanently proceed with the next step.
- B. The poppets must be closed by rotating the poppet handle in the direction marked closed. During the final portion of handle closing travel, a resistance will be felt as the coupler poppet enters the seal and must displace the liquid trapped within the coupler and unit.
- C. Maintain a moderate steady force in the closed direction to permit the coupler poppet shaft to open the

relief valve in the unit and vent some of the trapped liquid downstream of the unit outer piston seat, permitting the poppets to close.

D. With the poppets closed the seal between the coupler and the adapter is broken, and a poppet leak check may be accomplished, if so desired.

E. Separation is achieved by using one hand to grasp the hose and hold the coupler square to the adapter, relieving hose weight tension on the lugs locking the coupler to the adapter. Depress the collar stop assembly and lift the collar with the other hand. Then lift the coupler off the adapter. The spring-loaded detent pin will extend, locking the collar in the retracted position. With the collar retracted, a physical interference between the collar and the handle prevents accidental opening of the coupler poppet.

F. Following reinstallation of the dust cap, the operational cycle is complete and the unit may be returned with the pickup hose to its normal storage location.

5.0 SAFETY INFORMATION - PERIODIC INSPECTIONS

The equipment described herein is designed primarily for safe, convenient, and reliable operation under normal operating conditions. However, the more exposed parts are subject to damage, and to wear with time that can result in unreliable or unsafe operation if not detected or corrected. Consequently, it is considered mandatory that a brief safety inspection is accomplished periodically. The frequency of this inspection can vary depending upon the utilization; however, under no circumstances should the frequency be less than once a month. A more thorough periodic inspection should be accomplished

at least once a year. Both inspections are discussed in the following paragraphs.

5.1 INTERLOCK

The coupler incorporates an interlock feature that prevents it from being opened unless it is installed onto a hydrant or adapter. The unit may not be removed from the hydrant unless the operating handle has been moved to the closed position. An additional safety system, collar stop assembly, has been provided to prevent the unit from being **blown off** the hydrant in the case where the hydrant valve adapter

poppet fails to close with the coupler disengagement. During the connection cycle, the interlock is automatically disengaged by the proper alignment of the coupler with the hydrant. During the disconnection cycle, it is necessary to manually depress the collar stop assembly to allow the collar to be moved away from the hydrant valve and complete the cycle. Should a major leakage occur after the operating handle has been closed and before unlocking the collar stop, this indicates a failure of the hydrant valve poppet. One should first reopen the coupler poppet and make sure that the hydrant valve pilot has been closed and then close the servicing valve on the hydrant valve before attempting to remove the coupler. If the leakage still is apparent, attempt to re-open the coupler to stop the leakage and then shut down the operation of the system prior to completely disconnecting the coupler to prevent a possible catastrophic spill.

5.2 QUICK DISCONNECT RETENTION METHOD

There are two different styles used to retain the quick disconnect at the outlet of the coupler. Both have some features in common. The female half of the quick disconnect assembly, in both cases, is connected to the male half by means of balls that mate with a groove in the male half and are retained there by a sleeve around the outer diameter of the female half. The sleeve maintains inward pressure on the balls to keep them in the groove of the male half. The retention of the sleeve does differ between the two styles.

The retention on these options is the same as previously used on the 60700-1 and 60600 type couplers. The sleeve itself is maintained in place by a partially circular wire retaining ring. This ring engages coincidental grooves in the quick disconnect housing and the sleeve. The spreading of the retaining ring allows disengagement of the retaining ring from the sleeve groove and, therefore, movement of the sleeve away from the balls. A retainer plate is used to cover the retaining ring to prevent all but intentional spreading. The coupler should never be operated without the installation of this plate. A secondary locking ring is also provided to prevent the sleeve from moving away from the coupler unless it is intentional.

5.3 CARRIAGE ASSEMBLY - OPTION W.

Caution: When utilized, the Carriage Assy incorporates a torsion spring, which can produce potential injury if the unit is not handled properly. Extending and retracting the castors of the unit should be done with care to prevent possible injury.

5.4 MONTHLY PERIODIC SAFETY INSPECTIONS

5.4.1 Accomplish the following at least once each month: (An experienced operator should be able to accomplish these inspections in 30 to 45 seconds.). The parenthetical numbers are the item numbers in the list of materials in the referenced tables.

A. After removing the Dust Cap (1-2) inspect the 16 Locking Lugs (2-33, 2-33A) to determine if any are missing, broken, bent, abnormally worn, etc. Verify that the Detent Pin (2-26) is extended and prevents collar extension. While holding the Collar (2-27) retracted, depress the Detent Pin (2-26) and release it to verify that it returns to the extended position. Examine the Collar (2-27) for excessive wear, cracks, or other damage. Verify that the Collar Stop Assembly (1-24) is in place and not bent.

Reason: Missing, damaged, cracked, and abnormally worn or broken lugs can result in fuel pressure ejecting the coupler off the adapter with the poppet open. A stuck or malfunctioning detent pin can permit collar extension and accidental opening of the coupler poppet with the coupler disengaged from the adapter. The collar stop option, if present, prevents gross adapter poppet leakage from raising the collar and blowing the coupler off the adapter.

B. Visually inspect the closed Poppet (2-15) for signs of abnormal positioning. Visually inspect the molded rubber seal (2-17) for cracks and tears.

Reason: Abnormal poppet retraction or extension indicates a compression or tension failure of portions of the internal linkage that could either result in a mid-position jam or complete separation of the linkage and accidental poppet opening. Damage to the molded seal can result in coupler connected external leakage or coupler disconnected poppet leakage.

C. If the unit incorporates Product Selection (Option C), verify that it is properly installed and that the bolt heads do not extend above the adjacent collar surface.

Reason: Improper product selection installation will, at the very least, result in an unnecessary connection delay, and at the worst, permit connection to the wrong product.

D. Inspect the poppet-operating handle (1-4) for bent, worn, broken, or missing pieces on the round cam-like surface (1-9). Inspect the adjacent surface of the collar (2-27).

Reason: The round portion of the handle locks the collar in the engaged, extended position. Broken, bent, or missing portions of this handle, or of the collar, may permit accidental collar retraction with the poppets open that could result in the coupler being ejected from the adapter.

E. Visually inspect the Nuts (3-3) securing the coupler housing (1-11) to the elbow (1-1) for security of installation and damage.

Reason: If the nuts are found to be loose or not properly tightened leakage of the joint may occur.

F. Visually inspect the female half quick disconnect (5-1) or (5-1A) to verify that the ball retaining sleeve is fully engaged. On options 3 & 4 verify that the ring retainer (6-4 or 7-4) is secured by two lockwired screws so that the two ends of the retainer ring (6-7 or 7-7) extend through the remaining two holes in the ring retainer. Verify that the lock ring is engaged in the safety groove immediately adjacent to the ball-retaining sleeve (6-6 or 7-6).

Reason: See WARNING in paragraph 7.1.

G. Visually inspect the fuel control line connection to the unit's connector for security of installation and damage.

Reason: Pressure tight fuel connection is required for proper function. Unit body depressions or dents may cause leakage, resulting in an improper deadman release shutdown.

5.5 EXTENDED PERIODIC INSPECTIONS - (ANNUAL INSPECTION)

In addition to the safety inspection advocated above, a more extended inspection should be accomplished at least annually.

It will be necessary to provide a container to capture entrapped fuel during the following inspection.

- A. Refer to paragraph 7.1 for method of separating female half quick disconnect (6-1 or 7-1) from the automatic fuel pressure control valve. Capture spilled fuel in a suitable container.
- B. Inspect female half quick disconnect (5-1) or (5-1A). Inspect balls (6-8 or 7-8) for chips, flat spots, or excessive wear. Inspect ball retaining sleeve (6-6 or 7-6) for cracks and wear from the balls. Inspect housing (6-5 or 7-5) on the female half for cracks or thread damage.
- C. Replace male adapter O-ring (6-7) and Teflon Seal (7-9). Inspect ball race Rings (6A-2 or 7A-2) for brinelling (indenting of the material by the Balls (6-8 or 7-8) and other indications of damage. Replace brinelled or damaged ball race Rings (6A-2 or 7A-2). Remove outer ball race Ring Rings (6A-2 or 7A-2) and measure the smallest wire diameter. Replace the ball race ring if the smallest wire diameter is 0.123 inch (3.12 mm) or less. Reinstall an acceptable ball race Ring Rings (6A-2 or 7A-2).
- D. Conduct the Coupler Lower Half inspection detailed in paragraphs 5.6 and 5.7. If the specified Wear Gauge, 61362, is not available then continue with the inspections detailed in paragraphs E and F below as an alternative. The use of the Wear Gauge is preferred and will give more positive results.
- E. Grasp opposite sides of the Collar (2-27) with the fingers while depressing the spring loaded Detent Pin (2-26) with one thumb. The Collar (2-27) will move to the engaged position, away from the Poppet Operating Handle (1-4). Verify that the 16 Lugs (2-33, 2-33A) cannot be depressed back into the collar with the Collar (2-27) extended.
- F. Inspect 16 coupling Lugs (2-33, 2-33A) very closely for wear, cracks or damage. If any Lugs (2-33, 2-33A) are cracked, damaged, missing, or worn locally beyond 0.030 inch (0.76 mm), the unit is unsafe and should be withdrawn from service and completely overhauled. This inspection may be made by comparison with a new Lug (2-33, 2-33A).

Press the tip of one Lug (2-33, 2-33A) inward until stopped by the Collar (2-27). While holding the Lug (2-33, 2-33A) inward, rotate the Collar (2-27) through 360° to determine whether any grooves have been pressed into the Collar (2-27) by the Lugs (2-33, 2-33A) during previous misuse. If such grooves are evident, they will alternately cause the Lug (2-33, 2-33A) to move out and in when it is pressed against the Collar (2-27). If grooves are felt, the coupler is unsafe and should be removed from service and completely overhauled.

Alternately press each Lug (2-33, 2-33A) against the Collar (2-27) to determine which lug protrudes the least distance through the body slot. Then, while holding the Lug (2-33, 2-33A) against the Collar (2-27), use a scale to measure the inward distance the lug tip protrudes from the adjacent body (2-5) inside diameter. If the measured distance is less than 0.15 inch (3.8 mm) the coupler is unsafe and should be removed from service and completely overhauled.

G. Carefully operate the Poppet Operating Handle (1-4) to the open position while capturing trapped fuel in a suitable container. Operation should be smooth and even.

Note: The molded rubber Nose Seal (2-17) which is normally contained either by the Poppet (2-15) or the pit adapter face, may extend with the Poppet (2-15) contingent on the relative friction between the Poppet (2-15) and the Nose Seal (2-17) and that between the same Nose Seal (2-17) and the Quad Ring (2-18) and Housing (2-5). Do not be alarmed if the nose seal does come out of the unit. Use the opportunity to inspect the Wave Washer (2-19) for damage. The Wave Washer (2-19), single piece unit, is designed such that the ends of layers will be forced against the adjoining layers. If installed incorrectly the ends move away from the adjoining layers and into the Nose Seal (2-17) or Body (2-5) causing it to move inward until it tends to jam the mechanism. The Wave Washer (2-19) should be inspected to assure that it is correctly arranged. Refer to Figure B for a graphic representation of the correct arrangement. If it is incorrect it can easily be changed by turning it within itself. The seal Quad Ring (2-18) may also be replaced if it appears scrubbed. Reposition the Wave Washer (2-19) and install the O-ring (2-18) onto the Nose Seal (2-17) prior to closing the Poppet (2-15).

H. Inspect the molded rubber Nose Seal (2-17) for damage, tears, etc. on both the adapter and poppet sealing surfaces. Replace if damaged.

I. Depress the Collar Stop Assy (1-24) and verify that the Collar (2-27) cannot be retracted with the Poppet Operating Handle (1-4) in any position but the full closed position.

J. With the Poppet (2-15) closed and the Collar Stop Assy (1-24) depressed, push the Collar (2-27) to the retracted position while observing that the spring loaded Detent Pin (2-26) extends and locks Collar (2-27).

K. With the Poppet (2-15) closed, precisely measure the distance between outer surface of the molded seal and the adjacent surface of the coupler body at two places 180° apart. If the average of these two measurements exceeds 0.100 inch (2.54 mm), the internal linkages are excessively worn and the coupler should be withdrawn from service and completely overhauled.

NOTE:

 THIS EDGE MUST BE ON TOP OF THE SPRING COIL.

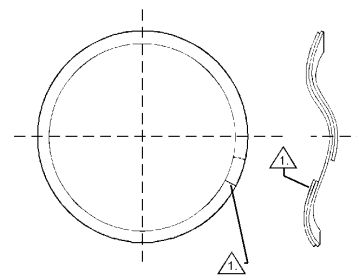

FIGURE B - Wave Washer (2-19)

L. Remove the Elbow Assembly (1-1) from the assembly and apply 60 psig minimum air to fuel control port. The Piston (3-11) should open. Maintain pressure and using a flashlight; carefully inspect O-ring (3-39). Relieve air pressure. Unit piston should close. Using the flashlight, inspect relief valve passage in unit Seal Retainer (3-14) and verify it is clean and not clogged.

M. If the unit contains Option C, Product Selection, inspect for security, effectiveness and

damage. Verify that product selector bolt heads are flush to 0.03 inch (0.76 mm) below the adjacent Collar (2-27) surface.

N. Lubricate unit outlet O-ring (1-12) and Teflon seals (1-11) on Option 2 female half disconnect, O-ring (6A-7) on Option 3 male adapter, or Teflon Seal (7-9) on Option 4 female half disconnect, as appropriate, with petroleum jelly. Reassemble and safety lock the female half quick disconnect, per paragraphs 7.1. F - J.

O. Check the mating flange on the Elbow (1-1) with the Body (2-5) for damage to the studs in the Elbow (1-1) or the wall of the Elbow (1-1). Check the wall between the inner diameter of the coupler upper half Elbow (1-1) and the studs. The diameter should be smooth and continuous with no evidence of bulging or hairline cracks. If the wall is bulged or cracked, the studs retaining holes are already over stressed and the part is no longer safe for use. The coupler Elbow (1-1) will have to be replaced.

5.6 PRIOR TO EACH OVERHAUL OR ON AT LEAST AN ANNUAL BASIS –

The latest edition of API 1584 requires each coupler and hydrant valve manufacturer to have inspection gauges available to help inspect for excessive wear that may be a cause of inadvertent disconnect between the coupler and the hydrant valve.

Model 61362 Coupler Wear Gauge

Eaton's Carter brand has offered this wear gauge for years. When used as instructed, it indicates whether there is excessive wear in the coupler system that requires additional inspection of detail parts.

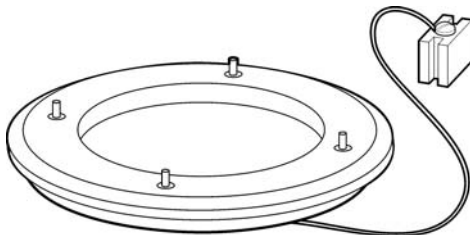

61362 Coupler Wear Gauge

Model 61362 Wear Gauge has been revised to add a second step in inspection of the coupler connection system including a more definitive gauge for checking the wear on the individual lugs. The revision to the 61362 Inspection Gauge entails the addition of the lug inspection attachment shown to the right in the drawing above.

A. **Installation** - Place the Wear Gauge into the inlet of the coupler with the pins of the gauge pointing toward the coupler inlet.

Note: Be sure that the pins do not rest on the coupler Detent Pin (2-26).

Extend the Collar (2-27) to the locked-on position and open the Poppet (2-15). This must be done to simulate a coupler locked onto a hydrant valve.

Note: This operation should be done with a catch basin under the coupler so as not to spill fuel trapped inside the coupler.

B. **Operation** - Once the Wear Gauge is in place, all four (4) gauge pins of the gauge should be above the exposed gauge surface. Slowly rotate the Collar (2-27) while bearing on one side of the Collar

(2-27). Note the position of the gauge pins as the rotation is accomplished. Should any one of the four pins become flush or receded below the gauge surface, the coupler exhibits excessive wear and should not be used again until overhauled. See note below. Pay particular attention to the detailed inspection of the Collar (2-27), Body (2-5), Lugs (2-33, 2-33A) and Lug Rings (2-32) during the following maintenance procedure.

Note: Should only one pin (of the gauge) indicate wear, it is suggested that the gauge be removed and turned approximately one-fourth turn and the inspection be repeated. There may be a local indentation in the surface of the Body (2-5) on which the pin rests causing a false reading.

C. Remove the wear gauge from the coupler and "cheat" it open by depressing the Detent Pin (2-26) to pull the Collar (2-27) to the locked (onto a hydrant) position. This will rotate the locking lugs to the "locked-on" position.

Refer to the figure to the right and check each lug separately by placing the lug part of the gauge onto a lug.

If the gauge sits squarely onto the I.D. of the coupler housing (2-5) with the tip of the lug not touching the bottom of the gauge slot, the lug (2-33, 2-33A) or the actuating Collar (2-27) has excessive wear. Note the lug that needs replacing and move onto inspect all 16 lugs. A lug in good condition will raise the gauge away from the coupler housing (2-5) I.D.

If any of the lugs show wear, replace them all. After replacing lugs recheck each again to determine if the Collar (2-27) could have also been worn.

5.7

Check for excessive wear - Couplers do not last forever and based on their use they should be inspected for excessive wear to prevent an inadvertent "blow-off" from the hydrant valve that can be caused by excess wear. The couplers may not be the only problem.

A. Hydrants may also be worn out. Periodically use the 60554ST1 Wear gauge on all hydrant valves and take necessary action if they are worn. Refer to the service manuals for the procedure on using the gauge. The following check should be made on the couplers depending upon the age but at least once a year (more often when the coupler reaches 5 years or older):

B. Refer to Figure C - Depress the detent pen in the face of the coupler and slide the Collar (2-27) away from the elbow to simulate a coupler ready to be opened. It is not necessary to open the poppet. A catch basin should be used if fuel is still in the coupler.



C. One person should hold the coupler body (elbow if present) while another person pushes (rotates) the Collar (2-27) such that it is angular to the body to take up the tolerances and wear between the parts. This can also be done on a hydrant upper half or similar fixture but do not open the poppet which will remove the capability to rotate the parts relative to each other. Take note of the offset of the body (2-5) with regard to the Collar (2-27). If that offset exceeds 0.090" (2.29 mm) the coupler has too much wear for continued use. This dimension on a new coupler could be approximately 0.050" (1.27mm) due to manufacturing tolerances of all the parts.

D. If the coupler is within the above acceptable limits then use the 61362 Gauge for an additional wear check. This check will indicate wear on individual lugs when the new gauge is used in accordance with the service manual

E. The major culprits for wear should be the lugs (3-33), the body (2-5) or the Collar (2-27) as shown in Figure C. The lugs (3-33), if worn, should be replaced. The body (2-5) and the Collar (2-27), if worn, may be reused separately on another coupler if when

assembled the wear is within the above acceptable limits, otherwise discard them.

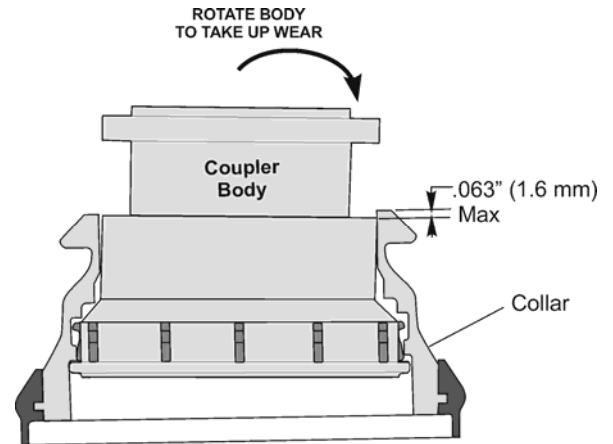

Figure C
Coupler Excess Wear Check

6.0 TROUBLE SHOOTING AND MINOR REPAIR

General trouble shooting analysis and minor repair actions are as follows:

6.1 TROUBLE:

Collar (2-27) will not drop or extend during engagement.

PROBABLE CAUSE:

- A. Coupler improperly positioned.
- B. Product Selection not mated or incorrectly set.
- C. Detent Pin (2-26) is not depressing. If hole in Body (2-5) in which Detent Pin (2-26) is housed is egg shaped it may be difficult to depress.
- D. Collar (2-27) may be out of round.

REMEDY:

- A. Use one hand to relieve hose weight while using the other hand to center and square coupler to adapter.
- B. Rotate Collar (2-27) until Product Selection mates. If adapter flange incorporates a tab, align strip or arrow on Collar (2-27) with tab. Verify that adapter and coupler Product Selection is intended to mate.
- C. If Detent Pin (2-26) can not be depressed due to an out-of-round hole, replace Body (2-5).
- D. If Collar (2-7) is determined to be out of round, replace Collar (2-7).

6.2 TROUBLE:

Poppet Operating Handle (1-4) cannot be moved in open direction.

PROBABLE CAUSE:

Collar (2-27) is not engaged, therefore a physical safety interlock between Poppet Operating Handle (1-4) and Collar (2-27) does not exist.

REMEDY:

Fully engage Collar (2-27). See 6.1 above.

- 6.3 TROUBLE: Poppet Operating Handle (1-4) rotates easily for approximately 45° in the open direction and then a high resistance is felt.

PROBABLE CAUSE:

This is normal if the adapter is pressurized.

REMEDY:

Continue to apply moderate pressure to the Poppet Operating Handle (1-4) in the poppet open direction until the pressure equalizes and the poppet opens easily.

6.4 TROUBLE:

External leak between Coupler Lower Half (1-11) Flange and Pressure Control Elbow Assy (1-1).

PROBABLE CAUSE:

- A. Flange Nuts (3-3) loose.
- B. O-ring (2-10) damaged.
- C. Studs in Elbow (1-1) loose.

REMEDY:

Refer to Figures 1 and 2.

- A. Tighten Nuts (3-3) to 90 ±10 inch pounds (104 ± 12 kg-cm) and recheck for leakage. Note: Special torque wrench kit, WL4680 is available to make it easier to reach less accessible screws and nuts.

- B. Replace O-ring (2-10) as follows:

1. Use suitable container to capture entrapped fuel. Verify coupler is depressurized. Remove six Nuts (3-3) and six Washers (3-2) and Dust Cap (1-2).
2. Carefully separate Pressure Control Elbow Assy (1-1) from Coupler lower half (1-11). Remove and discard O-ring (2-10).
3. Lubricate new O-ring (2-10) and carefully place over pilot on Body (2-5).
4. Carefully assemble Elbow Assy (1-1) to Coupler Lower Half (1-11), reinstalling six

Washers (3-2), Dust Cap (1-2) and six Nuts (3-3). Torque nuts to 90 ± 10 inch pounds (104 ± 12 kg-cm).

5. Pressure check new O-ring installation at 5 and 150-psig fuel pressure, if possible. If not possible, carefully observe for leakage during next use.

C. Studs should be retightened using two nuts on each as jam nuts. If threads retaining studs are damaged then the Elbow (1-1) will have to be replaced.

6.5 TROUBLE:

External leak between disconnect halves.

PROBABLE CAUSE:

Damaged O-ring (5-12), (6A-7) or the Teflon Seal (7-9) in the female half as appropriate.

Remedy:

Remove and replace O-ring (6-7 or 4A-12) or the Teflon Seal (7-9) in the female half as appropriate as follows:

A. Use suitable container to capture entrapped fuel. Refer to paragraph 9.1 for correct method of separating disconnect.

B. With the disconnect separated, remove and discard O-ring (6-7) or (4A-12). Lubricate with petroleum jelly and carefully install new O-ring (6-7) or (4A-12).

C. On options 3 & 4, reconnect, safety and lockwire disconnect assembly per paragraph 7.1.

D. Leak check at 5 and 150 psig fuel pressure, if possible. If not, carefully observe joint during next operation.

6.6 TROUBLE:

Leak at Poppet Operating Handle (1-4).

PROBABLE CAUSE:

O-ring (1-15) damaged, worn or scrubbed.

REMEDY:

A. O-ring (1-15) can be replaced without removing the coupling from the hose.

WARNING:
Assure that the hose is not pressurized.

B. With the coupler held over an adequately sized container, depress the Detent Pin (2-26) and extend the Collar (2-27), operate the Poppet Operating Handle (1-4) in the open direction, opening the Poppet (2-15) to drain the lower half of the coupler. Close the Poppet (2-15) when the lower half of the coupler is drained, depress Collar Stop Assy (1-24) and retract the Collar (2-27) releasing the spring loaded Detent Pin (2-26).

C. Remove Bolt (1-3), lock Washer (1-12), and Washer (1-13). Remove poppet operating Handle (1-4), Key (2-9), and outer shaft seal Bearing (1-14). Use a sharp pointed instrument or pin to remove old O-ring (1-15). Lubricate new O-ring (1-15) with petroleum jelly or equivalent. Use clean, lint-free cloth dipped in clean fuel or solvent to clean the sealing surfaces of the Crank Shaft (2-20) and Body (2-5). Carefully install new,

lubricated O-ring (1-15) using clean, smooth blunt instrument to seat it properly. Inspect O-ring (1-15) to verify that it is not twisted.

D. Reinstall outer shaft seal Bearing (1-14), poppet operating Handle (1-4), Key (2-9), Washer (1-13), lock Washer (1-12), and Bolt (1-3). Torque Bolt (1-3) to 90 ± 10 inch pounds (104 ± 12 Kg-Cm).

E. If possible, connect this coupler to a pressurized adapter and open Poppet (2-15). Observe the Crank Shaft (2-20) for leakage through several poppet opening and closing cycles.

6.7 TROUBLE:

External leakage between unit and adapter or hydrant with unit engaged and Poppet (2-15) open.

PROBABLE CAUSE:

A. Damaged adapter sealing surface.

B. Damaged Nose Seal (2-17).

C. Damaged or worn Quad Ring (2-18).

D. Missing, damaged, broken, or ineffective Wave Washer (2-19).

REMEDY:

A. Replace or repair hydrant adapter.

B. Inspect Nose Seal (2-17) for tears, abrasions, blisters, bond failure, etc. If none are found, proceed to Remedy I. If seal is damaged or otherwise defective, replace Nose Seal (2-17) as follows:

1. Open Poppet (2-15) by depressing Detent Pin (2-26) and sliding Collar (2-17) forward, then rotate Handle (4-1) to the open position. Drain the unit in an appropriate basin or tank.

Remove Screws (2-15B) from Poppet Assembly (2-15) using a torque wrench. The running torque to remove the Screws (2-15B) shall not be less than 6 in.-lb (6.9 kg.-cm.). Remove Poppet (2-15C) and O-ring (2-15D). Discard O-ring (2-15D).

2. Grasp Nose Seal (2-17) with fingers and pull it out of the Body (2-5) bore. Discard Nose Seal (2-17). Remove and discard Quad Ring (2-18). Use opportunity to inspect Wave Washer (2-19) for damage and quantity. Inspect the Wave Washer (2-19) in accordance with Figure B, paragraph 5.5G.

3. Use clean, lint-free cloth soaked in clean solvent or fuel to clean out Body (2-5) bore, and Poppet (2-15).

4. Lubricate new Quad Ring (2-18) with petroleum jelly and assemble it over new Nose Seal (2-17). Ensure that Quad Ring is not twisted.

5. Position Wave Washer (2-19) in Body (2-5) bore.

Carefully insert new Nose Seal (2-17) in Body (2-5) bore, ensuring that new Quad Ring is not pinched.

6. Assemble new O-ring (2-15D) to the Shaft (2-15E) after lightly lubricating it. Install Poppet (2-15C) to the Shaft (2-15E) and Screws (2-15B). Torque the Screws (2-15B) to 10 ± 1 in.-lbs. (11.5 ± 1 kg-cm). If running torque of

Screws (2-15B) is less than 6 in. -lbs. (6.9 kg-cm) replace the Screws (2-15B) with new ones.

7. Close and open Poppet (2-15) several times. Then close Poppet (2-15), depress Collar Stop Assy (1-24) and retract Collar (2-27) to retracted position.

8. If removed, reassemble Coupler Lower Half (1-11) to Pressure Control Elbow Assy (1-1) and conduct coupler functional, proof pressure and leakage tests per paragraphs 12.4 and 12.5.

C. Replace damaged or worn Quad Ring (2-18) using procedure outlined in (B) above for replacing nose seal.

D. Damaged, broken or ineffectual Wave Washer (2-19): Proceed as in (B) above, to inspect Wave Washer (2-19). If the Wave Washer (2-19) is damaged, cracked, or broken, proceed as in remedy (B) (above) to replace damaged Wave Washer (2-19). Do not replace Nose Seal (2-17) unless it is also damaged.

6.8 TROUBLE:

Leakage past Poppet (2-15) seal with coupler disengaged.

PROBABLE CAUSE:

- A. Damaged Poppet (2-15) sealing surface.
- B. Damaged molded rubber on Nose Seal (2-17).

REMEDY:

Isolate problem by reducing pressure in the unit and draining unit, and opening poppet as described in paragraph 6.7B.2. Inspect Poppet (2-15C) sealing surface and Nose Seal (2-17). Replace damaged component or components per paragraph 6.7 remedy B. Disassemble only to the extent necessary to replace either the Poppet (2-15C) or Nose Seal (2-17). Replace Quad Ring (2-18) if Nose Seal (2-17) is replaced

6.9 TROUBLE:

Excess force required during last portion of poppet closing travel.

PROBABLE CAUSE:

- A. Steady force had not been applied to poppet operating Handle (1-4) long enough to permit relief valve to vent trapped fluid downstream, relieving the hydraulic lock.
- B. Pressure trapped downstream of unit.
- C. Relief Valve (3-46 through 3-58) improperly adjusted.
- D. Relief valve passages clogged with foreign matter or unit piston Seat Retainer (3-14) is mis-installed so that relief valve passage is blocked.

REMEDY:

- A. Apply steady moderate force until poppet closes.
- B. Vent trapped pressure.
- C. Maintain steady force on poppet Handle (1-4) and momentarily actuate deadman valve to relieve hydraulic lock and close poppet to permit coupling disengagement. Then, remove the unit from service for

bench correction. Disassemble only to the extent necessary to readjust relief valve or clean clogged passages. Refer to paragraph 11.5.1 for relief valve adjustment, disassembly, and reassembly instructions if necessary. Bench static pressure test all seals that are broken during disassembly.

6.10 TROUBLE:

Unit does not open or opens very slowly (several minutes), when deadman is actuated.

PROBABLE CAUSE:

- A. Coupler poppet has not been opened.
- B. Fuel control hose or passages clogged.
- C. Coupler is closed due to locked in downstream pressure.

REMEDY:

- B. Open coupler poppet.
- B. Loosen hose connection at unit connector and verify that pressure is reaching unit. If it is not, replace or clean out fuel control hose.

Apply 60-psi pressure to fuel control port and determine that piston opens. If not, then overhaul Elbow Assembly (1-1) paying particular attention to the passages between the fuel control port and the piston chamber.
- C. Unit will open when downstream pressure is relieved by initiating flow.

6.11.1 TROUBLE:

Unit opens when deadman valve is actuated, and then abruptly shuts off.

PROBABLE CAUSE:

Downstream system is blocked.

REMEDY:

Open nozzle(s) or other valve blocking flow.

6.12 TROUBLE:

Leakage out the vent port (breather plug) on the top of the coupler.

PROBABLE CAUSE/REMEDY:

O-rings/Seals (3-15), (3-16), (3-38), (3-29), (3-30) or (3-31) need replacing.

6.13 TROUBLE:

Pressure control is not consistent and is not to the desired level.

PROBABLE CAUSE/REMEDY:

The 64035 or 64235 Digital Pressure Control System is responsible for achieving pressure control. Refer to the SU64035 or 64235 Setup Manuals for remedies.

6.14 TROUBLE:

Excessive internal fuel leakage.

PROBABLE CAUSE:

- A. Inlet pressure is above 200 psi and relief valve is relieving.
- B. Fuel Control Pressure in the unit is not fully relieved.

C. Foreign object is holding unit outer piston off seat.

D. Unit seal leakage.

REMEDY:

A. Decrease inlet pressure to less than 175 psi.

B. Completely vent fuel control pressure.

C. Remove unit from hose by disconnecting female half quick disconnect per paragraph 7.1, exercising all specified safety provisions. Actuate deadman to fully open Outer Piston (3-11); use pliers or other gripping tool to remove foreign object; and then release deadman to close unit. Reinstall on hose by connecting female half quick disconnect per paragraph 7.1.

WARNING:
Do not insert fingers into valve while piston is open. Accidental release of deadman could result in finger amputation or other personal injury. Always use needle nose pliers or other grasping tool if practicing this remedy.

D. Remove unit from service and place on test bench to isolate leak path to one of the following by applying 150 psi inlet pressure with the deadman released while observing for leakage through the open unit outlet.

WARNING:
Wear safety glasses or other eye protection while inspecting outlet for leakage.

1. Past Outer Piston Seal (3-7).
2. Past Outer Piston O-ring (3-39).
3. Through relief valve hole in Piston Seal Retainer (3-14).

Then, use the applicable portions of Section 9.0 to disassemble, clean, remove and replace, or polish the defective seal, O-ring, seat, or sealing surface causing the noted leakage. Leakage at point 3 above could result from omission of O-rings (3-52, 3-53) or Spring (3-46) during assembly after overhaul.

E. TROUBLE:

Unit closing rates are too fast.

PROBABLE CAUSE:

Digital Pressure Control not properly setup.

REMEDY:

Refer to SU64035 or SU64235 for proper remedy.

6.16 TROUBLE:

Coupler poppet linkage does not cause relief valve to relieve hydraulic lock and vent trapped fluid downstream of closed unit piston seat.

PROBABLE CAUSE:

Relief Valve (3-46 through 58) is not correctly adjusted.

REMEDIES:

Readjust relief valve per paragraph 11.5.1.J.

6.17 TROUBLE:

Collar (2-27) will not deploy to allow connection to the hydrant valve or adapter.

PROBABLY CAUSE:

The Detent Pin (2-26) may be worn in one location on its angular portion preventing the Ball (2-30) from moving into the hole in the Body (2-5).

REMEDIES:

A short-term remedy is to rotate the Pin (2-26). A more positive remedy is to replace it.

6.18 TROUBLE:

Collar (2-27) will not move to the stowed position or is difficult to move.

PROBABLY CAUSE:

A. The Detent Pin (2-26) is worn on the outer diameter on the spring end of the pin.

B. Coupler is not closed.

REMEDIES:

A. A short-term remedy is to rotate the Pin (2-26). A more positive remedy is to replace it.

B. Close Coupler.

7.0 INSTALLATION

Installation of the Coupler consists of connecting the outlet to the pickup hose and connecting the fuel control hose to the unit connector hose fittings. Proceed as follows:

7.1 PICKUP HOSE CONNECTION

The installation of the coupler to the hose is contingent of the optional outlet arrangement incorporated in the specific unit. The Pressure Control Elbow Assy with the appropriate male half quick disconnect will connect to any of the nine various sized outlet threaded female half quick disconnects with carrying handle. A proper pipe thread lubricant should be used when tightening the female half quick disconnect to the hose thread.

Option 2

On option 2, thumb latches and a spring-loaded sleeve are provided to assure that the locking device is secure. Option X provides extra safety.

A. If Option X, Safety Ring is present gently spread it to move it off the disconnect and leave it on the hose.

B. Depress both Latches (4-8) simultaneously and push the sleeve toward the hose. Pull the female (hose half) away from the coupler to separate.

Options L-R, in conjunction with Options 3 & 4

On options L-R, in conjunction with Options 3 & 4, holes have been provided in the screws used to lock the Retainer (6-4 & 7-4) on the female half in place. It is recommended that these screws be lockwired to further prevent loosening during service.

A. Observe the method of lockwire securing the two screws (6-2 or 7-2) to assure correct reassembly. Break lockwire if present and remove the two screws (6-2 or 7-2). Remove retainer (6-4 or 7-4) on the female half. Note that housing (6-5 or 7-5) on the female half incorporates two lock ring grooves. If the lock ring (6-1 or 7-1) on the female half is installed in the outer groove, away from the ball-retaining sleeve (6-6 or 7-6), proceed to step B. If the lock ring (6-1 or 7-1) on the female half is installed in safety inner groove on the housing (6-5 or 7-5), adjacent to the ball-retaining sleeve (6-6 or 7-6), spread the lock ring (6-1 or 7-1) until it may be moved into full engagement in the second (outer) groove.

B. Grasp outside diameter of the ball retaining sleeve (6-6 or 7-6) with the fingers while using the thumbs to spread the ends of the retainer ring (6-7 or 7-7). Slide ball-retaining sleeve (6-6 or 7-6) back until stopped by the lock ring (6-7 or 7-7) on the female half in the housing (6-5 or 7-5) on the female half groove. This action allows the 24 balls (6-8 or 7-8) to disengage from the mating groove in the appropriate Pressure Control Elbow Assy (1-1). The two parts may now be separated. Note: The O-ring (6-7) utilized, on option 3, to seal the joint between the two halves will provide considerable resistance to separation. The Teflon seal (7-9) used on option 4 will separate easier. Axial force and twisting of the two halves in opposite directions will aid in this operation.

C. When the Female Half Quick Disconnect is disengaged, move ball retainer sleeve (6-6 or 7-6) back to engaged position and temporarily reinstall ring retainer (6-4 or 7-4) on the female half and two screws (6-2 or 6-2) to prevent loss of the parts.

Inspect the hose fitting male threads for dirt and damage. Inspect female threads on Housing (6-5 or 7-5). Clean and repair threads as necessary. Apply anti-seize compound. For Options K, M, N or S (BSPP threads) install a proper sized gasket (not furnished by Eaton) in the proper position. Use the wrench flats on the female housing on the female half to tighten the female half to the hose fitting.

Reconnect safety lock and lock wire the female half quick disconnect to the Pressure Control Elbow Assy (1-1) as appropriate using the following steps:

WARNING:

On options 3 & 4 improper (or omission of) safety locking and lock wiring of the female half quick disconnect can result in accidental separation of the disconnect at high pressures and/or flow rates resulting in a potentially unsafe and undesirable product spill that could result in personal injury.

D. Remove the temporarily installed screws (6-1 or 7-1), and ring retainer (6-4 or 7-4) on the female half. Place the ball retainer sleeve (6-6 or 7-6) in the retracted position as described in B, above.

E. Assure that O-ring (6-7) or Teflon seal (7-9) in the female half as appropriate is lubricated with petroleum jelly.

F. Press forward (away from hose) on ball retainer sleeve (6-6 or 7-6) while spreading retainer ring (6-7 or 7-7) with thumbs while sliding female quick disconnect assembly over outlet of Pressure Control Elbow Assy (1-1) until balls pass into ball race of Pressure Control Elbow Assy (1-1) housing and retaining sleeve (6-6 or 7-6) will suddenly snap forward to the engaged position.

Release the ends of retainer ring (6-7 or 7-7) to allow it to snap into the housing groove.

G. Install ring retainer (6-4 or 7-4) on the female half so that two of its holes capture the ends of the retainer ring (6-7 or 7-7) while the other two holes line up with the threaded holes in sleeve (6-6 or 7-6). Fasten ring retainer (6-4 or 7-4) on the female half with two screws (6-2 or 7-2). Before lockwiring the two screws together, grasp sleeve (6-6 or 7-6) at two places, without touching retainer ring, and attempt to move sleeve (6-6 or 7-6) to the disengaged position.

Caution:

If the sleeve (6-6 or 7-6) on any of the options can be moved toward the disengaged position, or can be partially cocked, the female half quick disconnect is unsafe for use and should be withdrawn from service until the cause is found and corrected.

One probable cause is mishandling that has resulted in permanent deformation of the tips of retainer ring (6-7 or 7-7) which has bent them toward each other. If bent sufficiently, then the installation of the ring retainer (6-6 or 7-6) on the female half will hold retainer ring in the spread position so it is not fully engaged in the housing groove.

H. Lockwire two screws (6-2 or 7-2) to each other with 0.020-inch stainless steel lockwire in a manner that backing out of the screws results in the lockwire being tightened.

J. **Be sure and move the lock ring (6-1 or 7-1) on the female half to safety groove nearest sleeve.** Verify that the lock ring on the female half is fully engaged in safety groove.

WARNING:

On options 3 & 4, omission or loss of ring retainer (6-4 or 7-4) on the female half can result in accidental separation of the quick disconnect under high flow conditions. Under no condition should the disconnect be used without the ring retainer (6-4 or 7-4) on the female half locking the end of the retainer ring and the screws (6-2 or 7-2), securely lockwired.

Options H, K, L, M, N, P, Q & S in conjunction with Option 2

Option 2 provides a tool free disconnect assembly. The female half is connected to the male half by depressing a pair of Levers (4A-8) allowing the sleeve to be withdrawn toward the hose end of the female half. The female half can then be slipped onto the male half. Once in position the sleeve (4A-10) is pushed forward toward the coupler and the levers (4A-8) should automatically latch. This locks the balls (4A-5) into the groove on the male half. The sleeve (4A-10) is held in place by the Levers (4A-8) and a spring (4A-4). If desired a third locking device, Option X Locking Ring can be purchased. If present it has to be removed from the female half to allow the sleeve (4A-10) to be retracted. It should then be replaced in its groove once the disconnect is in place.

7.2

FUEL CONTROL CONNECTION

Connect the fuel control hose to the fitting on the Pressure Control Elbow (1-1). If a hose is permanently connected to the coupler it can either be

connected to the furnished 3/8" NPT fitting or the fitting can be removed and the SAE type fitting and O-ring furnished by Eaton may be removed. Option F provides a means to semi-permanently connect the hose to the coupler with a quick disconnect using Option E female disconnect or similar female disconnect on the hose.

7.3 PRODUCT SELECTOR SET

If unit contains Option C product selection, verify that set is correctly positioned for desired product. If it is not, reposition required Bolt (1-C) and verify that bolt head is flush to 0.03-inch (0.76-mm) below the adjacent Collar (2-27) surface.

F. INSTALLATION INSPECTION

Options 3 & 4 – Verify security of installation, reinstallation and lock wiring of female half quick disconnect retainer screws (6-4 or 7-4), and correct positioning of disconnect. The lock ring (6-1 or 7-1) on the female half. See WARNING in paragraph 7.1.

Option 2 – If Option X is present verify that it is securely in place in the groove in the female half of the disconnect assembly. If it is not present verify that the Levers (4A-8) have returned to their outward position. If not, then check to see if the male and female halves are properly connected.

G. INITIAL INSTALLATION PREPARATION

Following the initial installation of the fuel pressure control coupler, it is necessary to fill the fuel pressure control passages with fuel, and to bleed air from these passages and from the fuel control hose to prevent erratic operation of the fuel pressure control valve (Pressure Control Elbow Assy (1-1). The Plug (3-37)

can be loosened to simplify and shorten the time required for this process.

While the detailed fill and bleed methods may understandably vary according to the detail design of the servicer or dispenser on which the unit is installed, the following general procedure is one practical method of filling and bleeding the Pressure Control Elbow Assy (1-1) following field replacement of the unit. Of course, if the unit is installed on a new servicer that is completely empty, this procedure should not be used since a more rapid method of filling the entire dispenser volume is desirable.

A. Place the coupler face over a hydrant pit valve adapter. Use one hand to relieve hose weight bending forces so that coupler face is centered and square to the adapter, so the Detent Pin (2-26) is depressed and the Collar (2-27) drops.

B. Remove Plug (3-37) and insert a standard 1/4" SAE fitting with an O-ring seal. Connect a short hose and ball valve to the fuel control port to collect any fuel in a bucket. Apply 60-psi fuel pressure to Port "B" Fuel Control Port. This will open the coupler and fill the chamber with fuel. Open the ball valve slightly to bleed the chamber until there is no evidence of air coming from the unit. Remove the pressure to close the coupler with the ball valve still open. Repeat operation several times to be assured that all air is removed.

C. When all air has been bled, replace Plug (3-37), replace the hose from the fuel control port and proceed with normal operation commencing with step 4.1.

8.0 SPECIAL TOOLS

The following special Eaton Carter brand tools are recommended for use during the maintenance of the coupler:

- 61362 Wear Gauge – Inspects completely assembled couplers to indicate wear.
- 60505D or 61526D – 4" API Adapter for use in testing the unit.

- AF42208-1 – Seal polishing run-in tool.
- WL4680 – Screw/bolt torque wrench kit. Includes a torque wrench with 50 – 250 in-lb. capabilities. Contains all special sized sockets to fit into the tight places on the coupler. Can be used on all Eaton Carter brand nozzles and hydrants as well.

9.0 DISASSEMBLY

Refer to various figures later in this document for exploded views or drawings of the unit to assist in disassembly. The numbers mentioned herein are those shown in one of these figures.

9.1 OUTLET CONNECTION TO HOSE

Unless there is a need to replace or repair any parts of the female half of the quick disconnect, it may be left on the hose. Excessive wear of the inside diameter of the sleeve can be a cause of external leakage from the O-ring or seal between the two halves. Removal of the coupler from the female half quick disconnect may be accomplished in the following manner:

A. Options 3 & 4

1. Note the method used to lockwire the two Screws (6-2 or 7-2) to assure correct reassembly. Break the lockwire if present and remove the Screws (6-2 or 7-2). Remove the Retainer Plate (6-4 or 7-4). Note that the

Housing (6-5 or 7-5) incorporates two lock ring grooves. The Lock Ring (6-1 or 7-1) should be installed in the groove closest to the Sleeve (6-6 or 7-6) during operation. Move it to the groove farthest from the Sleeve (6-6 or 7-6).

2. Grasp the outside diameter of the Sleeve (6-6 or 7-6) with the fingers while using the thumbs to spread the ends of the Retaining Ring (6-7 or 7-7). The Sleeve (6-6 or 7-6) may then be moved toward the outlet (hose) end of the unit until stopped by the Lock Ring (6A-1) or (7B-1), unloading the Balls (6-8 or 7-8) that lock the coupler to the quick disconnect. The Female Half Quick Disconnect (1-L-N, P & R) may be removed from the coupler. On couplers with Option 3, considerable force may be required due to the presence of an O-ring seal (6-7) used between the two halves.

B. Option 2 – If present remove Option X Safety Ring (1-X). Depress the two Levers (4A-8)

simultaneously and move the Sleeve (4A-10) away from the coupler. Apply pressure on the Female Half (1-Q, & S) and twist to separate it from the Male Half (4A-17) on the coupler.

9.2 PRODUCT SELECTION SET

If the unit incorporated option C, Product Selection, it is not necessary to remove the Bolts (1-C) from the Collar (2-27) unless there is apparent damage to one of the Bolts (1-C) or the position desired is to be changed. Note that there are six potential positions, numbered 1 through 6. There are two other unmarked slots. The mating unit should have three studs or bolts protruding from it that match the three slots in which there are no bolts. The numbered position that has no bolt is the **set** position.

9.3 PRESSURE CONTROL ELBOW ASSEMBLY

Refer to Figures 1, 3 & 4 to identify the part numbers. Lockwire is used on the Nuts (3-3) only on option D. Nuts (3-3) have holes for lock wire purposes at the option of the customer or furnished when option D is ordered. Remove the Lockwire if present, Nuts (3-3) and Washers (3-2). The Dust Cap (1-2) will be removed with these items also. Removal of the Collar Stop Assembly (1-24) will also be achieved. Set the Collar Stop Assembly (1-31) aside for now. Separate Coupler (1-24) from the Pressure Control Elbow Assy (1-1).

Proceed with the disassembly as follows:

A. Remove the 8 screws, or 8 nuts (4A-20, 6-3 or 7A-3) and washers (on options 2, 3 or 4) retaining the male half of the quick disconnect. Discard O-rings (4A-22), (6-5) or (7A-5) as appropriate.

B. Loosen Lock Nut (3-47) and remove Pressure Relief Adjusting Screw (3-48) and assembled parts, while containing and removing Pressure Relief Valve Spring (3-46).

C. Remove Lock Nut (3-49), Washer (3-50), Seal Retainer (3-51), O-rings (3-52 & 53), Pressure Relief Adjusting Screw (3-48) and Lock Nut (3-47) from Pressure Relief Shaft Assembly (3-54). There is no need to further disassemble Shaft Assembly (3-54) unless replacement of any parts is needed. If needed remove Pin (3-59) to gain access to Washer (3-56), Spring (3-57), Shaft (3-55) and Slide (3-58).

D. Remove the fitting (1-21) (or in case of Options E or F, the disconnect) installed in the fuel control port. Discard the O-ring (1-22). Remove Plug (3-35).

E. It is not necessary to remove the standard transverse Handle (1-23) or further disassemble Option Y Handle (1-Y) unless damaged and they need replacing. In that case remove the attaching Screws (14-3) and Washers (14-2) on the standard handle to replace Grips (14-6 or 15-6), remove Screws (14-4) or (15-5) and Washers (14-2) or (15-5).

F. Rotate Outer Piston (3-11) if necessary, to gain access to the four Screws (3-32). Screw (3-32) is a self-locking type screw that utilizes a nylon insert in the threads to affect the resistance required to provide the locking. They are designed to be reused several times before losing their locking effectively. Using a torque wrench, remove Screw (3-32) from the Housing (3-34), measuring the torque during removal. If the torque is less than 2 in-lbs (0.023-m kg) discard the screw and replace it with a new one during reassembly. Remove and discard O-ring (3-33). Grasp Piston Assembly (3-9) and pull it from the outlet of the Unit.

WARNING

Before proceeding further, beware that the Piston Assembly (3-9) is heavily spring loaded and that a vise or parallel woodworker's clamp will be required to safely disassemble this part of the unit.

G. Either a vise or parallel woodworker's clamp is required to proceed further. Wood blocks should be used to secure the entire assembly such that axial compression is exerted, yet there is accessibility to both of the Nuts (3-12).

CAUTION

Be sure that the assembly is securely held in place and can not slip, allowing the unit to forcibly separate when the first Nut (3-12) is removed. Forcible separation may cause personal injury and will damage some parts beyond repair.

NOTE:

Be careful not to damage the sealing surfaces of the Outer Piston (3-11), Piston Shaft (3-21) or Inner Piston (3-24). Protect these sealing surfaces during and after disassembly. Damage to these surfaces will cause leakage and may cause regulator malfunction.

H. With the assembly securely clamped in place, carefully remove Nut (3-12) from the shaft end opposite the Outer Piston (3-11). Remove Washer (3-10).

I. Slowly open the clamping device, allowing internal spring force to cause the Inner Piston (3-24) to follow the clamp until all spring force is relieved. Then, carefully remove the clamp. Lift Inner Piston (3-24) from the piston Spring (3-20) and remove the Spring (3-20). Remove O-ring (3-23) and Washer (3-22). Remove Nut (3-12) from shaft end near Outer Piston (3-11). Remove Outer Piston (3-11). Remove Shaft (3-21). Remove Screw (3-19B). Spring Guide (3-19) and Retainer (3-14) can then be removed.

Remove Shaft Seal (3-16) and O-ring (3-15) from Retainer (3-14). Discard seal and O-ring after removal.

J. Using two thin 3/8-24 UNF-2B nuts as jam nuts on the Shaft (3-21) at the opposite end to the Outer Piston (3-11), remove Nut (3-12) and Washer (3-10) retaining the Outer Piston (3-11). Remove Outer Piston (3-11) from Shaft (3-21).

K. Remove the six Screws (3-6), Seal Housing (3-4) and O-rings (3-5), (3-8) and Seal (3-7). Discard the o-rings and seal.

L. Remove Screws (3-27) and pull Housing (3-28) from main Housing (elbow) (3-34). Remove and discard Inner Piston Seals (3-31) and O-rings (3-30) from the internal grooves in Housing (3-28), being careful not to damage the surrounding surfaces of Housing (3-28). Remove and discard O-rings (3-29).

9.4 EXCESS FLOW CONTROL DEVICE

A. Remove the two Screws (4-1) and Washers (4-2) from the Excess Flow Device.

- B. Pull the entire assembly from the elbow (1-1). Remove and discard O-rings (4-3), (4-4), (4-5).
- C. Remove the Adjusting Screw (4-6) from the unit and then remove and discard O-ring (4-7). This will remove the spring tension on the internal parts.
- D. Remove Screws (4-8) and Washers (4-9). Pull the Cover (4-11) from the unit and remove and discard O-ring (4-10).
- E. Remove the Spring Retainer (4-12) and Spring (4-13).
- F. Pull the Piston Assembly (4-14) from the unit and then remove and discard Slipper Seal (4-15) and O-ring (4-16) from the Manifold (4-27).
- G. Unscrew the two Flat Head Screws (4-4-17) so that the Latch Stem Slipper Retainer (4-18) can be removed.
- H. Remove and discard Slipper Seal (4-19) and O-ring (4-20) from Manifold (4-27).
- I. Unscrew the Seal Retainer (4-21) and remove it. Discard O-rings (4-22) and (4-23) from the retainer (4-21).
- J. Pull out the Reset Plunger (4-24) and then remove and discard the two O-ring (4-25). Spring (4-26) can then be removed.

9.5 QUICK DISCONNECTS

9.5.1 OPTION "2" MALE ADAPTER WITH VARIOUS FEMALE HALF QD

On option 2, thumb latches and a spring-loaded sleeve are provided to assure that the locking device is secure. Option X provides extra safety.

- A. If Option X, Safety Ring is present gently spread it to move it off the disconnect and leave it on the hose.
- B. Depress both Latches (4-8) simultaneously and push the sleeve toward the hose. Pull the female (hose half) away from the coupler to separate. If option X is utilized, place it in the groove behind the Sleeve Assy (4-6) to keep it from moving forward.
- C. Male Half – Refer to Figure 6 – Loosen and remove Screws (5-20) and Washers (5-21). Discard O-ring (5-22). Remove the Wear Rings (5-19) to inspect for brinelling (indenting of the material by the Balls (5-5) and other indications of damage. Replace brinelled or damaged ball race Rings (5-19).
- D. Remove and discard male adapter O-ring (5-22).

CAUTION:
If the sleeve on any of the options can be moved toward the disengaged position, or can be partially cocked, the female half quick disconnect is unsafe for use and should be withdrawn from service until the cause is found and corrected.

9.5.2 OPTION 3 MALE ADAPTER WITH VARIOUS FEMALE HALF QD

Option 3 is designed to mate with a typically Female QD utilized on Eaton's Carter brand Model 60700-1 Coupler. Refer to Figure 5.

A. Female Half (Options L, M, N, P & R) (ref. Figure 5) – It is assumed that the female half has been removed from the hose and is partially disassembled in accordance with previous instructions. Remove Lock Ring (6-1) from the groove by spreading it and pulling from the housing. Spread the Retaining Ring (6-7) to keep it from catching in either of the other two grooves in the Housing (6-5) as you slide the Sleeve (6-6) off of the Housing (6-5). Take care to catch the Balls (6-8) in a container to prevent losing them as the Sleeve (6-6) releases them.

B. Male Half – Refer to Figure 6 – Loosen and remove Nut (6-3) and Washers (6-4). Discard O-ring (6-5). Remove and discard O-ring (6-7). Remove the Wear Rings (6-2) to inspect for excessive wear in accordance with paragraph 5.5.C.

9.5.3 OPTION "4" MALE HALF ADAPTER QD – with various Female Half QD (Options L, M, N, & P)

This option is designed to mate with a typically Female QD utilized on Eaton's Carter brand Model 60600 or 60600-1 Coupler. Refer to FIGURE 7.

A. Female Half – Refer to Figure 7 – It is assumed that the female half has been removed from the hose and is partially disassembled in accordance with previous instructions. Remove the Lock Ring (7-1) from the Housing (7-5). Spread the Retaining Ring (7-7) to keep it from catching in either of the other two grooves in the Housing (7-5) as you slide the Sleeve (7-6) off of the Housing (7-5). Take care to catch the Balls (7-8) in a container to prevent losing them as the Sleeve (7-6) releases them. Remove Teflon Seal (7-9) from Housing (7-5) and discard.

B. Male Half – Refer to Figure 7A – Loosen and remove Nut (7A-3) and Washers (7A-4). Discard O-ring (7A-5). Remove the Wear Rings (7A-2) to inspect for excessive wear in accordance with paragraph 5.5.C.

9.6 PRE-DISASSEMBLY INSPECTION OF COUPLER LOWER HALF SUBASSEMBLY

NOTE:
It is recommended that the inspection noted in paragraphs 5.6 and 5.7 be done prior to disassembly.

9.7 COUPLER

Refer to Figures 1 and 2 to identify the part numbers. Remove O-ring (2-10) and discard. Remove Bolt (1-3) and Washers (1-4B & C) from Handle Assembly (1-4). Poppet (2-15) should be open for the following actions. Remove Handle Assembly (1-4) and Woodruff Key (2-9).

9.7.1 COLLAR STOP ASSEMBLY (1-31)

Note how Torsion Spring (7-3) is installed to facilitate reassembly. Remove Cotter Pin (7-5). Push out Hinge Pin (7-4), separating Collar Stop (7-1), Torsion Spring (7-3) and Bracket (7-2). Spring should be replaced if it is distorted or weak.

9.7.2 FOLDING HANDLE ASSEMBLY (1-4)

Do not disassemble the Folding Handle Assembly (1-4) unless one or more parts are damaged and require replacement. It is necessary that Spring (1-

7) be replaced whenever the Folding Handle (1-4) is disassembled.

Place the assembly in a small, soft-jawed vice so that the jaws grip the boss of the Handle Cam.

Caution:

Do not over tighten vise as this may collapse or damage handle cam.

Insert large blade screwdriver in clevis end of Pin (1-5). Rotate Pin (1-5) slightly in a counterclockwise direction to release torsion on Cotter Pin (1-6). Remove Cotter Pin (1-6).

Caution:

Maintain a restraining torque on Pin (1-5) with screwdriver to prevent spring's tendency to unwind following Cotter Pin (1-6) removal. Gradually release Spring (1-7) torsion by slowly allowing Pin (1-5) to rotate the inserted screwdriver until the Spring (1-7) torque has been relieved.

Spring (1-7) must be unwound to access Screw (1-8), which must be removed before Pin (1-5), Handle (1-10) and Spring (1-7) can be removed from Handle Cam (1-9).

9.7.3 COUPLER SUBASSEMBLY (1-11)

Disassemble Coupler Subassembly (1-11) as follows:

Remove Cotter Pin (2-11) and Washer (2-12) from Crank Shaft (2-20). Rotate Link (2-16) slightly and disengage Link (2-16) from Crank (2-20). Remove Bearing (2-13). Press Poppet (2-15) and Link (2-16) far enough out of the coupler outlet end to remove Pin (2-14). Then withdraw Poppet (2-15) and Link (2-16) from opposite ends of the coupler.

It is not necessary to disassemble Poppet Assembly (2-15) unless a part of the unit is to be replaced or the unit is undergoing a major overhaul.

If disassembly of the Poppet Assembly (2-15) is required do so by removing the four Screws (2-15B). Remove these Screws (2-15B) using a torque wrench noting the running torque as they are removed. If the running torque is less than 6 in.-lbs. (6.9 kg-cm), discard the Screws (2-15B). Remove and discard O-ring (15D).

Remove Seal (2-17), Quad Ring (2-18) and Wave Washer (2-19).

Discard the Quad Ring (2-18).

Rotate the Crank Shaft (2-20) and press down so it enters cavity cast into Body (2-5), then tilt Crank Shaft (2-20) and remove it along with Bearing Washer (2-21). Remove Bearing Washer (2-21) from Crank Shaft (2-20).

Remove Bearing (2-22). Remove one Shaft Seal Bearing (1-14), O-ring (1-15), second Shaft Seal Bearing (1-14) and Shaft Bearing (2-23). Discard O-ring (1-15).

Depress Detent Pin (2-26) and pull Collar (2-27) with Bumper (2-28) to extended position. Remove Retainer Ring (2-29). Withdraw Collar (2-27) over opposite end of

Body (2-5). Ball Bearing (2-30) will fall out. Locate and secure Ball Bearing (2-30). Do not remove Bumper (2-28) from Collar (2-27) unless it is to be replaced. If Bumper (2-28) requires replacement, use a sharp cutting tool to cut it away from Collar (2-27).

WARNING

Use extreme care to prevent personal injury while cutting Bumper (2-28) from Collar (2-27).

Remove four Lug Rings (2-32) each with four Lugs (2-33, 2-33A) attached from Body (2-5). Remove Lugs (2-33, 2-33A) from Lug Ring (2-32).

Insert a metal rod of 5/32 inch (3.9 mm) or smaller diameter in hole in Detent Pin (2-26) to prevent Detent Pin (2-26) from turning while unscrewing Bolt (2-34).

CAUTION:

Do not use pliers or other gripping tools to hold Detent Pin (2-26). Raised burrs on Detent Pin (2-26) may cause pin to jamb depressed, resulting in an unsafe condition that could result in a fuel spill.

Remove Bolt (2-34) and Washers (3-35 & 36). From opposite end, remove Detent Pin (2-26) and Detent Spring (2-31) from Body (2-5). Disassembly of the Coupler Subassembly (1-11) is completed.

9.8

60532 & 60532C CARRIAGE ASSEMBLIES

Refer to Figure 9.

The Carriage Assy (1-W) should be removed from the unit before any work is performed on it.

CAUTION!

When operating the Carriage Assembly do not place hands onto any part of the unit except the Lever (9-10). Improper operation can result in injury to the hands.

NOTE

The 64804 utilizes the existing hardware to install the Carriage Assembly, no different bolts or nuts are required.

NOTE

Couplers using either options 3 or 4 disconnects must use 60532C Carriage. This unit has integral spacers on the flange to remove interference with the female half of the disconnect.

If an existing Carriage Assembly from either a 60700-1 or a 60600 Type Coupler is to be used on a 64804, contact Eaton for instructions prior to trying to assemble.

To remove Carriage Assembly (1-W) from the unit remove only Nuts (3-3) and Washers (3-2) that remain to the unit. To disassemble the carriage, remove Nuts (9-1), Washers (9-2) and Casters (9-3). Remove one Screw (9-4), Washer (9-5) and Washer (9-6). Set feet of Strut (9-16) into a soft jawed vise and hold securely. Grasp Spring (9-8) with a pair of vise grips, or other suitable tool, to hold it in place. Pull the Shaft (9-7)

from the Strut (9-16). Items (9-9) and (9-10) will then be loose. The other Washers (9-6) will also be loose. There is no need to remove the other Screw (9-4) and

Washer (9-5) from the Shaft (9-7) unless one of the parts is to be disassembled. Remove Cotter (9-14) and Clevis (9-15) to disassemble Latch (9-13).

10.0 INSPECTION AND REPAIR

10.1 GENERAL

Inspect all metal parts for cracks, nicks, gouges, scratches, corrosion, etc. Special attention should be given to the Body (2-5) in the window areas that contain the Lugs (2-33, 2-33A). Weld repair in the area is not recommended due to potential distortion of the Body (2-5) which could cause the Collar (2-27) not to slide freely on the Body (2-5). Inspect all parts for stripped or crossed threads and loose inserts.

Use a new Lug (2-33, 2-33A) as a template. Compare each Lug (2-33, 2-33A) to the new Lug (2-33, 2-33A). Reject all lugs with local wear exceeding 0.030 inch (0.76 mm) by comparison to the new Lug (2-33, 2-33A). Carefully inspect all remaining Lugs (2-33, 2-33A) for cracks or other damage.

Caution:

Lug (2-33, 2-33A) failure can result in the coupler being ejected from the mating adapter. Replace any Lug (2-33, 2-33A) that is questionable.

10.2 COLLAR STOP ASSEMBLY (1-24)

Inspect Torsion Spring (8-3) for distortion. Free ends of Spring (8-3) shall be in proper position and actuate Collar Stop (8-1) without evidence of sticking or binding. Inspect Collar Stop Assembly (1-24) for damage sufficient to prevent proper operation paying particular attention to Bracket (8-2).

H. Detent Pin (2-26) – Inspect diameter of end closest to Spring (2-31), annulus and 25° angle cam surface of pin for excess wear. Replace Detent Pin (2-26) with local wear in excess of 0.005 inch (0.125 mm) deep. Hint – It may be possible to prolong the life of the pin by rotating the pin such that any visible wear is not presented toward the Ball (2-30).

10.3 COUPLER SUBASSEMBLY (1-11)

Precisely measure the following wear surfaces. Discard and replace those parts that fail this inspection:

I. Lug Rings (2-32) – Inspect the four Lug Rings (2-32) for local wear. Replace rings where local wear has reduced local wire diameter below 0.149 inch (3.78 mm).

A. Pin (2-14) – Inspect bearing diameter for indications of galling, raised metal, etc. Replace pin if local wear results in low spots exceeding 0.005 inches (0.12 mm) below adjacent surfaces.

J. Ball Bearing (2-30) – Inspect Ball Bearing (2-30) for local wear or flat spots. Replace if any flat spots are observed.

B. Link (2-16) – Place Link (2-16) on straight edge or surface plate and inspect for flatness. Replace Link (2-16) if bent. Measure longest dimensions of both holes in Link (2-16). Replace if longest dimension of the smaller hole exceeds 0.382 inch (9.70 mm) and larger hole exceeds 0.505 inch (12.83 mm).

K. Wave Washer (2-19) – Carefully inspect the Wave Washer (2-19) for cracks. Replace cracked Wave Washer (2-19). Check part to paragraph 5.5K, Figure B.

C. Dust Cap (1-2) – Inspect for continued serviceability. Replace if required.

L. Collar (2-27) – Inspect the 0.335 inch (9.5 mm) wide shoulder, located on the collar's inside diameter 1.36 inches (35.5 mm) from the collar's connection end, for local depressions in excess of 0.08 inch (2.0 mm) wide and 0.010 inch (0.25 mm) deep. Replace Collar (2-27) if any are found. The inside diameter of the Collar (2-27) that rubs against the outer diameter of the Body (2-5) will also wear. The amount of allowable wear of both parts together is checked by the use of wear gauge Model 61362. This allowable wear will be checked on a post assembly check using the wear gauge.

D. Bearing (2-13) – Measure outside diameter and inside diameter of Bearing (2-13). The outside diameter should not be less than 0.494 inch (12.55 mm) in the smallest dimension. The inside diameter should not be greater than 0.390 inch (9.91 mm) in the largest dimension. Replace Bearing (2-13) if either of these dimensions is exceeded.

M. Body (2-5) – Inspect Body (2-5) for excessive wear, abrasions, gouges, cracks, etc. Pay particular attention to the area around the windows in which the Lugs (2-33, 2-33A) fit. If this area is cracked, replace the Body (2-5). Determine that the two pins shown in Figure 2 are in place. These pins are used to prevent rotation of the Lug Rings (2-32).

E. Crank (2-20) – Measure the diameter of the protrusion on the Crank (2-20) that mates with the Bearing (2-13). The diameter of the protrusion shall not be less than 0.365 inch (9.271 mm). Excessive wear of the protrusion will cause failure of the Bearing (2-13). In addition, wear of the crank will increase the side load on the Poppet (2-15) or Shaft (2-15E) which may result in catastrophic galling of the shaft and the shaft support in Body (2-5).

F. Poppet (2-15C) and Shaft (2-15 E) – Inspect sealing surface for nicks, scratches, or gouges that will cause leakage. Polishing with abrasive cloth, 300 grid or finer may repair minor scratches. Measure Shaft (2-15E) through-hole largest diameter. Replace Shaft (2-15E) if through-hole largest diameter exceeds 0.382 inch (9.70 mm).

Caution:

If the pins are missing, rotation of the Lug Rings (2-32) will cause Lugs (3-33) to drop out and can cause a coupler disconnect.

G. Lugs (2-33, 2-33A) – Measure diameter of hole through all 16 lugs. Reject all lugs with hole dimension greater than 0.163 inch (5.15 mm) in any direction.

The outer diameter of the Body (2-5) that rubs against the Collar (2-27) will also wear. The amount of allowable wear of both parts together is checked by

the use of the wear gauge Model 61362. This allowable wear will be checked on a post assembly check using the Wear Gauge.

N. Folding Handle Assembly (1-4) – Inspect the round surface of the Handle Cam (1-9) and the adjacent surface of the Collar (2-27) that acts as the interlock. If cracked, bent or worn, replace damaged handle or Collar (2-27).

10.4 QUICK DISCONNECT ASSEMBLY – used with Options 3 & 4, in conjunction with Options L, M, N, P & R.

A. Balls (6-8 or 7-8) – Inspect the 24 balls for chips, flat spots, excess wear, etc. Replace as required.

B. Sleeve (6-6 or 7-6) – Inspect inside of Sleeve (6-6 or 7-6) for indications of brinelling or ball indentations at intersection of tapered surface with constant inside diameter at ball lock area as well as for cracks, excessive abrasions, or other damage. Replace if damaged or worn as described above. If carrying handle is worn such that it is no longer serviceable, replace entire Sleeve (6-6). Measure the ball lock area which is the smallest inside diameter of the Sleeve (7-6). Replace sleeve if smallest inside diameter is more than 5.415 inches (108.5 mm).

C. Housing (6-5 or 7-5) – Inspect Housing (6-5 or 7-5) for damage, abrasions, thread damage, cracks, etc. Inspect grooves on the outside of the Housing (7-5) for rounded edges. Replace Housing (6-5 or 7-5) if grooves are excessively worn such that they no longer safely retain rings.

D. Retainer Ring (6-7 or 7-7) – Place Retainer Ring (6-7 or 7-7) over Housing (6-5 or 7-5) so it is fully engaged in its groove (which is the groove closest to the ball bearing holes). Press tips of the Ring (6-7 or 7-7) toward each other, but do not deform them. While pressing the tips, use a 7-inch vernier caliper, or equivalent, to measure the dimension from the outside of the one tip to the outside of the other tip. The dimension must be 3.90 inches (99.1 mm) minimum. If the dimension is less, the Retaining Ring (6-7 or 7-7) should be replaced.

E. Inspect Teflon Seal (7-9), if present (Options 4 only), for obvious damage, replace if needed.

F. On the Male Half (7A-1) for Option 4 (mates 60600 type coupler), check outer diameter that mates Teflon seal (7-9) for damage of any kind that will cause the seal to leak. Replace part (7A-1) if scratches are present that may have caused the joint to leak.

10.6 PRODUCT SELECTION (If included) –
Inspect the Coupler Subassembly (1-11) to assure the correct number of Product Selection Bolts (1-C) are utilized (five) and that they are placed in the correct positions. The outer head of the bolts should be flush to 0.03 inch (0.76 mm) below the adjacent Collar (2-27) surface.

10.7 CARRIAGE ASSY (1-W)
Inspect all parts, for cracks, especially in the Strut (9-16), Casters (9-3) for excessive wear that will make rolling difficult, and the contact surfaces of the Latch (9-13) and Lever (9-10).

Caution:

When operating the Carriage Assembly do not place hands onto any part of the unit except the Lever (9-10). Improper operation can result in injury to the hands.

Using a new Latch (9-13) as a guide, compare the contour of the new one to the one disassembled from the unit. If there is wear in excess of .030 inch (0.76 mm) it should be replaced.

Measure the distance on the Flange (9-9) between the centerline of the hole for the Shaft (9-7) to the surface that makes contact with the Latch (8-13). The dimension shall not exceed 1.04 inch (26.42 mm). The hole in the Flange (9-9) shall not be larger than 0.544 (13.818 mm).

Measure the Clevis Pin (9-15) diameter. It shall not be less than 0.370 inch (9.398 mm) in the area where the Latch (9-13) makes contact.

Measure the hole in the Latch (9-13). It shall not exceed 0.386 inch (9.804 mm).

Measure the diameter of the Shaft (9-7). It shall not be less than 0.485 inch (12.319 mm).

10.8 PRESSURE CONTROL ELBOW ASSEMBLY

Inspect all parts, especially sealing and seat surfaces, for scratches, nicks or gouges that can be causes for leakage or for operation problems. Clean all parts prior to reassembly. Check the Housing (3-34) for excessive external wear that could lead to structural failure of the unit. On all parts except Inner Piston (3-24) and Outer Piston (3-11), use 320 grit paper to smooth and remove sharp edges. The outer diameters of both the Inner Piston (3-24) and the Outer Piston (3-11) can be polished to remove minor scratches by using a very fine emery cloth while the parts are rotated. **Do not** polish local areas of these diameters. By using the Shaft (3-21) as a fixture, both pistons can be installed in a portable drill held in a vise to achieve rotation. **Do not** break through the hard anodize surface of the part. If scratches are too pronounced, the parts should be replaced. Replace any part with damage exceeding 15% of local wall thickness.

Nuts (3-12) are self-locking types and their locking capability should be checked. Tighten them onto the Shaft (3-21) without the use of a wrench. The resistance to installation should make it impossible to install the nut fully onto the Shaft (3-21). If there is no resistance to installation, the Nuts (3-12) should not be reused.

10.9 GENERAL REPAIR

A. Remove corrosion and minor damage from metal parts by polishing with abrasive cloth, 300 grid or finer. Apply chemical film (alodine 1200 or equivalent) to bared aluminum surfaces.

B. Cleaning – Clean all parts with clean solvent or fuel, using soft bristle brush and lint-free cloth. Air dry.

WARNING:

Use solvent or fuel in safe, well ventilated area only.

10.10 REPLACEMENT

A. General – Replace all parts found damaged beyond repair or found excessively worn during inspections above.

B. Recommended Replacements – Eaton recommends that the following parts, if present, be replaced at each overhaul regardless of condition:

Item	Part No.	Description	Used On
1-14	29216	Bearing	Coupler Assy (1-11)
1-15	MS29513-212	O-ring	Coupler Assy (1-11)
1-7	29179	Spring	Coupler Assy (1-11). Replace only if disassembled or broken.
1-22	MS29512-06	Gasket	Pressure Control Assy (1-1)
2-10	MS29513-249	O-ring	Coupler Assy (1-11)
2-11	202010	Cotter Pin	Coupler Assy (1-11)
2-15D	MS29513-037	O-ring	Coupler Assy (1-11)
2-17	28755	Nose Seal	Coupler Assy (1-11)
2-18	209837-347	Quad Ring	Coupler Assy (1-11)
2-22	292213	Bearing	Coupler Assy (1-11)
2-23	203563	Bearing	Coupler Assy (1-11)
3-7	200665	Seal	Pressure Control Assy (1-1)
3-8	MS29513-151	O-ring	Pressure Control Assy (1-1)
3-13	MS29513-008	O-ring	Pressure Control Assy (1-1)
3-15	203565	O-ring	Pressure Control Assy (1-1)
3-16	221595	Seal	Pressure Control Assy (1-1)
3-17	5610-381-50	Washer, Teflon	Pressure Control Assy (1-1)
3-18	5720-158-25	Washer, Bronze	Pressure Control Assy (1-1)
3-23	MS29513-012	O-ring	Pressure Control Assy (1-1)
3-26	MS29513-006	O-ring	Pressure Control Assy (1-1)
3-29	MS29513-134	O-ring	Pressure Control Assy (1-1)
3-30	MS29513-129	O-ring	Pressure Control Assy (1-1)
3-31	200758	Seal	Pressure Control Assy (1-1)
3-36	MS29512-04	Gasket	Pressure Control Assy (1-1)
3-38	MS29513-038	O-ring	Pressure Control Assy (1-1)
3-39	201201-231	O-ring	Pressure Control Assy (1-1)
3-52	M83248/2-008	O-ring	Pressure Control Assy (1-1)
3-53	MS29513-011	O-ring	Pressure Control Assy (1-1)
4-3	MS29513-008	O-ring	Excess Flow Control Device (1-16)
4-4	MS29513-010	O-ring	Excess Flow Control Device (1-16)
4-5	MS29513-011	O-ring	Excess Flow Control Device (1-16)
4-7	MS29513-006	O-ring	Excess Flow Control Device (1-16)
4-10	MS29513-030	O-ring	Excess Flow Control Device (1-16)
4-15	28967	Slipper Seal	Excess Flow Control Device (1-16)
4-16	M25988/3-128	O-ring	Excess Flow Control Device (1-16)
4-19	28956	Slipper Seal	Excess Flow Control Device (1-16)
4-20	MS29513-007	O-ring	Excess Flow Control Device (1-16)
4-22	MS29513-014	O-ring	Excess Flow Control Device (1-16)
4-23	MS29513-012	O-ring	Excess Flow Control Device (1-16)
4-25	221499	O-ring	Excess Flow Control Device (1-16)
5-11	220872	Wear Ring	Option "2" QD (Figure 4A)
5-12	MS29513-341	O-ring	Option "2" QD (Figure 4A)
5-15	MS29513-045	O-ring	Option "2" QD (Figure 4A)
5-22	MS29513-041	O-ring	Option "2" QD (Figure 4A)
6A-5	MS29513-041	O-ring	Option "3" QD (FIGURE 6)
6A-7	201201-348	O-ring	Option "3" QD (FIGURE 6)
7A-5	MS29513-041	O-ring	Option "4" QD (FIGURE 7A)
7-9	220552	Seal	Option "4" QD (FIGURE 7)

11.0 REASSEMBLY

11.1 GENERAL

Assembly is accomplished in essentially the reverse order of disassembly. The following paragraphs cover assembly of the major components, followed by final assembly of the complete Unit.

11.2 COLLAR STOP ASSEMBLY (1-24)

A. Insert Pin (8-4) through Bracket (8-2), Collar Stop (8-1) and Torsion Spring (8-3). Position free ends of the Torsion Spring (8-3) as shown in FIGURE 8.

- B. Install Cotter Pin (8-5).
- C. Check that the Collar Stop (8-1) moves under pressure of the Torsion Spring (8-3) without sticking or binding.

11.3 FOLDING HANDLE ASSEMBLY (1-4)

Replace Spring (1-7) each time the handle is disassembled. Assemble the Handle (1-4) as follows:

- A. Place the Cam (1-9) in small, soft-jawed vise.

Caution:

Do not over tighten vise and collapse or damage handle Cam (1-9).

- B. Place Spring (1-7) in the clevis of Handle (1-10), with the "leg" end of the spring extended over the top of the handle. Position those two items in the clevis of Handle Cam (1-9). Note the orientation of the flat and slotted end on the Pin (1-5) in Figure 1 to assure correct reassembly. While holding the items (1-7), (1-10) and (1-9) in place, insert Pin (1-5) through holes in Handle Cam (1-9), Handle (1-10) and Spring (1-7).

- C. Fasten Spring (1-7) to Pin (1-5) with pan head Screw (1-8).

- D. Insert large blade screwdriver in clevis end of Pin (1-5) and carefully wind Spring (1-7) in a counterclockwise direction.

- E. When Spring (1-7) is wound, insert Cotter Pin (1-6) to lock Pin (1-5). Operate Handle Assembly (1-4) to fully unfolded position while inspecting the following:

- (1) Clearance between Spring (1-7) and adjacent face of Handle Cam (1-9) should occur throughout travel.
- (2) Clevis ends of Handle (1-10) should bottom on face of Handle Cam (1-9) with Handle Assembly (1-4) in extreme extended condition.

11.4 COUPLER SUBASSEMBLY (1-5)

Replace all parts found defective in the inspections noted above with new or serviceable parts. Replace all parts specified in paragraph 10.10 with new parts. Lightly lubricate all O-rings and threaded parts with petroleum jelly (Vaseline or equivalent).

- A. If a new Bumper (2-28) is being utilized it is suggested that the Bumper (2-28) be heated to 150° - 160° (32° - 71° C) to soften it to make assembly to the Collar (2-27) easier. This can be accomplished in either an oven or in hot water, however, use caution.

Caution:

Do not overheat Bumper (2-28) or it will melt!

- B. Assemble four (4) Lugs (2-33, 2-33A) to each of four (4) Lug Rings (2-32). Assemble the four Lug Rings (2-32) with Lugs (2-33, 2-33A) installed in groove in Body (2-5) so Lugs (2-33, 2-33A) mate with slots in Body (2-5). The end of one Lug Ring (2-32) should be positioned against the spiral pin pressed into Body (2-5) (See Detail on Figure 2). This pin is there to prevent the Lug Rings (2-32) from gradually rotating around during use and allowing the Lugs (2-33, 2-33A) to become dislodged.

- C. Slide Collar (2-27) (with Bumper (2-28) attached) over Body (2-5) from the outlet end, capturing Lug Rings (2-32) and Lugs (2-33, 2-33A). Install large Retaining Ring (2-29) into groove in Collar (2-27).

- D. Lay unit thus far assembled on its side with Detent Pin (2-26) hole in bottom location. Slide Collar (2-27) all the way forward against the Retaining Ring (2-29). Insert Ball Bearing (2-30) into Detent Pin (2-26) hole, making certain that it drops into the hole in the Body (2-5). Slide Collar (2-27) all the way back. Assemble Detent Spring (2-31) to Detent Pin (2-26). Place hardened rod of 5/32 inch (3.9 mm) or smaller diameter through hole at forward end of Detent Pin (2-26) and insert Detent Pin (2-26) and Spring (2-31) in hole in Body (2-5). Depress Detent Pin (2-26) as far as possible and while holding Detent Pin (2-26) depressed, slide Collar (2-27) all the way forward. Holding the hardened rod through the Detent Pin (2-26) to prevent turning, assemble the Detent Pin (2-26) to the Body (2-5) by installing Washers (2-35 & 36) and Bolt (2-34). Washer (2-35), the one with the smallest outside diameter, should be adjacent to the head of the Bolt (2-34). Remove hardened rod after Bolt (2-34) is tightened.

- E. Install Bearing (2-22) into crank shaft bore from inside of Body (2-5). Install Shaft Bearing (2-23) into crank shaft bore from outside of Body (2-5). Place Bearing Washer (2-21) over Crank Shaft (2-20) and insert Crank Shaft (2-20) through bearings (2-22 & 2-23).

- F. Assemble one shaft seal Bearing (1-14), O-ring (1-15) and second shaft seal Bearing (1-14) over Crank Shaft (2-20) from the outside and press these parts into the Body (2-5), exerting care that the O-ring (1-15) is not pinched.

- G. Position Wave Washer (2-19) into Body (2-5) bore. Assemble Quad Ring (2-18) over Seal (2-17) and press into Body (2-5) bore, capturing Wave Washer (2-19) and being careful that Quad Ring (2-18) is not pinched.

- H. If Poppet (2-15) was disassembled, reassemble at this time. Install O-ring (2-15D) into the groove in Shaft (2-15E). Assemble Poppet (2-15C) onto part and retain with the four Screws (2-15B). Torque Screws to 10 ± 1 in.-lbs. (138 kg-cm) noting the running torque before tightening. If the running torque is under 6 in.-lbs. (6.9 kg.-cm.) replace Screws (2-15B) with new ones.

- I. Insert Link (2-16) into Body (2-5) bore so Link (2-16) bump is in the bore's longest slot. Secure Poppet (2-15) to Link (2-16) with Pin (2-14) and press back into bore so Pin (2-14) is captured.

- J. Slightly turn and work the largest hole in the Link (2-16) over lug of Crank Shaft (2-20). Place Bearing (2-13) through Link (2-16) and onto lug of Crank Shaft (2-20). Position Washer (2-12) over Bearing (2-13). Fasten Link (2-16) to Crank Shaft (2-20) with Cotter Pin (2-11).

Note:

The use of a standard headed cotter pin in lieu of the correct part number specified will present a problem when the Coupler Subassembly (1-5) is utilized as a part of Pressure Control Coupler 64804.

- K. Install Woodruff Key (2-9) and Handle (1-4) onto Crank Shaft (2-20). Fasten Handle (1-4) with Washer (1-13), Lock Washer (1-12) and Bolt (1-3). Torque Bolt (1-3) to 90 ± 10 inch pounds (104 ± 12 kg-cm).

L. A post-assembly check using the Wear Gauge, 61362, is necessary to determine if the collective wear between the Collar (2-27) and Body (2-5) is less than allowable. Repeat the gauge check described in paragraphs 5.6 and 5.7. It will be necessary to install the Woodruff Key (2-9) and the Handle Assembly (1-4) loosely to actuate the unit to the open position.

If the unit fails the gauge check, it will be necessary to disassemble the unit sufficiently to replace the Collar (2-27). If after the Collar (2-27) has been replaced and the unit still fails the gauge check, it will be necessary to replace the Body (2-5).

11.5 PRESSURE CONTROL ELBOW ASSEMBLY (1-1)

11.5.1 Assembly

Replace all parts found defective in the inspection of paragraph 10.8. Replace all parts specified in paragraph 10.10 with new parts. Lightly lubricate all O-rings and threaded parts with petroleum jelly (Vaseline or equivalent). Refer to Figure 3 and proceed as follows:

A. O-rings (3-31) should be placed into the grooves in the Housing (3-28). The Inner Piston Seals (3-31) will be installed with the seal "legs" pointing in opposite directions as noted in FIGURE 12. Note that this may be contrary to previous instructions on this or other similar product but it has been found that although more difficult to install the effect is a better seal. The "flange leg" of the Seal (3-31) must be inserted fully into the Housing (3-28) groove. Smooth the combination of the Seal (3-31) and O-ring (3-30) with a finger to assure that they are installed completely into the groove.

Install O-Rings (3-29) onto Seal Housing (3-28). Insert Seal Housing (3-28) into Housing (3-34). Secure Seal Housing (3-28) with Screws (3-27).

B. It is recommended that seal "run-in" tool, AF42208-1 shown FIGURE 16, is used to condition the Seals (3-31) after installation. The tool can be procured through your Eaton Carter brand distributor. The tool can be used with a hand drill to accomplish the run-in task as follows:

(1). With the run-in tool attached to a hand drill, carefully insert the tool into the first Inner Piston Seal (3-31) and using a low speed, push the tool into the unit until the piston passes through the second Inner Piston Seal (3-31). The tool should be kept such that the piston portion of the tool makes contact only with the Seals (3-31) in the Housing (3-34) and does not make metal to metal contact.

(2). Carefully move the tool axially over a stroke of about 0.50 inch (12.7 mm) in and out maintaining contact with both Seals (3-31) for about one minute. The speed of the drill should be maintained at a low to medium RPM.

(3). Remove the tool.

C. Place O-rings (3-26) onto Tube (3-25) and lubricate thoroughly. Insert one end of this assembly into Housing (3-34) until seated.

D. Install O-ring (3-5) into groove on Seal Housing (3-4). Install Seal (3-7) with shoulder of flanged end into groove in Seal Housing (3-4) and O-ring (3-8) between the thin lip of Seal (3-7) and the Seal Housing (3-4).

E. Secure Seal Housing (3-4) into main Housing (3-34) with Screws (3-6).

F. Place Outer Piston (3-11) onto the appropriate end of Shaft (3-21). Hold loosely in place with Washer (3-10) and Nut (3-12). Use two thin 3/8-24-UNF-2B nuts as jam nuts at opposite end of Shaft (3-21) while torquing Nut (3-12) to 195 – 205 inch pounds (225 – 236 kg-cm). Remove the jam nuts.

G. Install O-ring (3-15) and piston shaft Seal (3-16) into the bore in the Retainer (3-14) with the Seal (3-16) shoulder towards the inside of the Retainer (3-14). Slide seal Retainer (3-14) onto the long end of Shaft (3-21). Reinstall the six Screws (19A) to retain the seal. Slide spring Guide (3-19) onto piston Shaft (3-21) with the shoulder of the Guide (3-19) toward the shaft's Outer Piston (3-11) end. Slide the Spring (3-20) over Guide (3-19). Place O-ring (3-23) into groove in the inside of the Inner Piston (3-24). Use sufficient petrolatum to hold the O-ring (3-23) in place during the final assembly. Place the Washer (3-22) on the free end of the Shaft (3-21). Insert bronze Washers (3-20A) into Small Piston (3-24). Place Piston (3-24) over end of Spring (3-20). Use a parallel bar wood worker's clamp to compress the assembly and hold it compressed.

CAUTION:

Be very careful to properly center the slots in the clamp tips and to adjust the two clamp screws evenly so the bars remain essentially parallel while compressing the spring. The piston Spring (3-20) force is between 50 and 55 lbs. when the Shaft (3-21) has entered Inner Piston (3-24) and the Inner Piston (3-24) is bottomed on Washer (3-22).

Install second Washer (3-10). Install second self locking Nut (3-12) and torque to 195 – 205 inch pounds (225 – 236 kg-cm) while holding the other self locking Nut (3-12) with a wrench.

H. Remove the assembly from the clamp. Place O-rings (3-33) onto Screws (3-12).

I. Grasp this assembly by Outer Piston (3-11) struts and carefully insert into Housing (3-34) through the outlet until Outer Piston (3-11) has entered outer piston Seal (3-7) and the piston seat Retainer (3-14) has begun to enter the Housing (3-34) pilot diameter.

NOTE:

Inspect Retainer (3-14) to determine the location of the Connector Tube (3-25) which is the relief valve hole. Rotate the Retainer (3-14), if necessary, so that the Relief Valve hole lines up with the Tube (3-25), which is in the quadrant toward the Housing (3-34) inlet. Once aligned properly continue to press entry of the Retainer (3-14) to seat the O-ring (3-26) on the tube (3-25).

J. Tighten four Screws (3-32) with the four O-rings (3-33) securing Retainer (3-14) to Housing (3-34). Torque to 19 ± 2 inch lbs. (21.9 + 2 kg-cm).

K. Place Gasket (3-36) onto Plug (3-35) and install Plug (3-35).

L. If disassembled, place Spring (3-57) over Spring Slide (3-58). Compress Spring (3-57) with Washer (3-56) until slot in Slide (3-58) is visible above the Washer (3-56). Insert Shaft (3-55) into center hole of assembled parts until the hole in the Shaft (3-55) can be aligned with the slot in Slide (3-58). Insert Pin (3-59) through Slide (3-58) and Shaft (3-55) and release the

Spring (3-57) to arrive at Shaft Assy (3-54). Assemble locking Nut (3-47) and O-ring (3-53) to pressure relief adjusting Screw (3-48). Slide Screw (3-48) over pressure relief Shaft Assembly (3-54). Assemble O-ring (3-52) to seal Retainer (3-51) and slide seal Retainer (3-51) over Shaft Assembly (3-54) until it bottoms on the shaft shoulder. Hold the pressure relief Shaft Assembly (3-54) in one hand and install Washer (3-50) and self-locking Nut (3-49).

M. Place Spring (3-46) over pilot of seal Retainer (3-51) and insert in the hole in the Housing (3-34) inlet. With the locking Nut (3-47) loose, tighten pressure relief adjusting Screw (3-48). Adjust the screw until the sum of a depth micrometer measurement from the head of the Shaft Assembly (3-54) to a parallel bar placed across the Housing (3-34) inlet plus the parallel bar thickness is 1.725 – 1.755 inches (43.8 – 44.6 mm). Then tighten locking Nut (3-47) to 230 – 250 inch pounds (265 – 288 kg-cm).

Example: If parallel bar is measured and found to be exactly 0.500 inch (12.7 mm), then depth micrometer reading should be 1.225 – 1.255 inch (31.1 – 31.9 mm) when relief valve adjustment is within the required limits.

11.5.2 Preliminary Functional Test

True proof pressure, functional and leakage tests are conducted in conjunction with test of the complete coupler, paragraph 12.0. It is well to conduct several tests at this stage of assembly however, before additional assembly labor is expended.

A. Hold the assembly in the hands and place the end of the pressure Relief Shaft Assembly (3-54) against a flat, sturdy surface. Press with enough force to compress the relief valve spring (opening the relief valve) and release (allowing the relief valve to close) several times. Then recheck the relief valve adjustment measurement as described in step P of paragraph 11.5.1.M. The relief valve adjustment should not change and the relief valve should not stick open.

B. Apply and relieve 60 psig air pressure to the fuel port several times. The Outer Piston (3-11) should open fully with each pressure application and fully close as pressure is relieved. There should be no indication of stickiness or hang-up in either direction.

11.6 EXCESS FLOW CONTROL DEVICE –

Reassemble in reverse order of disassembly:

A. Reinstall Spring (4-26). Replace two O-rings (4-25). Insert Reset Plunger (4-24) into Manifold.

B. Replace O-ring (4-22) and (4-23). Screw Seal Retainer (4-21) into Manifold.

C. Replace O-ring (4-20) and Slipper Seal (4-19) in Manifold.

D. Attach Latch Stem Retainer (4-18) to manifold using two Flat Head Screws (4-17).

E. Replace O-ring (4-16) and Slipper Seal (4-15) in Manifold. Reinstall Piston Assembly (4-14).

F. Install Spring (4-13) and Spring Retainer (4-12).

G. Install O-ring (4-10) and replace Cover (4-11). Reinstall Screws (4-8) and Washers (4-9).

H. Install O-ring (4-7) and Adjusting Screw (4-6).

I. Replace O-Rings (4-3), (4-4) and (4-5) then align assembly with attachment holes in elbow.

J. Install Washers (4-2) and reattach to the pressure control elbow using Screws (4-1).

11.7 FEMALE HALF QUICK DISCONNECT (1-L, M, N, P & R)

Replace all parts found defective in the inspection procedures above.

A. Assemble the Retainer Ring (6-7) or (7-7) into Sleeve (6-6 or 7-6). Spread ends of the Retainer Ring (6-7 or 7-7) and slide both parts over Housing (6-5 or 7-5). Temporarily allow Retainer Ring (6-7 or 7-7) to seat in the Housing (6-5 or 7-5) groove nearest the pipe threaded end.

B. Set Housing (6-5 or 7-5) on end in a shallow container with the disconnect end up. Use a cotton-type swab to place a small amount of petroleum jelly on the bottom of each of the 24 holes in the Housing (6-5) or (7-5).

C. Carefully insert 24 Balls (6-8 or 7-8) into the holes in the Housing (6-5 or 7-5). The petroleum jelly should hold the balls in place while the ends of the Retainer Ring (6-7 or 7-7) are spread and the Sleeve (6-6 or 7-6) is moved to the engaged position, capturing the Balls (6-8 or 7-8).

D. Spread Lock Ring (6-1 or 7-1) and assemble into groove closest to threaded end on Housing (6-5 or 6-5).

E. On Option 4 lightly coat Seal (6-9) with petroleum jelly and install into groove in Housing (6-5) being sure that the open end of the "U" shaped part is pointing inward toward the threaded inlet of the Housing (7-5).

F. Keep Retainer (6-4 or 7-4) and Screws (6-2 or 7-2) handy for final assembly as noted later.

11.8 MALE HALF QUICK DISCONNECTS OPTIONS 2-4

Replace all parts found defective in the inspection procedures above.

11.8.1 Option "3" – See FIGURE 6

Replace, if removed, Wire Race (6-2) in the grooves in the Adapter (6-1). It is recommended that the split in the rings not line up when final assembly is completed. Replace O-ring (6-5) onto the shoulder end of the Adapter (6-1) and O-ring (6-7) onto Adapter (6-1). It is now ready for final assembly covered later in this manual.

11.8.2 Option "4" – See FIGURE 7A

Replace, if removed, Wire Race (7A-2) in the grooves in the Adapter (7A-1). It is recommended that the split in the rings not line up when final assembly is completed. Place O-ring (7A-5) onto shoulder of Adapter (7A-1). It is ready for final assembly.

11.9 CARRIAGE ASSY (1-W)

Place the feet of the Strut (9-16) in a soft jawed vise to hold it firmly with the feet flat on the work bench. Install Latch (9-13), Clevis Pin (9-15), Washers (9-12) and Cotter Pin (9-14) into Strut (9-16). Install one Screw (9-4) and Washer (9-5) onto Shaft (9-7). Place two Washers (9-6) onto Shaft (9-7) and then place Shaft (9-7) through one hole of the Flange (9-9) and Lever (9-10). Place another Washer (9-6) between the Lever (9-10) and Strut (9-16). Place this sub-assembly into position with the Strut (9-16)

and the Spring (9-8). The straight tang of the Spring (9-8) is to be placed in the hole in the Strut (9-16).

CAUTION!

Be very careful during the next phase of the assembly. The Spring (9-8) is very strongly loaded and could cause injury if not controlled properly.

Grasp the Spring (9-8) with a pair of battery pliers (channel locks) with the straight tang toward the left. Using a pair of vise grips in the right hand grasp the spring and rotate the spring until the bent tang is approximately into position under the Flange (9-9). Holding the Spring (9-8) with the vise grips, push the Shaft (9-7) through the Spring (9-8) to engage the other hole of the Strut (9-16) and on through the other parts. Note that one Washer (9-6) should be placed between the Strut (9-16) and Lever (9-10) and between the Lever (9-10). Install two Washers (9-6) onto Shaft (9-7). Fasten in place with the other Screw (9-4) and Washer (9-5).

Install Spring (9-11) and Washer (9-12) into recess in Strut (9-16).

FINAL CAUTION!

If Carriage Assy (1-W) is latched when it is not attached to the unit, unlatching may cause serious injury. Be very careful in unlatching the Carriage Assy (1-W) in this position.

11.10 FINAL ASSEMBLY

Verify that the Coupler Subassembly (1-11), the Female Half Quick Disconnect (1-H thru S), Elbow Assembly (1-1) and the Collar Stop Assembly (1-24) have been overhauled and reassembled.

A. Assemble O-ring (2-10) onto the outlet of the Coupler (1-11).

B. Assemble Pressure Control Elbow Assembly (1-1) to Coupler Assembly (1-11) while being careful that the O-ring (2-10) is not pinched. Fasten, along with Collar Stop Assembly (1-24), using six Nuts (3-3), Washers (3-2) and tab of Dust Cap (1-2) beneath one Nut (3-3). Place Collar Stop Assembly (1-24) under two Nuts (3-3) as shown in FIGURE 10. Lockwire Nuts (3-3) if desired using Lockwire (1-D).

C. Install the Female Half Quick Disconnect (1-H thru S) to the Male Half (4A-18). Once in place, assemble the Retainer (6-4 or 7-4) (options 3 & 4 only) in place with two Screws (6-3 or 7-3). For Options M or N (BSPP threads) install a proper sized gasket (not furnished by Eaton) in the proper position. Lockwire the screws to retain them. Use the wrench flats on the Female Half Housing (4A-5, 6-5 or 7-5) to tighten the unit to the hose.

D. If the Carriage Assy (1-W) is utilized it is reinstalled in accordance with FIGURE 11 using the existing hardware Nuts (3-2) and Washers (3-3). No installation kits are required.

Nuts (3-3) should be torqued to 90 ± 10 in.-lbs. (104 ± 12 kg.-cm.).

12.0 TESTING

12.1 TEST EQUIPMENT

The following test equipment is required:

- Inlet test adapter conforming to API Bulletin 1584 with pressure equalization valve such as Eaton's Carter brand Model 60505D or 61526D.
- Outlet test adapter to mate pipe threads in outlet.
- 0-300 psig fuel or test solvent pressure source.
- 0-125 psig air pressure source.
- Shutoff valves, regulators, pressure gauges, and other miscellaneous test equipment.

12.2 TEST CONDITIONS

Test media shall be JP-4, Jet A or odorless kerosene, commercial solvent 140.

12.3 FUNCTIONAL TEST

A. With the Collar (2-27) retracted (Unit not attached to an adapter and closed), verify that the opening Handle (1-4) cannot be rotated to the open position.

B. Depress and release the Detent Pin (2-26) several times to verify that the pin promptly extends and locks the Collar (2-27) each time it is released. Rotate the Detent Pin (2-26) in 90° increments and repeat this operation at each position to verify that there is no position at which the Detent Pin (2-26) hangs retracted.

C. Place the Coupler squarely over an unpressurized, vented Model 60505D or 61526D

Adapter so the face of the adapter depresses the Detent Pin (2-26). The Collar (2-27) should drop freely in a positive manner into the engaged position with no hesitation, sticking or binding. With the Collar (2-27) extended, it should be impossible to separate the Unit from the test adapter. Retract the Collar (2-27), depressing the Collar Lock Assembly (1-24) at the same time, and lift the Unit off of the adapter. The Detent Pin (2-26) should extend and prevent extension of the Collar (2-27).

D. Repeat C several times. Then, engage the Unit to the adapter and open and close the Poppet (2-15) by rotating the operating Handle (2-1 or 1-4), while verifying that it is not possible to retract the Collar (2-27) with the Handle (2-1 or 1-4) in any position but the fully closed position. The Collar Stop Assembly (1-24) should automatically engage the Collar (2-27) each time the Collar (2-27) becomes extended preventing the retraction of the Collar (2-27) until it is manually depressed.

E. Repeat D several times. Then, retract the Collar (2-27) and separate the Unit from the adapter. Verify that the Detent Pin (2-26) has extended and locked the Collar (2-27) in the retracted position. Verify that the Poppet (2-15) can not be opened with the Collar (2-27) retracted.

12.4 PROOF AND LEAKAGE TEST – DETACHED

Caution:

Wear safety glasses or other eye protection during any test to prevent possible eye injury from test liquid exposure.

With the Unit not attached to an adapter, apply 5 psig fluid pressure to the outlet of the Unit and 60 psig fuel pressure to the fuel control hose connection and maintain for one minute. Observe the Unit for external and or seal leakage. Then relieve the applied pressures.

There shall be no indication of external leakage through any joints or through the nose seal during the test.

12.5 PROOF AND LEAKAGE TEST – ENGAGED

A. Connect the **outlet and inlet** to an available fluid pressure source of 0-300 psig. Means to allow bleeding of the outlet should be provided (include a tee in the outlet with a bleed valve or similar means). The test adapter shall have a manually controlled shutoff valve attached to its inlet. Connect a 0-125 psig fuel pressure source to the Unit's fuel control port connection.

B. Open the Unit's Poppet (2-15) using Handle (1-4).

C. Apply 60 psig fuel pressure to the fuel control port connection.

D. Fill the test Unit and adapter with liquid while bleeding all air through the valve at the adapter inlet and the unit outlet. (Rotate the test setup so the adapter and its valve are at the high point while bleeding air.) The pressure sense port must also be filled with test fluid and bled of all trapped air by opening the bleed screw on the top of the elbow. Once bleeding has been completed retighten the screw.

E. Simultaneously increase the test fluid pressure to 300-psig to the sense port, inlet and outlet and maintain for one minute while inspecting the Unit for indications of external leakage.

F. Reduce the test pressure to 5 psig and repeat step E.

G. There shall be no indication of external leakage, permanent deformation or set during or after the above test.

H. Reduce the test pressures to 0 psi. Close the Poppet (2-15) and disengage the Unit from the test adapter.

12.6 INTERNAL LEAKAGE AND FUNCTIONAL TEST

A. Connect the test fluid pressure source to the test adapter inlet. Connect the test Unit to the adapter and open the Poppet (2-15). Remove the Unit's outlet test adapter and place the Unit such that its outlet is in an upward position. Connect the 0-125 psig air source to the Unit's fuel control port connection through a three-way valve.

B. Squeeze and release the fuel pressure valve several times, applying and venting 60 psig pressure,

while observing the movement of the Outer Piston (3-11). The Outer Piston (3-11) shall fully open with each application of pressure and fully close each time the pressure is vented.

C. With the pressure applied, fill the test Unit with test fluid to a level above the Outer Piston Seal (3-7) and release the pressure to close the Outer Piston (3-11). Drain the liquid from the Unit's outlet and increase the internal liquid pressure to 5 psig. Rotate the Unit such that any leakage from the unit can be collected in a beaker or other suitable measuring device and measure liquid leakage at the outlet for one minute. On a factory new Unit the leakage allowable from the Unit is 10 cc/min. An overhauled unit may have a leakage rate of up to 30 cc/min.

12.7 RELIEF VALVE FUNCTION

A. Using the same setup as above, fuel pressure relieved, test Unit filled and bled, place a shop rag or equivalent over the outlet to restrain relief valve flow.

B. Apply 150-psig liquid pressure through the inlet test adapter. Then close the coupler poppet and apply a steady force in the closed direction while verifying that the coupler poppet shaft has opened the relief valve venting trapped liquid down-stream of the Unit's piston seat (through the hole in the seal retainer) to allow coupler poppet closure.

C. Then disengage from the test adapter, open the Unit by activating deadman and drain all test liquid through the outlet.

12.8 FLOW TESTING

Flow testing can only be accomplished in conjunction with a Digital Pressure Control System, 64235. Refer to the appropriate Set Up manual for testing methods. Excess flow testing is one additional test as outlined below.

The excess flow feature may be set at any flow rate between approximately 700-1100 gpm by using the Adjusting Screw (4-6). With the system up and flowing increase the flow rate to the desired flow rate at which the unit is to close. Turn the screw clockwise until the system shuts off. Turn the screw in small increments and wait a few seconds for reaction. If the system does not shutoff turn the screw another turn and wait. Continue until the system shuts down. Then start the flowing at a lower flow rate and increase it slowly until the system shuts down. Note the flow rate at which it stops and adjust if necessary. Turning the screw clockwise will result in an increased flow rate at which the system stops.

12.9 POST TEST PROCEDURE

After removing unit from test system place on an adapter housing and open poppet to drain fuel.

13.0 STORAGE

If it is necessary to store the unit for any length of time, install the dust cap, if present, otherwise cover the inlet

and outlet with a moisture barrier paper or film to protect it from the effects of dust and high humidity.

14.0 ILLUSTRATED PARTS CATALOG

Tables 1.0 through 6.0 tabulate the parts and sub-assemblies comprising the 64804 Model Hydrant Pressure Control Coupler including all available

options. The item numbers of the table are keyed to the exploded views or drawings shown in Figures 1 through 8.

TABLE 1.0
64804 Coupler and Options

Fig.	Item	Part Number	Description	Units/ Assy	Coupler Option	Spares/10 Units/Yr
1, 3	1	47491	Pressure Control Elbow Assy	1	All	-
1	2	44660	Dust Cap	1	All	-
	3	GF4-4A	Bolt, Hex Head	1	All	-
	4	41731	Folding Handle Assy	1	All	-
	5	29178	Pin	1	All	-
	6	GF9245-68	Cotter Pin	1	All	4
	7	29179	Spring	1	All	10
	8	GF51957-42	Screw	1	All	2
	9	29177	Handle Cam	1	All	1
	10	207355	Handle	1	All	-
	11	47245	Lower Half Coupler Assy	1	All	-
	12	GF35338-44	Lockwasher	1	All	-
	13	28781	Washer	1	All	-
	14	29216	Bearing, Shaft Seal	2	All	20
	15	MS29513-212	O-ring	1	All	10
1, 4	16	47514	Excess Flow Control Device	1	All	-
1	17	47523	Tube Assembly	1	All	-
	18	GF51843-5SSA	Adapter	1	All	-
	19	221665	Tube	1	All	-
	20	GF51815-6SSA	Elbow	1	All	-
	Option C	GF4-7A	Product Selection	5	C	-
	Option D	GF20995C32	Lockwire – Fasteners	AR	D	Roll
	Option E	54245K999-1	Adds Female Dry Break Quick Disconnect to fuel control port – See Note 3 below	1	E	-
	Option F	54245K999-2	Adds Male Dry Break Quick Disconnect to fuel control port – See Note 3 below	1	F	-
	21	2404-06-06	Fitting	1	All	-
	22	MS29512-06	Gasket	1	All	10
1, 14	23	47349	Handle, Std Transverse Carrying	1	All	-
1, 8	24	44140	Collar Stop Assy (Table 7)	1	All	-
1, 4	Option 3	47226	Male Adapter Assembly (Table 5)	1	3	-
1, 6A	Option 4	47225	Male Adapter Assembly (Table 6)	1	4	-
1, 9	Option W	60532	Carriage Assy -See Note 4	1	2, W	-
1, 15	Option Y	47182	Handle, Outlet Swivel Joint	1	Y	-
-	-	KD64804-1	Kit – Contains all soft goods (seals) and other necessary parts to overhaul a 64804 Coupler with option “2” QD. Contains items – 1-14, 1-15, 1-22, 2-10, 2-11, 2-13, 2-15D, 2-17, 2-18, 2-22, 2-23, 2-28, 2-33, 3-5, 3-7, 3-8, 3-15, 3-16, 3-23, 3-26, 3-29, 3-30, 3-31, 3-33, 3-36, 3-38, 3-39, 3-52, 3-53, 4-3, 4-4, 4-5, 4-7, 4-10, 4-15, 4-16, 4-19, 4-20, 4-22, 4-23, 4-25, 5-11, 5-12, 5-15 & 5-22.			
-	-	KD64804-2	Kit – Contains all soft goods (seals) and other necessary parts to overhaul a 64804 Coupler with option “3” QD. Contains items - 1-14, 1-15, 1-22, 2-10, 2-11, 2-13, 2-15D, 2-17, 2-18, 2-22, 2-23, 2-28, 2-33, 3-5, 3-7, 3-8, 3-15, 3-16, 3-23, 3-26, 3-29, 3-30, 3-31, 3-33, 3-36, 3-38, 3-39, 3-52, 3-53, 4-3, 4-4, 4-5, 4-7, 4-10, 4-15, 4-16, 4-19, 4-20, 4-22, 4-23, 4-25, 5-22 & 6A-7.			
-	-	KD64804-3	Kit – Contains all soft goods (seals) and other necessary parts to overhaul a 64804 Coupler with option “4”. Contains items - 1-14, 1-15, 1-22, 2-10, 2-11, 2-13, 2-15D, 2-17, 2-18, 2-22, 2-23, 2-28, 2-33, 3-5, 3-7, 3-8, 3-15, 3-16, 3-23, 3-26, 3-29, 3-30, 3-31, 3-33, 3-36, 3-38, 3-39, 3-52, 3-53, 4-3, 4-4, 4-5, 4-7, 4-10, 4-15, 4-16, 4-19, 4-20, 4-22, 4-23, 4-25, 5-22 & 7-9.			
-	-	KD64804-4	Kit – Contains all soft goods (seals) and other necessary parts to overhaul the 47491 Pressure Control Elbow for the 64804 Coupler that includes option “4”. Contains items - 1-22, 2-10, 3-5, 3-7, 3-8, 3-15, 3-16, 3-23, 3-26, 3-29, 3-30, 3-31, 3-33, 3-36, 3-38, 3-39, 3-52, 3-53, 4-5, 4-7, 5-11, 5-12, 5-15, & 6A-5.			
-	-	KD64804-5	Kit – Contains all soft goods (seals) and other necessary parts to over-haul the 47491 Pressure Control Elbow for the 64804 Coupler that includes option “3”. Contains items - 1-22, 2-10, 3-5, 3-7, 3-8, 3-15, 3-16, 3-23, 3-26, 3-29, 3-30, 3-31, 3-33, 3-36, 3-38, 3-39, 3-52, 3-53, 4-5, 4-7, 6A-5 & 6A-7.			
-	-	KD64804-6	Kit – Contains all soft goods (seals) and other necessary parts to over-haul the 47491 Pressure Control Elbow for the 64804 Coupler that includes option “4”. Contains items – 1-22, 2-10, 3-5, 3-7, 3-8, 3-15, 3-16, 3-23, 3-26, 3-29, 3-30, 3-31, 3-33, 3-36, 3-39, 3-52, 3-53, 6A-5 & 7-9.			
-	-	KD64804-7	Kit – Contains all soft goods (seals) and other necessary parts to overhaul the 47245 Lower Half Coupler Assembly for the 64804 Coupler that includes option “4”. Contains items – 1-14, 1-15, 2-10, 2-11, 2-13, 2-15D, 2-17, 2-18, 2-22, 2-23, 2-28, 2-33.			

KD64804-8

Kit – Contains all soft goods (seals) and other necessary parts to overhaul the 47514 Excess Flow Control Device for the 64804 Coupler. Contains items – 1-22, 4-3, 4-4, 4-5, 4-7, 4-10, 4-15, 4-16, 4-19, 4-20, 4-22, 4-23 & 4-25.

Notes:

1. All part numbers beginning with "GF" are interchangeable with those beginning with either "AN" or "MS". If the "GF" is followed by three numbers it is interchangeable with and "AN" part, otherwise it is interchangeable with an "MS" part of the same number.
2. The recommended spare parts shown above are the number required to support 10 Units for one year. In addition it is advisable to keep a spare Coupler Subassembly (1-11) complete with the Elbow Assy (1-E or F) to interchange with any unit in the field that may exhibit a problem. The recommended quantities are based on the ratio of spare parts sold for each unit during a one year period of time. The actual quantity required will vary from location to location.
3. Either Option E or F can be used on the coupler with the mating part not used on the coupler attached to the hose.
4. Use 60532C Carriage Assembly with Options 3 or 4 Outlet Adapters.

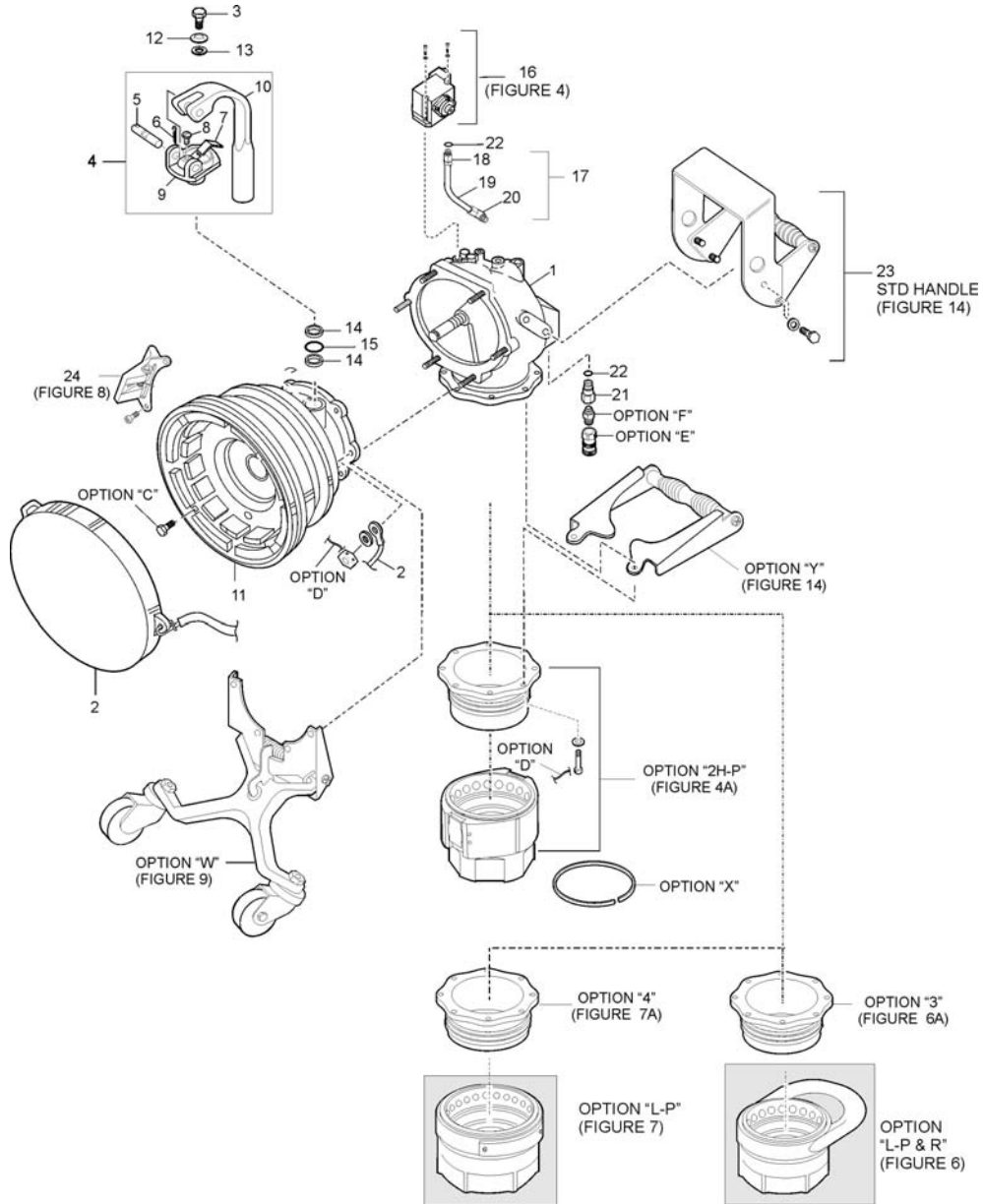

FIGURE 1
64804 HYDRANT COUPLER & OPTIONS

TABLE 2.0

Lower Coupler Half

Fig.	Item	Part Number	Description	Units/ Assy	Coupler Option	Spares/10 Units/Yr
2		47245	Coupler, Lower Half without handle	1	All	-
	1-4		Left intentionally blank			
	5	43945	Body	1	All	-
	6	GF4-4A	Bolt	1	All	-
	7	GF35338-44	Lockwasher	1	All	-
	8	28781	Washer	1	All	-
	9	201286	Key	1	All	-
	10	MS29513-249	O-ring.....	1	All	10
	11	202010	Cotter Pin	1	All	10
	12	NAS1169C10	Washer	1	All	-
	13	28765	Bearing	1	All	5
	14	210004	Pin	1	All	1
	15	47064-3	Poppet Assembly	1	All	1
	15B	LP57G82P8	Screw	4	All	1
	15C	220276	Poppet.....	1	All	1
	15D	MS29513-037	O-ring	1	All	10
	15E	220275	Shaft.....	1	All	1
	16	209601	Link.....	1	All	1
	17	28755	Seal, Nose.....	1	All	10
	18	209837-347	Quad Ring	1	All	10
	19	210587	Wave Washer	1	All	-
	20	209996	Crank Shaft	1	All	-
	21	200103	Washer	1	All	2
	22	203563	Bearing	1	All	10
	23	29221	Bearing	1	All	10
	26	200689	Detent Pin.....	1	All	-
	27	207482	Collar	1	All	1
	28	28928	Bumper.....	1	All	5
	29	RR-800-S	Retaining Ring.....	1	All	-
	30	GF19060-4815	Ball.....	1	All	-
	31	28763	Spring	1	All	-
	32	28760	Lug Ring	4	All	4
	33	221860	Lug (3 rd edition)	16	All but A	16
	33A	200688	Lug (2 nd edition)	16	A	16
	34	GF3-3A	Bolt	1	All	-
	35	GF960C10L	Washer	1	All	-
	36	GF35333-39	Lockwasher	1	All	-

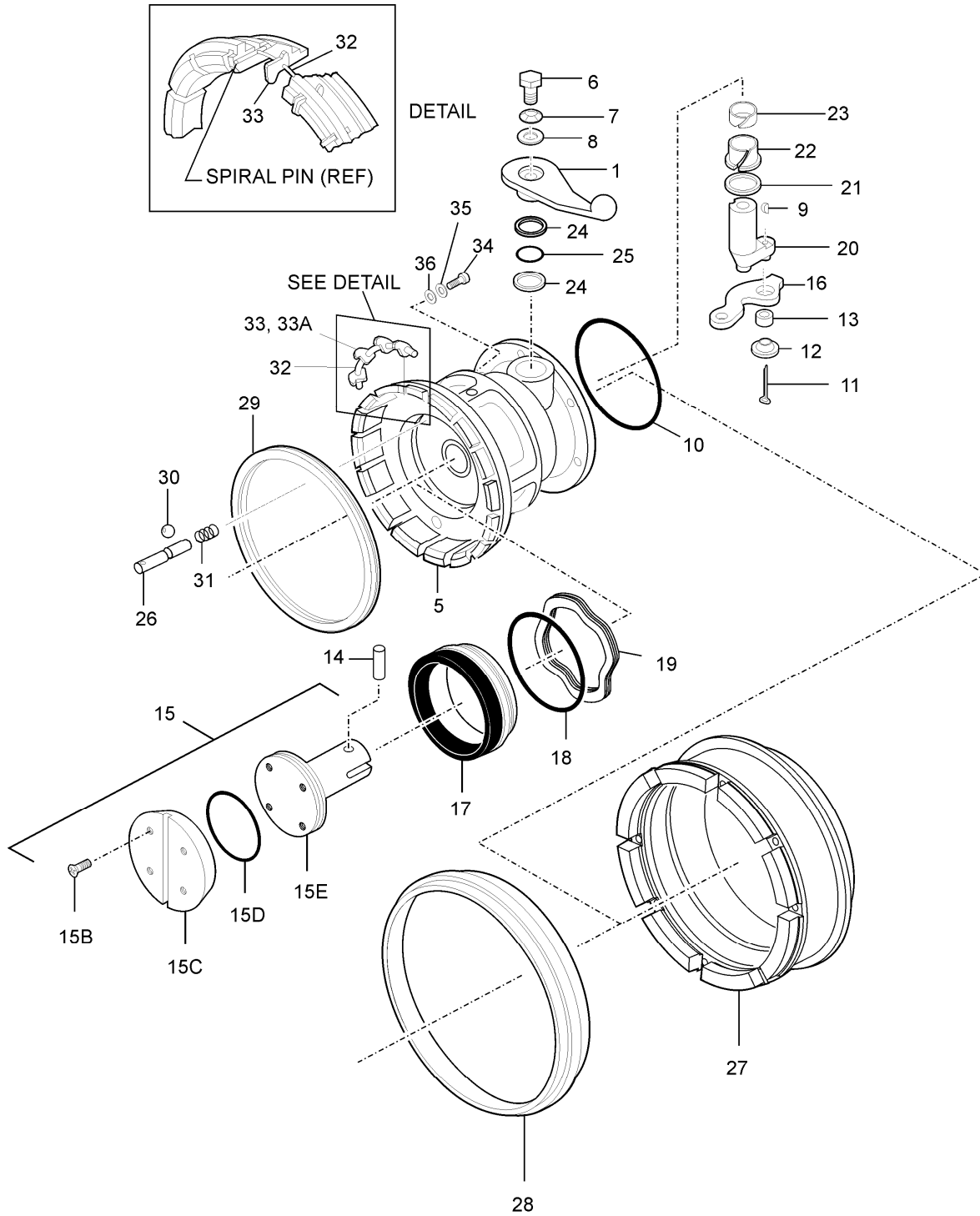
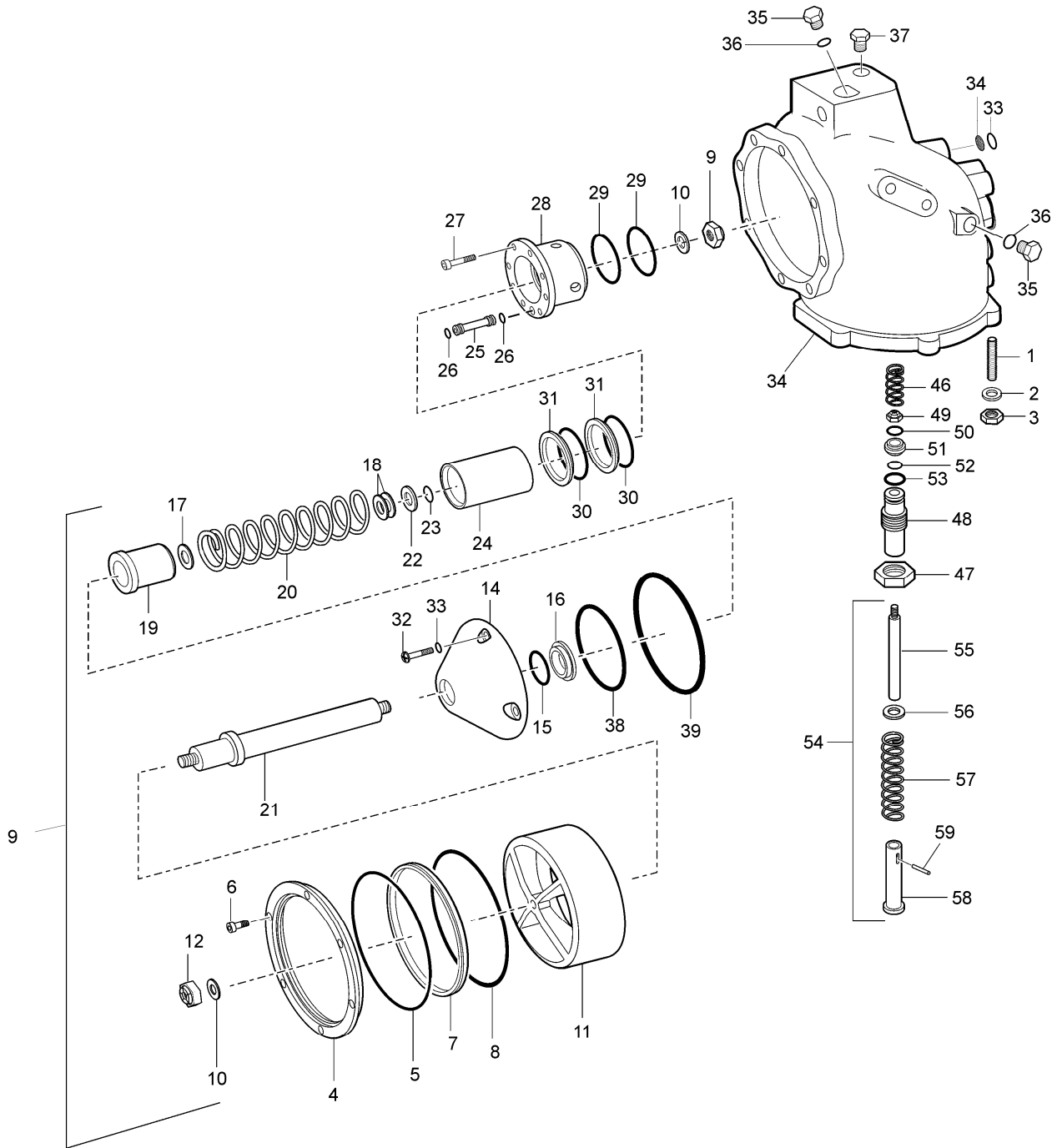

FIGURE 2
64804 LOWER COUPLER HALF ASSEMBLY

TABLE 3.0
Pressure Control Elbow Assy

Fig.	Item	Part Number	Description	Units/ Assy	Coupler Option	Spares/10 Units/Yr
1	1	47492	Pressure Control Elbow Assy.....	1	All	1
3	1	GF565AC524H32	Stud	6	All	-
	2	GF35338-45	Washer.....	6	All	-
	3	GF9882-11	Nut.....	6	All	-
	4	220961	Housing, Seal.....	1	All	-
	5	MS29513-042	O-Ring.....	1	All	-
	6	GF16997-18	Screw, Socket Head Cap	6	All	-
	7	220665	Seal, Outer Piston	1	All	10
	8	MS29513-151	O-ring.....	1	All	10
	9	47348	Piston Assembly.....	1	All	-
	10	GF960C616L	Washer*.....	2	All	-
	11	220666	Piston, Outer*.....	1	All	3
	12	50FK-624	Nut*.....	2	All	-
	13	Left intentionally blank				
	14	221641	Retainer, Piston Seal.....	1	All	-
	15	203565	O-ring	1	All	10
	16	221595	Seal	1	All	10
	17	5610-381-50	Washer, Teflon	1	All	-
	18	5720-158-25	Washer, Bronze.....	2	All	-
	19	221594	Guide, Spring	1	All	-
	20	200757	Spring	1	All	-
	21	202290	Shaft	1	All	-
	22	202291	Washer, Precision	1	All	-
	23	MS29513-012	O-ring	1	All	10
	24	200759	Piston, Small	1	All	-
	25	220962	Tube Connector.....	1	All	-
	26	MS29513-006	O-ring.....	2	All	20
	27	GF16997-32L	Screw.....	4	All	-
	28	221307	Housing, Seal	1	All	-
	29	MS29513-134	O-ring.....	2	All	20
	30	MS29513-129	O-ring.....	2	All	20
	31	200758	Seal	2	All	20
	32	220685-1250	Screw.....	4	All	-
	33	MS29513-008	O-ring.....	4	All	40
	34	47492	Housing Assembly.....	1	All	-
	35	GF51840-23	Plug	2	All	-
	36	MS29512-04	Gasket	2	All	20
	37	40427	Breather Plug Assy.....	1	All	-
	38	MS29513-038	O-ring.....	1	All	10
	39	201201-231	O-ring.....	1	All	10
	40-45	Left intentionally blank				
	46	29436	Spring	1	All	-
	47	200761	Nut	1	All	-
	48	200752	Screw, Pressure Relief Adjustment.....	1	All	-
	49	GF21083C04	Nut.....	1	All	-
	50	NAS620C4	Washer	1	All	-
	51	29555	Retainer, Seal.....	1	All	-
	52	M83248/2-008	O-ring.....	1	All	10
	53	MS29513-011	O-ring.....	1	All	10
	54	44229	Shaft Assy, Pressure Relief.....	1	All	-
	55	221605	Shaft	1	All	-
	56	5710-83-32	Washer	1	All	-
	57	207519	Spring	1	All	-
	58	221606	Slide	1	All	-
	59	MS16562-194	Pin	1	All	-



* 9 contains items 10,11, 12, 14, 15, 16, 19, 20, 21, 22, 23 & 24.
 Items 32, 33, 38 & 39 are not part of 9.

FIGURE 3
47491 PRESSURE CONTROL ELBOW ASSY FOR 64804

TABLE 4.0
Excess Flow Control Device

Fig.	Item	Part Number	Description	Units/ Assy	Coupler Option	Spares/10 Units/Yr
1	7	47514	Excess Flow Control Device	1	All	-
4	1	GF19998-42	Screw	2	All	-
	2	GF960C416L	Washer	2	All	-
	3	MS29513-008	O-ring	1	All	10
	4	MS29513-010	O-ring	1	All	10
	5	MS29513-011	O-ring	1	All	10
	6	29484	Screw, Adjusting	1	All	-
	7	MS29513-006	O-ring	1	All	10
	8	GFGF19998-27	Screw	4	All	-
	9	NAS620C10L	Washer	4	All	-
	10	MS29513-030	O-ring	1	All	10
	11	29483	Cover	1	All	-
	12	29482	Retainer, Spring	1	All	-
	13	28962	Spring	1	All	-
	14	41669	Piston Assembly	1	All	-
	15	28967	Slipper Seal	1	All	10
	16	M25988/3-128	O-ring	1	All	10
	17	GF24693-C25	Screw, Flat Head	2	All	-
	18	28958	Retainer, Latch Stem	1	All	-
	19	28956	Slipper Seal, Latch Stem	1	All	10
	20	MS29513-007	O-ring	1	All	10
	21	221648	Retainer, Seal	1	All	-
	22	MS29513-014	O-ring	1	All	10
	23	MS29513-012	O-ring	1	All	10
	24	221649	Plunger, Reset	1	All	-
	25	221499	O-ring	2	All	20
	26	28964	Spring	1	All	-
	27	221650	Manifold	1	All	-

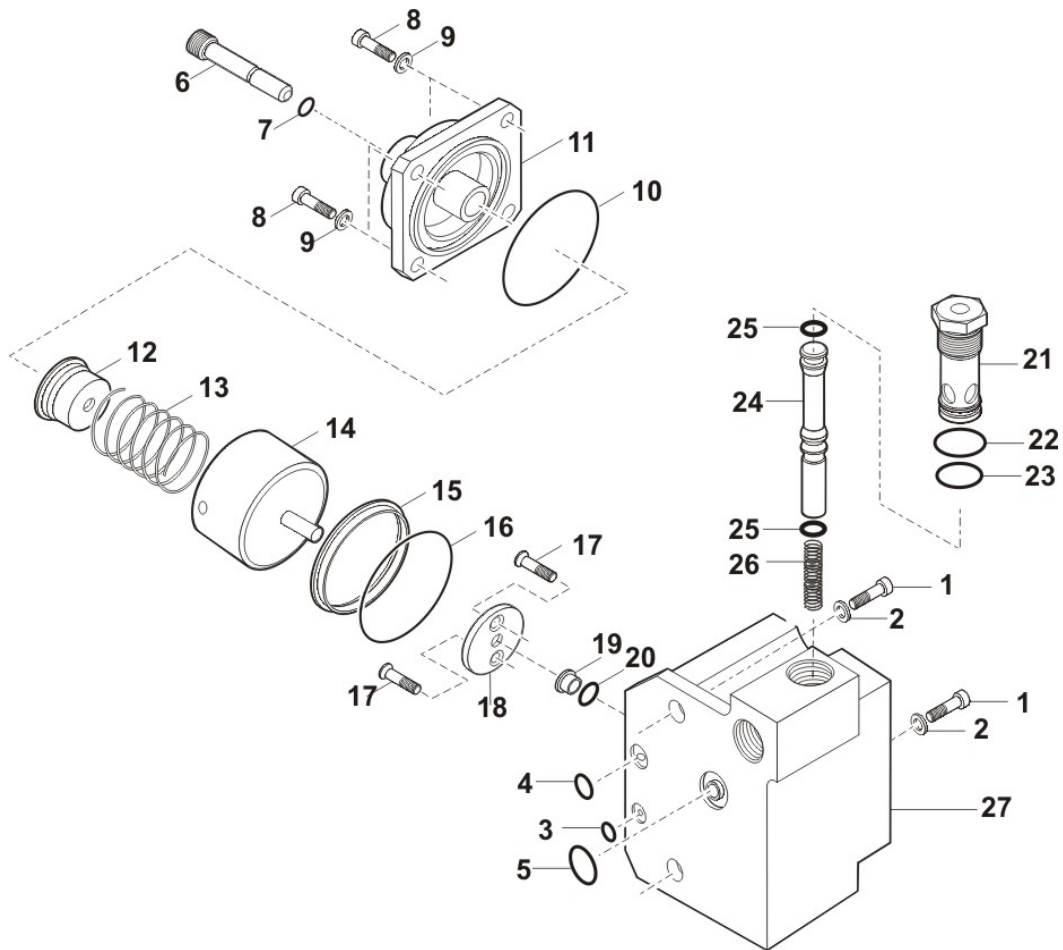

FIGURE 4
EXCESS FLOW CONTROL DEVICE

TABLE 5

Option "2" Quick Disconnect Assy.

Fig.	Item	Part Number	Description	Units / Assy	Coupler Option	Spares/10 Units/Yr
5	1	47152-5	Female Half, QD, 2" NPT (Note 5).....	1	2Q	-
	1A	220876-5	Body, Coupling, 2" NPT.....	1	2Q	-
	2	200924	Ring, Retaining.....	1	All "2"	-
	3	220874	Retainer, Spring.....	1	All "2"	-
	4	220873	Spring.....	1	All "2"	-
	5	GF19060-4818	Ball.....	16	All "2"	-
	6	No Part Number	Sleeve Assy.....	1	All "2"	-
	7	210151-3	Pin.....	2	All "2"	-
	8	209885	Lever, Interlock.....	2	All "2"	-
	9	209946	Spring, Torsion.....	2	All "2"	-
	10	220871	Sleeve, Ball Retainer.....	1	All "2"	-
	11	220872	Wear Ring.....	2	All "2"	20
1	12	MS29513-341	O-ring.....	1	All "2"	10
	1	47152-6	Female Half, QD, 2" BSPP.....	1	2S	-
	1A	220876-6	Body, Coupling, 2" BSPP.....	1	2S	-
	2	200924	Ring, Retaining.....	1	All "2"	-
	3	220874	Retainer, Spring.....	1	All "2"	-
	4	220873	Spring.....	1	All "2"	-
	5	GF19060-4818	Ball.....	16	All "2"	-
	6	No Part Number	Sleeve Assy.....	1	All "2"	-
	7	210151-3	Pin.....	2	All "2"	-
	8	209885	Lever, Interlock.....	2	All "2"	-
	9	209946	Spring, Torsion.....	2	All "2"	-
	10	220871	Sleeve, Ball Retainer.....	1	All "2"	-
1	11	220872	Wear Ring.....	2	All "2"	20
	12	MS29513-341	O-ring.....	1	All "2"	10
	1	47152-4	Female Half, QD, 2 1/2" NPT.....	1	2H	-
	1A	220876-4	Body, Coupling, 2 1/2" NPT.....	1	2H	-
	2	200924	Ring, Retaining.....	1	All "2"	-
	3	220874	Retainer, Spring.....	1	All "2"	-
	4	220873	Spring.....	1	All "2"	-
	5	GF19060-4818	Ball.....	16	All "2"	-
	6	No Part Number	Sleeve Assy.....	1	All "2"	-
	7	210151-3	Pin.....	2	All "2"	-
	8	209885	Lever, Interlock.....	2	All "2"	-
	9	209946	Spring, Torsion.....	2	All "2"	-
10	220871	Sleeve, Ball Retainer.....	1	All "2"	-	
1	11	220872	Wear Ring.....	2	All "2"	20
	12	MS29513-341	O-ring.....	1	All "2"	10
	1	47152-3	Female Half, QD, 2 1/2" BSPP.....	1	2K	-
	1A	220876-3	Body, Coupling, 2 1/2" BSPP.....	1	2K	-
	2	200924	Ring, Retaining.....	1	All "2"	-
	3	220874	Retainer, Spring.....	1	All "2"	-
	4	220873	Spring.....	1	All "2"	-
	5	GF19060-4818	Ball.....	16	All "2"	-
	6	No Part Number	Sleeve Assy.....	1	All "2"	-
	7	210151-3	Pin.....	2	All "2"	-
	8	209885	Lever, Interlock.....	2	All "2"	-
	9	209946	Spring, Torsion.....	2	All "2"	-
10	220871	Sleeve, Ball Retainer.....	1	All "2"	-	
1	11	220872	Wear Ring.....	2	All "2"	20
	12	MS29513-341	O-ring.....	1	All "2"	10
	1	47152-2	Female Half, QD, 3" NPT.....	1	2L	-
	1A	220876-2	Body, Coupling, 3" NPT.....	1	2L	-
	2	200924	Ring, Retaining.....	1	All "2"	-
	3	220874	Retainer, Spring.....	1	All "2"	-
	4	220873	Spring.....	1	All "2"	-
	5	GF19060-4818	Ball.....	16	All "2"	-
	6	No Part Number	Sleeve Assy.....	1	All "2"	-
	7	210151-3	Pin.....	2	All "2"	-
	8	209885	Lever, Interlock.....	2	All "2"	-

Fig.	Item	Part Number	Description	Units / Assy	Coupler Option	Spares/10 Units/Yr
5	9	209946	Spring, Torsion	2	All "2"	-
	10	220871	Sleeve, Ball Retainer.....	1	All "2"	-
	11	220872	Wear Ring.....	2	All "2"	20
	12	MS29513-341	O-ring.....	1	All "2"	10
	1	47152-1	Female Half, QD, 3" BSPP.....	1	2M	-
	1A	220876-1	Body, Coupling, 3" BSPP	1	2M	-
	2	200924	Ring, Retaining	1	All "2"	-
	3	220874	Retainer, Spring.....	1	All "2"	-
	4	220873	Spring	1	All "2"	-
	5	GF19060-4818	Ball.....	16	All "2"	-
	6	No Part Number	Sleeve Assy.....	1	All "2"	-
	7	210151-3	Pin	2	All "2"	-
	8	209885	Lever, Interlock	2	All "2"	-
	9	209946	Spring, Torsion	2	All "2"	-
	10	220871	Sleeve, Ball Retainer.....	1	All "2"	-
	11	220872	Wear Ring.....	2	All "2"	20
	12	MS29513-341	O-ring.....	1	All "2"	10
	1	47292-1	Female Half, QD, 4" BSPP.....	1	2N	-
	5	GF19060-4818	Ball.....	16	All "2"	-
	6	No Part Number	Sleeve Assy.....	1	All "2"	-
	7	210151-3	Pin, Expansion	2	All "2"	-
	8	209885	Lever	2	All "2"	-
9	209946	Spring, Torsion	2	All "2"	-	
10	220871	Sleeve, Ball Retainer.....	1	All "2"	-	
11	220872	Wear Ring.....	2	All "2"	20	
12	MS29513-341	O-ring.....	1	All "2"	10	
13	NAS1352N3-8	Screw.....	12	2N, P	-	
14	221163-2	Fitting.....	1	2N	-	
15	MS29513-045	O-ring.....	1	2N,P	10	
16	47291	Body, Coupling	1	2N, P	-	
1	47292-2	Female Half, Thumblatch QD, 4" NPT	1	2P	-	
4	220873	Spring	1	All "2"	-	
5	GF19060-4818	Ball.....	16	All "2"	-	
6	No Part Number	Sleeve Assy.....	1	All "2"	-	
7	210151-3	Pin, Expansion	2	All "2"	-	
8	209885	Lever	2	All "2"	-	
9	209946	Spring, Torsion	2	All "2"	-	
10	220871	Sleeve, Ball Retainer.....	1	All "2"	-	
11	220872	Wear Ring.....	2	All "2"	20	
12	MS29513-341	O-ring.....	1	All "2"	10	
13	NAS1351N3-8	Screw.....	12	2N, P	-	
14	221163-1	Fitting.....	1	2P	-	
15	MS29513-045	O-ring.....	1	2N,P	10	
16	47291	Body, Coupling	1	2N, P	-	
17	47198	Adapter Assembly, Male Half.....	1	All "2"	-	
18	220890	Adapter, Male Half.....	1	All "2"	-	
19	200923	Wire Race.....	2	All "2"	-	
20	GF24673-12	Screw.....	8	All "2"	-	
21	5710-63-30	Washer	8	All "2"	-	
22	MS29513-041	O-ring.....	1	All "2"	10	

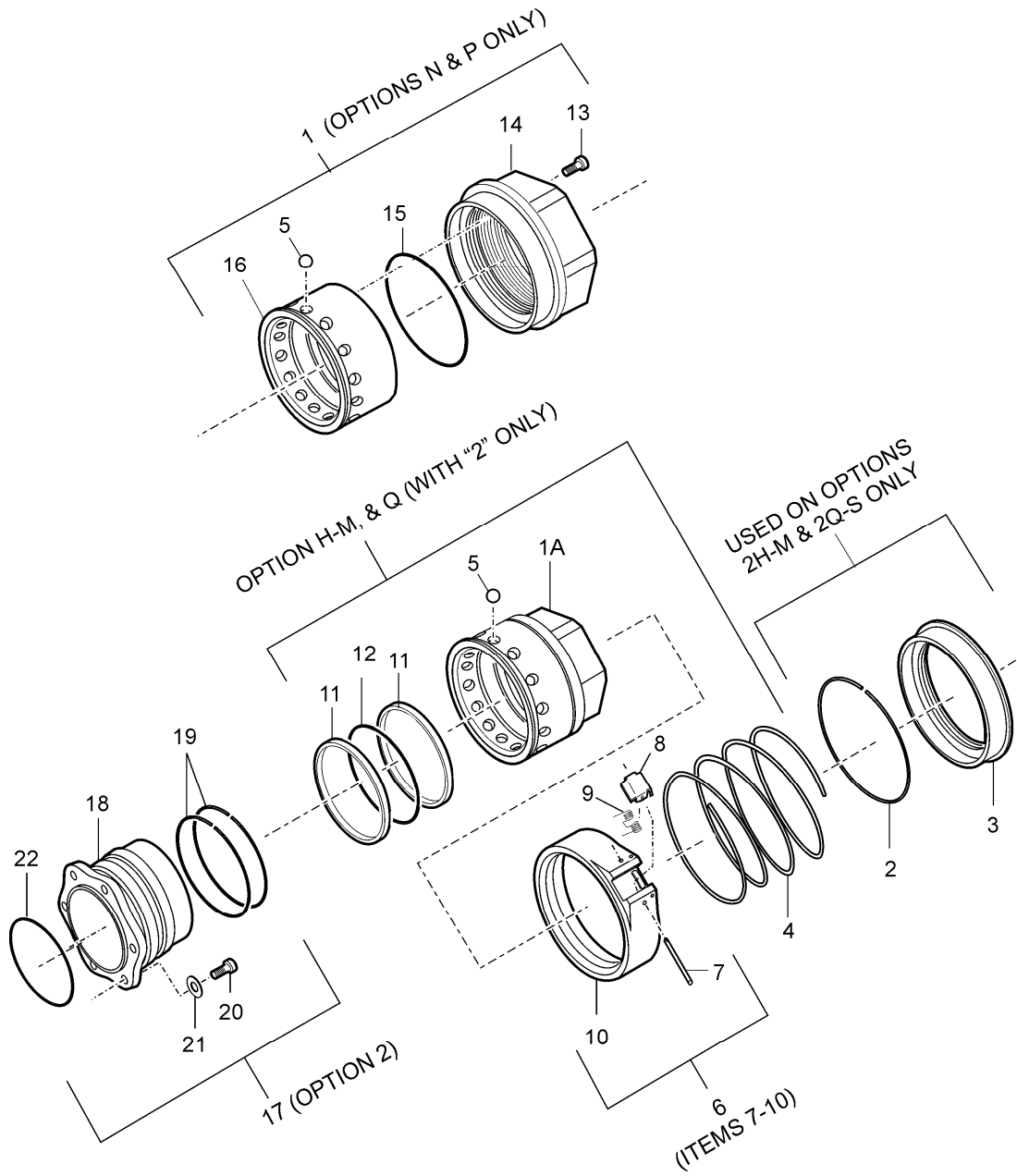

FIGURE 5
OPTION 2 QUICK DISCONNECT ASSEMBLY

TABLE 6.0
Option "3" Male Half & Options L-P Mating Female Quick Disconnect Assemblies

Fig.	Item	Part Number	Description	Units/ Assy	Coupler Option	Spares/10 Units/Yr
1	Options L-R	41730-1 to -5	Female Half.....	1	L, M, N, P	-
6	1	26961	Lock Ring.....	1	All	-
	2	GF35276-261	Screw.....	2	All	-
	3	GF20995C32	Lockwire.....	AR	AR	-
	4	28383	Retainer.....	1	All	-
	5	29173	Housing, 4" NPT.....	1	P	-
		29174	Housing, 4" BSPP.....	1	N	-
		29175	Housing, 4"NPSC.....	1	R	-
		27374	Housing, 3" NPT.....	1	L	-
		27377	Housing, 3" BSPP.....	1	M	-
	6	28779	Sleeve.....	1	All	-
7	26962	Retaining Ring.....	1	All	-	
8	GF19060-4818	Ball.....	24	All	-	
6A	Option 3	47274	Adapter Assembly, Male QD.....	1	3	-
	1	221141	Adapter.....	1	3	-
	2	28382	Wire Race.....	2	3	-
	3	GF9882-10	Nut.....	8	3	-
	4	GF35338-44	Washer.....	8	3	-
	5	MS29513-041	O-ring.....	1	3	10
	6	GF565AC428H20	Set Screw.....	8	3	-
	7	201201-348	O-ring.....	1	3	10

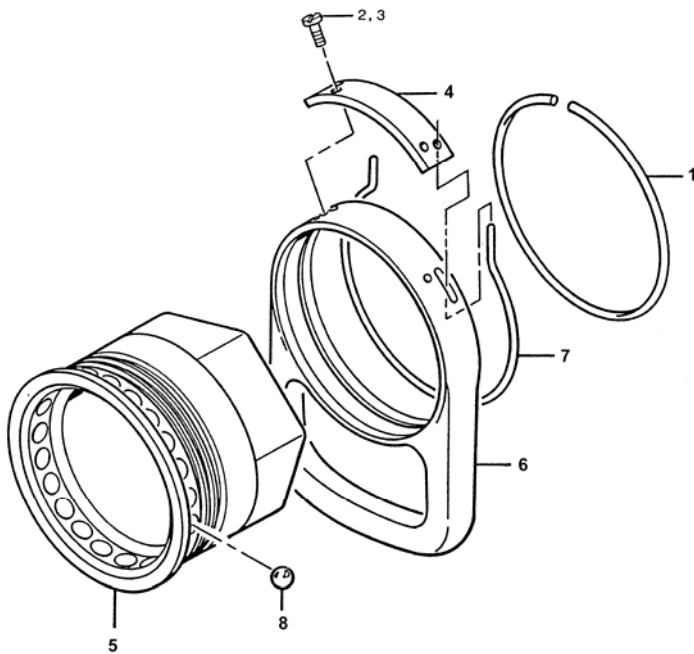

FIGURE 6
OPTION 3 QUICK DISCONNECT
ASSEMBLIES

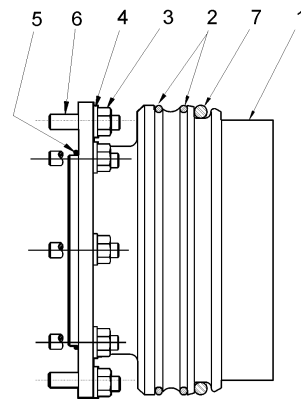

FIGURE 6A
OPTION 3 QUICK DISCONNECT ASSEMBLIES

TABLE 7.0
Option "4" Male Half & Options L-R Mating Female Quick Disconnect Assemblies

Fig.	Item	Part Number	Description	Units/ Assy	Coupler Option	Spares/10 Units/Yr
1	Options L-P	44220-1 to -4	Female Half.....	1	Options L, M, N & P	-
7	1	26961	Lock Ring	1	All	-
	2	GF35276-261	Screw	2	All	-
	3	GF20995C32	Lockwire.....	AR	AR	-
	4	28383	Retainer, Ring	1	All	-
	5	207253-1	Housing, 3" NPT.....	1	L	-
		207253-2	Housing, 3" BSPP	1	M	-
		207253-3	Housing, 4" NPT.....	1	P	-
		207253-4	Housing, 4" BSPP	1	N	-
	6	26960	Sleeve, Ball Retainer.....	1	All	-
	7	26962	Retaining Ring.....	1	All	-
8	GF19060-4818	Ball	24	All	-	
9	220552	Seal, Teflon	1	All	10	
1	Option 4	47275	Adapter Assembly, Male QD.....	1	4	-
7A	1	221143	Adapter, Male QD.....	1	4	-
	2	207483	Wire, Ball Race.....	2	4	-
	3	GF9882-10	Nut.....	8	4	-
	4	GF35338-041	Washer, Lock	8	4	-
	5	MS29513-041	O-ring	1	4	10
	6	GF565AC428H20	Set Screw	8	4	-

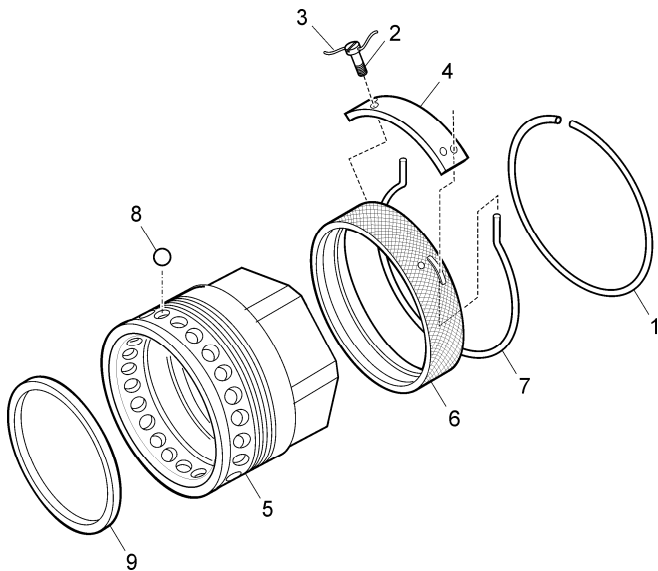

FIGURE 7
OPTION 4 QUICK DISCONNECT
ASSEMBLIES

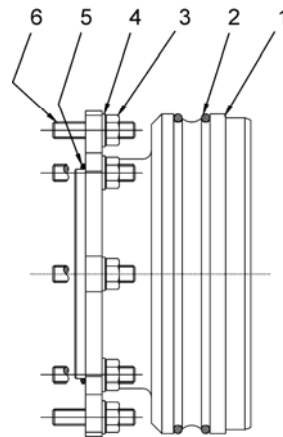

FIGURE 7A
OPTION 4 QUICK DISCONNECT ASSEMBLIES

TABLE 8.0
Collar Stop Assy

Fig.	Item	Part Number	Description	Units/ Assy	Coupler Option	Spares/10 Units/Yr
1	24	44140	Collar Stop Assy.....	1	All	-
8	1	207165	Stop, Collar.....	1	All	-
	2	207166	Bracket.....	1	All	-
	3	207167	Spring, Torsion.....	1	All	1
	4	MS20392-2C63	Pin.....	1	All	-
	5	MS24665-151	Cotter Pin.....	1	G	2

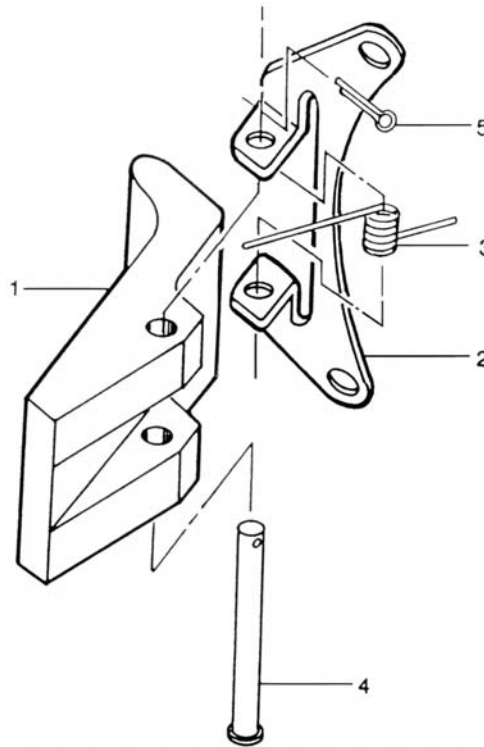
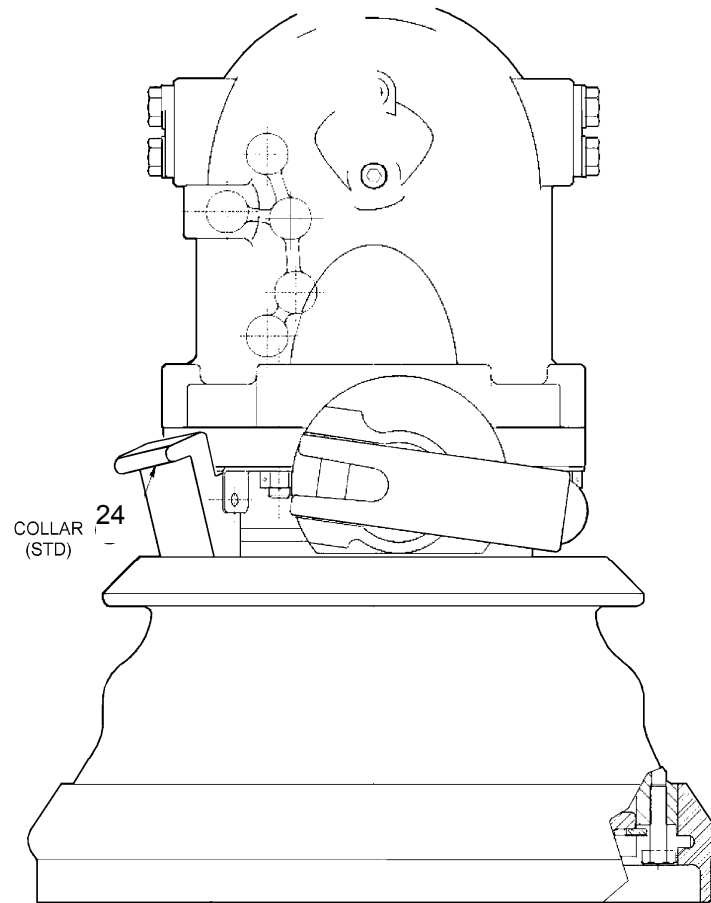

FIGURE 8
COLLAR STOP LOCK ASSEMBLY



The Collar Lock Assembly is assembled to the coupler in location shown using two of the studs from the elbow assembly and the existing Nuts (3-3) and Washers (3-4).

FIGURE 8A
OPTION G COLLAR LOCK ASSEMBLY MOUNTING INSTRUCTIONS

TABLE 9.0

60532 Carriage Assy, Option W

Fig.	Item	Part Number	Description	Units/ Assy	Coupler Option	Spares/10 Units/Yr
1	W	60532	Carriage Assy.....	1	W	-
9	1	GF51971-4	Nut.....	2	W	-
	2	GF35338-47	Washer.....	2	W	-
	3	203577	Caster.....	2	W	-
	4	GF35206-296	Screw.....	2	W	-
	5	GF35333-41	Washer.....	2	W	-
	6	GF960-816L	Washer.....	6	W	-
	7	29745	Shaft.....	1	W	-
	8	29663	Spring, Torsion.....	1	W	-
	9	29664	Flange.....	1	W/option 2	-
		47078	Flange Assy with Spacers.....	1	W/options 3 & 4	-
	10	201041	Lever.....	1	W	-
	11	29665	Spring.....	1	W	-
	12	GF960-616L	Washer.....	3	W	-
	13	29662	Latch.....	1	W	2
	14	GF9245-44	Cotter.....	1	W	-
	15	GF20392-5C73	Pin, Clevis.....	1	W	-
16	29667	Strut.....	1	W	-	

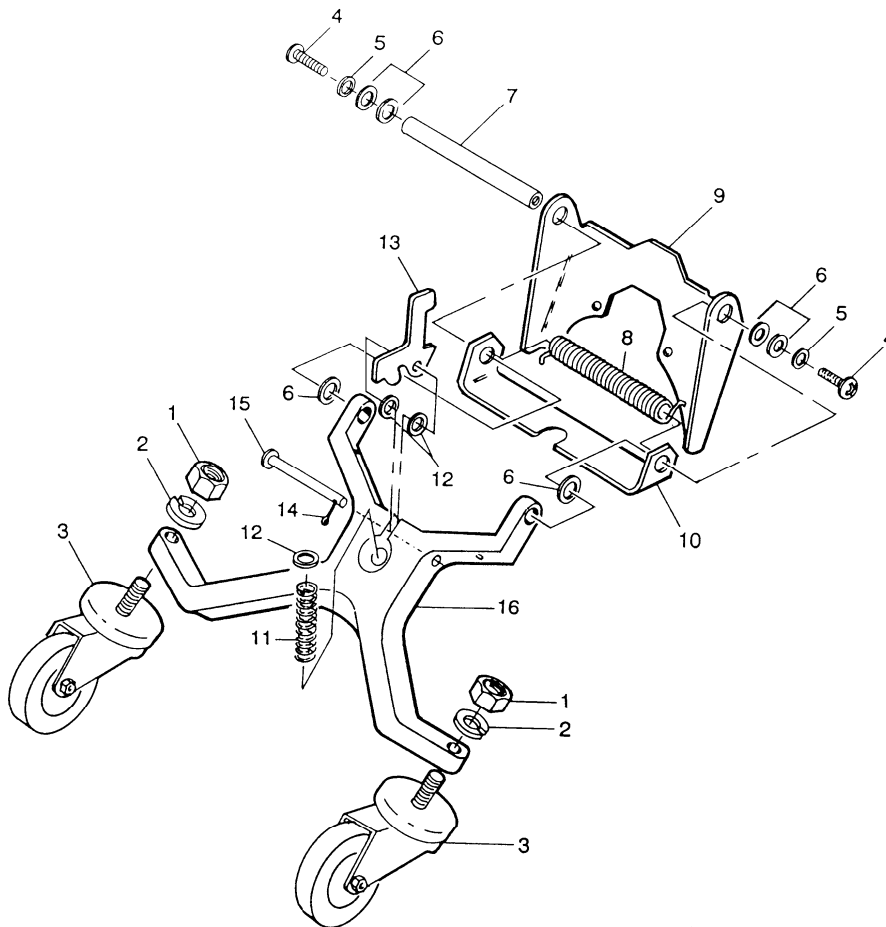
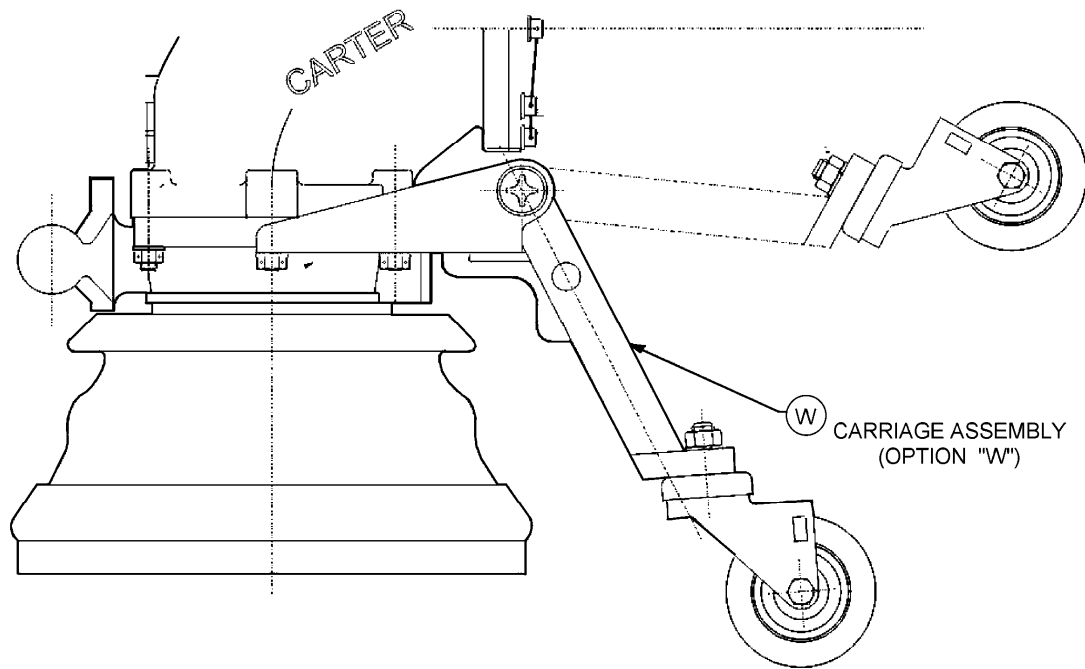

FIGURE 9
60532 CARRIAGE ASSEMBLY
OPTION W TO 64804



The carriage is assembled by removing four (4) of the Nuts (3-3) and Washers (3-4), placing the carriage in place and reinstalling the nuts and washers as noted in paragraph 9.8.

FIGURE 9A
CARRIAGE INSTALLATION INSTRUCTIONS

Table 10
47349 Standard Transverse Carrying Handle

Fig.	Item	Part Number	Description	Units/ Assy	Coupler Option	Spares/10 Units/Yr
1	23	47349	Carrying Handle Assy	1	All	-
10	1	220969	Side Plate, Handle.....	2	All	-
	2	GF960-516L	Washer	6	All	-
	3	GF18153-33	Screw, Hex Head.....	4	All	-
	4	GF35207-296	Screw, Pan Head.....	2	All	-
	5	220970	Bar, Handle.....	1	All	-
	6	220971	Grip, Handle	2	All	2
	7	221253	Bracket, Guard	1	All	-

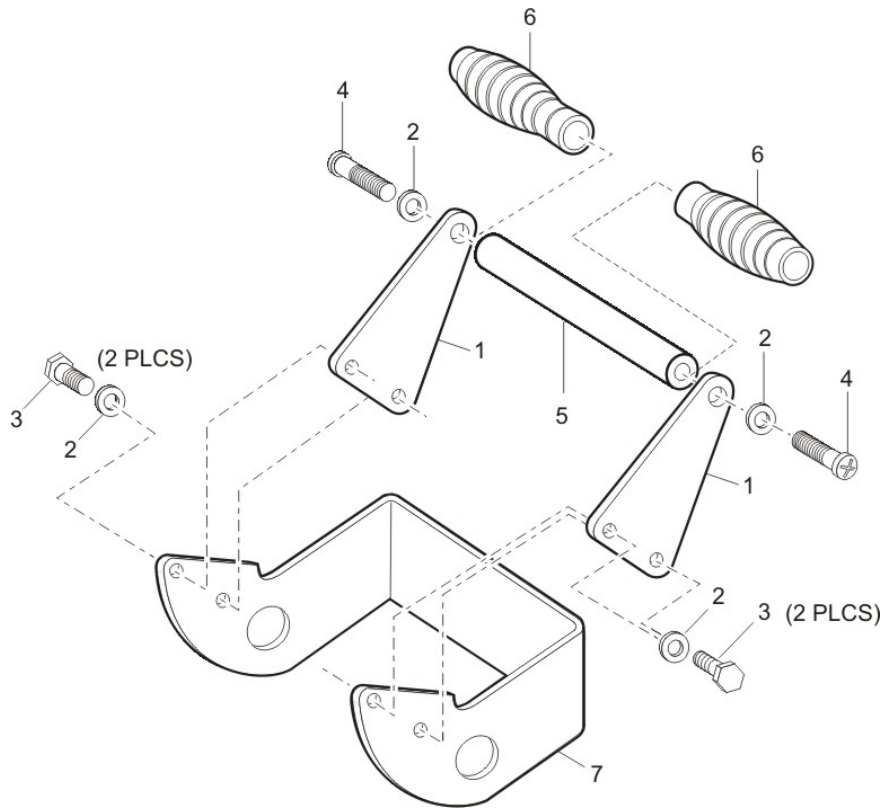

FIGURE 10
STANDARD TRANSVERSE CARRYING HANDLE

Table 11
47182 Carrying Handle, Option "Y"

Fig.	Item	Part Number	Description	Units/ Assy	Coupler Option	Spares/10 Units/Yr
1	Y	47182	Carrying Handle Assy	1	Y	-
11	1	220972-2	Side Plate -2	1	Y	-
	2	220972-1	Side Plate -1	1	Y	-
	3	220970	Bar, Handle.....	1	Y	-
	4	220971	Grip, Handle	2	Y	2
	5	GF960-516L	Washer	2	Y	-
	6	GF35207-296	Screw.....	2	Y	-

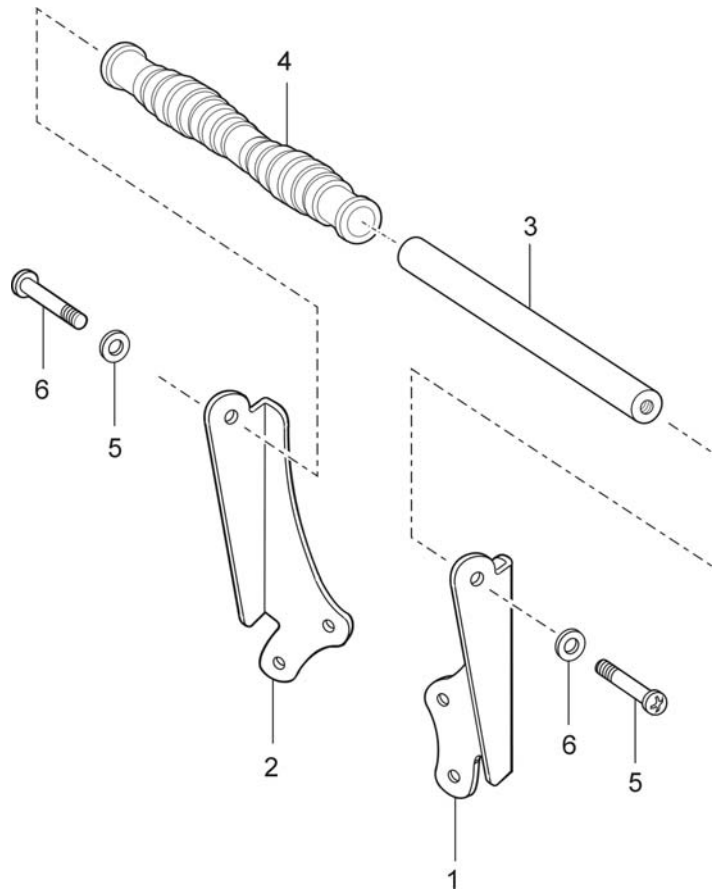
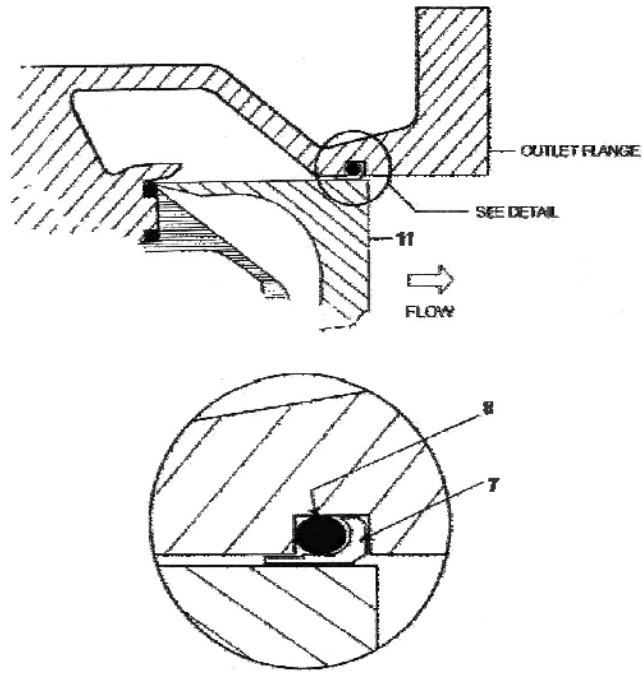

FIGURE 11
OPTION Y CARRYING HANDLE



The figure above is intended for an in-line pressure control valve hence the presence of a flange. Ignore that part of the figure. This will be corrected on the next issue.

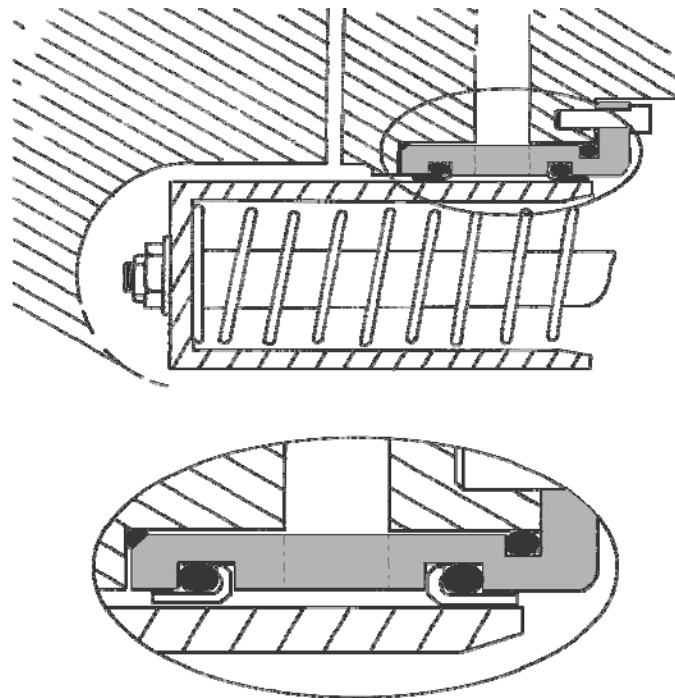

FIGURE 12
INNER PISTON SEAL INSTALLATION

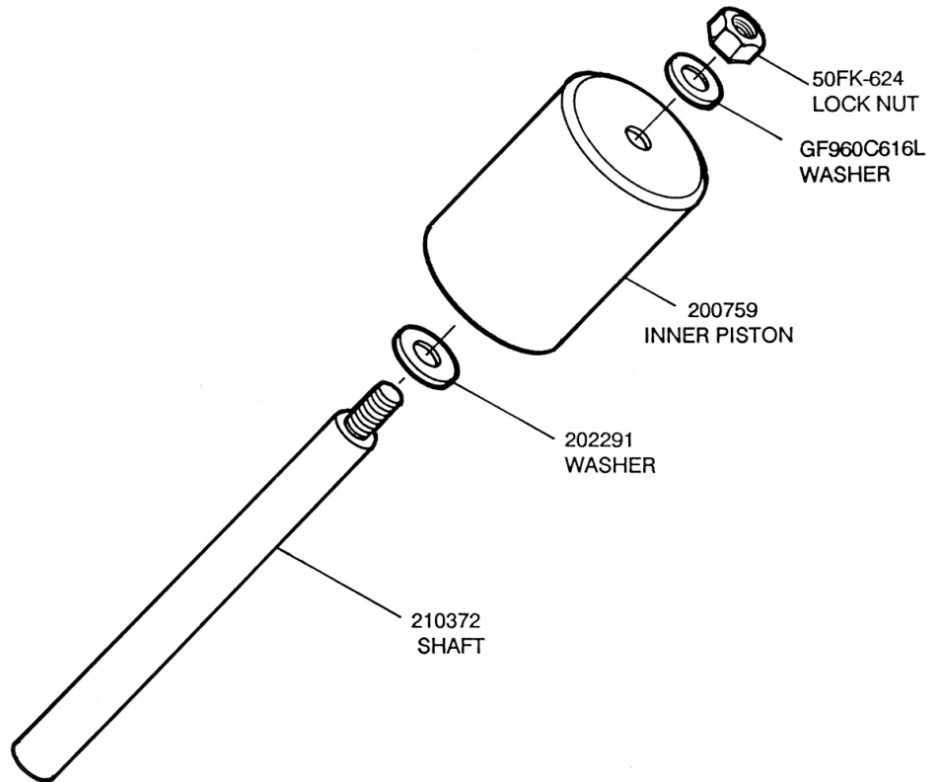

FIGURE 13
INNER SEAL POLISHING TOOL

15.0 OBSOLETE PARTS INFORMATION

There is a long history of Eaton's Carter brand lower half coupler changes that, through the years has not been particularly explained. The reasons for these changes are now lost. This section applies only to couplers that have been retrofitted from a 60700-1, 60600 or 60600-1. If the lower half coupler has been retained then this section is applicable. For information on obsolete parts for the older lower half coupler see the manuals for the 60700-1, 60600, or 60600-1.

Aerospace Group
Conveyance Systems Division
9650 Jeronimo Road
Irvine, CA 92618
Ph: (949) 452-9500
Fax: (949) 452-9992



Powering Business Worldwide