



*Powering Business Worldwide*

Aerospace Group  
Conveyance Systems Division  
Carter® Brand  
Ground Fueling Equipment

**SM60672-1**

November 1, 2011

Applicable additional manuals:  
SM60427 Nozzle

## **Maintenance Manual**

---

### **Dry Break Quick Disconnect (Old Style)**

**To Mate Model 60427 Nozzle**

---

**Model 60672-1**

**TABLE OF CONTENTS**

	<u>Page</u>
1.0 Introduction.....	3
2.0 Equipment Description .....	3
3.0 Table of Options .....	3
4.0 Special Tools.....	4
5.0 Disassembly .....	4
6.0 Inspection .....	5
7.0 Reassembly.....	5
8.0 Test .....	6
9.0 Illustrated Parts Catalog.....	6
Figure 1 .....	8
Figure 2 .....	9
Figure 3 .....	10
Figure 4 .....	11

## Maintenance, Overhaul & Test Instructions

### Model 60672-1 Quick Disconnect

#### 1.0 INTRODUCTION

This manual furnishes detailed instructions covering the maintenance and overhaul of Eaton's Carter brand Model 60672-1 dry break quick disconnect.

The 60672-1 Dry Break Disconnect was made in many variations of inlet configurations. They were obtained by procuring different option letters appended as suffixes to the basic model number, 60672-1. Each of these variations corresponded to a different "option" letter on the 60427 Nozzle when procured as a part of the nozzle. Refer to paragraph 3.0

for a detailed explanation of the various options.

The Model 60672-1 dry break disconnect has been superseded in production by an improved unit under part number 61154 with various options to obtain different configurations. See your Eaton Carter brand distributor for additional information. Spare part support for all seals and internal parts will continue. Many of the internal parts are identical to those used in the newer version.

#### 2.0 EQUIPMENT DESCRIPTION

Carter Model 60672-1 dry break disconnect is designed to be used as a part of Carter's 60427 Nozzle, to provide connection to various sizes and types of hose fittings and to provide a quick means of disconnecting

the nozzle from the hose for inspection of the screen utilized therein. The outlet adapter that mates the nozzle is also the male half of the disconnect.

#### 3.0 TABLE OF OPTIONS

The quick disconnect was available with various inlet thread sizes and types as shown below. The corresponding options to Model 60427 nozzle used to obtain it as a part of the nozzle are also shown. The addition of the new 61154 dry break disconnect to the 60427 nozzle affects the part numbering system. See Bulletin 60427 for further information or contact your

Carter distributor. **The male half adapter connection to the female half of the 60672-1 series units is not interchangeable with the corresponding items of the new 61154. Hence if it is necessary to replace the major housing or male adapter, it may be necessary or more economical to procure a 61154.**

Part Number	Description	Nozzle Option
60672-1H	2 ½" NPT Inlet Thread	XX
60672-1K	2 ½" BSPP Inlet Thread	YY
60672-1L	3" NPT Inlet Thread	VV
60672-1M	3" BSPP Inlet Thread	WW
60672-1N	2" BSPP Inlet Thread	UU
60672-1P	2" NPT Inlet Thread	TT

The following option letters could be added to any of the above 60672-1 Units to result in a complete Dry Break Disconnect Assembly:

Option	Part Number	Description	Nozzle Option
B	41767-60	Adds 60-mesh Screen	B
C	41767-100	Adds 100-mesh Screen	C
E	43045-1	Adds Military Male Half to mate D-1 / D-2 Nozzles	N/A
J	43046	Adds Male Half Adapter to mate 60427 Nozzle	J

---

#### 4.0 SPECIAL TOOLS

The following special tools or their equivalent should be utilized to accomplish the overhaul and repair of the subject units:

- 6912-ST1 – Utilized to properly wind the two coil springs and install them in the check valve assembly.
  - 43113 ST1 – For use in assembling the check valve assembly into the housing.
- 

#### 5.0 DISASSEMBLY

- |   |   |
|---|---|
| <p>5.1. Remove Nozzle/Swivel Quick Disconnect from end of hose. Separate the Dry Break Quick Disconnect from the nozzle. Refer to SM60427 service manual for instructions on this operation.</p> <p>5.2. Remove Screws (12) and Washers (13) and set aside.</p> <p>5.3. Move Lock Ring (37) from the groove nearest to the Sleeve (14) to the one closest to the threaded end of the Housing (11).</p> <p>5.4. Retract Sleeve (14) toward Lock Ring (37). Grasp the Adapter Assy (1 or 31) and rotate and pull it free from the Housing Assembly. Remove the O-ring (4) and discard. Remove Seal (35).</p> <p>5.5. If a Screen (7) is present, it may be removed for replacement or cleaning by pulling it out of the unit. The O-ring (8) should be removed and discarded. This o-ring is only present to act as a retainer for the screen. The close fit of the screen with its housing, and the fact that the flow will keep the screen seated against a flat surface, will maintain a flow path area around and through the screen that will not be greater than directly through the screen.</p> <p>5.6. While holding the Sleeve (14) in the retracted position remove Retaining Ring (29). Use a small blade screwdriver or a sharp pointed instrument to lift one end of the Retaining Ring (29) free from its groove</p> | <p>and peel the Ring off of the Housing (11). Remove the Sleeve (14), Spring (15), and Balls (16).</p> <p>5.7. With a small blade screwdriver or sharp pointed instrument remove Ring (20) from its internal groove and peel it out. Grasp the Actuator (18) and simultaneously turn and pull it out of the Housing (11). Remove O-ring (30) from the internal groove and discard it. Remove Screw (17), Actuator (18), Spring (19) from Valve Assembly (21).</p> <p>5.8. Unless the special tools recommended in paragraph 4.0 are available, it is recommended that the Check Valve Assy (21) be replaced as a complete part number and that it not be disassembled further. Apply light finger pressure slightly off center and downward on top of Springs (23) &amp; (24). Using a 1/8" (3.18mm) diameter pin, push on Hinge Pin (22) until it protrudes approximately 3/4" (19 mm) out of opposite side. While maintaining finger pressure on Springs, remove Hinge Pin (22) by pulling on the protruding pin. Slowly release pressure from Springs (23) and (24) being careful not to allow Springs (23) and (24) to unwind rapidly. After Springs (23) and (24) have been removed, Check Valves (25) may be removed from Retainer (28). Care should be taken not to lose Spacers (26) and Washers (27) when removing Check Valves (25). Note orientation of the spacers and washers for proper reassembly later.</p> |
|---|---|
- 

#### 6.0 INSPECTION

- |   |   |
|---|---|
| <p>It is recommended that O-rings (4) &amp; (30) be replaced upon each overhaul of the Unit.</p> <p>6.1. Inspect all metal parts for dings, gouges, abrasions, etc. Use 320 grit paper to smooth and remove sharp edges. Replace any part with damage exceeding 15% of all wall thickness. Use alodine 1200 to touch up bared aluminum.</p> | <p>6.2. Inspect inside of Sleeve (14) for indications of brinelling, or ball indentations, at intersection of tapered surface, with constant inside diameter at ball lock area as well as for cracks, excessive abrasions, or other damage. Replace Sleeve if damaged or worn as described above.</p> <p>6.3. Inspect Housing (11) for cracks around the end opposite the threaded inlet at the</p> |
|---|---|

- retainer Ring (29) groove. Replace if evidence of cracking is present or excessive wear is apparent.
- 6.4. Inspect the rubber bonded seats of the Retainer (28) for nicks, voids, cracks or buildup of foreign material on the rubber seats. Inspect the Check Valves (25) for nicks or scratches on the sealing surfaces. Check Hinge Pin Hole areas for cracks or excessive wear.
- 6.5. Inspect the rubber bonded seals of the Seal (35) for nicks, voids, cracks or build-up of foreign material on the rubber seats. Place the Seal (35) onto a flat piece of glass to assure that the rubber seals have not taken a permanent set. A complete circle of rubber should make an impression on the glass. Replace if needed.

## 7.0 REASSEMBLY

Reassemble in reverse order of disassembly (Refer to Figure 1), observing the following:

- 7.1. Make certain all components are clean and free from oil, grease, or any other corrosion resistant compound on all interior or exterior surfaces. Wash all parts with cleaning solvent, Federal Specification P-D-680, and dry thoroughly with a clean, lint-free cloth or compressed air.

### WARNING:

Use cleaning solvent in a well-ventilated area. Avoid breathing of fumes and excessive solvent contact with skin. Keep away from open flame.

NOTE: A light coat of petrolatum, Federal Specification VV-P-236 or equivalent commercial quality, can be applied to all O-rings and screws for ease of installation.

- 7.1.1. Set Retainer (28) on a flat surface with the rubber seat side up. Lay both Check Valves (25) in the position shown in the exploded view. Apply a light coating of petroleum jelly to Spacers (26) and Washers (27) and carefully install in positions indicated with a pair of tweezers. Using installation tool 6912-ST1 (Figure 3, View A) place Springs (23) and (24) into tool base saddle with straight portion of end coil into slot in Base and under the pin at point "A" as shown in Figure 2. Insert mandrel shaft into inside diameter of one spring and rotate mandrel until screw in mandrel picks up end coil at point "B" in Figure 3. Continue rotating Mandrel in direction to tighten Spring coil winding Spring approximately 360° (one full turn). Transfer end coil from screw on Mandrel onto the screw head on the Base at point "C" in Figure 3. Repeat the coil winding operation with the second spring. With both Springs (23) and (24) installed and wound per the above, place the installation tool (saddle base less mandrel) (see Figure 3, View B) with springs (23) and (24) facing the Check Valves (25). Insert Hinge Pin (22) through holes on one side of Retainer (28). Align Spacers (26) and Washers (27) and holes in the hinge portion of the Check Valves (25). Push the Hinge Pin (22) through the aligned holes of details described above and the center of the coils of the Spring (23) and (24). With a thin blade screwdriver or a pointed instrument, lift the tangs of the Springs (23) and (24) closest to the outer edge of the Retainer (28) off the edge of the small screw holding the tangs in place on the installation tool. After the tangs have been lifted off the screws on the Tool, slide the installation tool off the tangs of the Springs (23) and (24) located at the center-line of the Check Valve Assembly (21).
- 7.1.2. Following assembly, the Check Valves (25) should be actuated manually to assure free movement with no evidence of binding. The check valves should contact the seat evenly on all surfaces.
- 7.1.3. Install new O-ring (30) into Housing (11) and lubricate with petroleum jelly. Install Check Valve Assembly (21) into Housing until it is fully seated. Lubricate the inside diameter of the hollow Sleeve from Installation Tool 43113-ST1 with petroleum jelly (refer to Figure 4). Insert this Sleeve fully into bore of the Housing. Insert Retainer Ring (20) into the open end of the Sleeve. Place the entire assembly into an arbor press and insert the small end of the Mandrel part (solid round part) of the Installation Tool into the Sleeve. Press Mandrel downward until Retainer Ring snaps into its groove. Remove Installation Tool. Check Valve Assembly (21) should be completely retained into Housing (11).
- 7.1.4. Lubricate threads on Screw (17) with petroleum jelly. Slide Actuator (18) over Screw. Slide Spring (19) over Screw. Then

- tighten Screw into thread of Check Valve Assembly (21) until it bottoms.
- 7.1.5. When installing the Sleeve (14), Spring (15) and Balls (16), it is recommended that the Balls be coated with petroleum jelly to retain them in the holes in the Housing (11).
- 7.1.6. The Lock Ring (37) should be installed in the groove closest to the Sleeve after the Adapter Assy (1 or 31) has been installed. This Ring is a secondary lock for the Sleeve.

## 8.0 TEST

- The Unit shall be tested as a part of a complete nozzle as instructed in SM60427 with the addition of the tests shown below.
- 8.1. Test Conditions  
Test media shall be Stoddard solvent (Federal Specification P-D-680), JP-4 per MIL-J-5624D at 75° ±15°F, Jet A or equivalent.
- 8.2. Function Test  
As mentioned above the Unit should be tested in accordance with Para 8.3 of SM60427. Disengage housing assembly from nozzle/adapter. Apply 60 psi pressure to the hose inlet and observe leakage from the outlet. There shall be no leakage from the outlet during a one minute observation period.

## 9.0 ILLUSTRATED PARTS CATALOG

The 60672-1 series of dry break disconnects consists of two sub-assemblies as shown in Figure 1, the appropriate female half and the male adapter half with its assembled parts. The female half can be procured as a separate subassembly as shown in Table 1.0. The male half is identical for all female halves.

**TABLE 1.0**

Inlet Thread	Female Assy Part Number	Inlet Thread	Female Assy Part Number
2" NPT	60672-1P	2-½" BSPP	60672-1K
2" BSPP	60672-1N	3" NPT	60672-1L
2-½" NPT	60672-1H	3" BSPP	60672-1M

Table 2.0 tabulates the parts and sub-assemblies comprising the 60672-1 series quick disconnect assembly and 41767 screen assemblies. The item numbers of the table are keyed to the exploded view of the disconnect diagramed in Figures 1 and 2.

**TABLE 2.0**

Item	Part Number	Description	Units Per Assy	Nozzle Option	Spares /10 Units/Yr.
1	43046	Male Half Adapter Assy	1	J	-
2	201201-231	O-ring	1	*	15
3	25079	Adapter	1	*	-
4	201201-151	O-ring	1	*	10
5	5710-63-30	Washer	6	*	-
6	GF16997-59	Screw	6	*	-
7	41767-60	Screen Assy – 60 Mesh	1	B	-
	41767-100	Screen Assy – 100 Mesh	1	C	-
8	201201-039	O-ring	1	*	10
9	80207-60	Screen	1	*	-
	80207-100	Screen	1	*	-
10	60672-1*	Female Half QD Assy	-	*	-

Item	Part Number	Description	Units Per Assy	Nozzle Option	Spares /10 Units/Yr.
11	203388-6	Housing, 2" NPT	1	TT	-
	203388-5	Housing, 2" BSPP	1	UU	-
	203388-1	Housing, 2 ½" NPT	1	XX	-
	203388-3	Housing, 3" NPT	1	VV	-
	203388-4	Housing, 3" BSPP	1	WW	-
12	GF35275-241	Screw	2	*	-
13	5712-36-063	Washer	2	*	-
14	203391-1	Sleeve, Retainer	1	*	-
15	203392	Spring, Return	1	*	-
16	GF19060-26	Ball	16	*	-
17	207604	Screw	1	*	-
18	201900	Actuator	1	*	1
19	203393	Spring, Actuator	1	*	-
20	RRT-287-S	Ring, Retainer	1	*	-
21	43173	Check Valve Assy	1	*	-
22	203390	Hinge Pin	1	*	-
23	23739-6	Spring	1	*	-
24	23739-5	Spring	1	*	-
25	201901	Check Valve	2	*	-
26	23741	Spacer	4	*	-
27	5710-21-10	Washer	2	*	-
28	43047	Retainer Assy	1	*	-
29	RS-354-S	Ring, Retainer	1	*	-
30	201201-233	O-Ring	1	*	10
31	43045-1	Military Male Half	1	*	-
32	203397	Adapter	1	*	-
33	GF960C516	Washer	6	*	-
34	GF35308-336	Bolt	6	*	-
35	MS27194-40	Seal	1	*	3
36	GF21083C5	Nut	6	*	-
37	203666	Ring, Lock	1	*	-

\* Refer to Table 1 for the correct complete part number of the Female Half QD Assy and paragraph 3.0 for appropriate nozzle option letter used to originally purchase this item. The 60672-1 family of dry break disconnects is no longer available. It is replaced by an appropriate 61154 Model. See your Eaton Carter brand distributor for ordering information.

- Notes:
1. All part numbers beginning with "GF" are interchangeable with those beginning with either "AN" or "MS". If the "GF" is followed by three numbers, it is interchangeable with an "AN" part, otherwise it is interchangeable with an "MS" part of the same number.
  2. The recommended spare parts shown above are the number required to support 10 Units for one year. The recommended quantities are based on the ration of spare parts sold for each unit during a one-year period of time. The actual quantity required will vary from location to location.

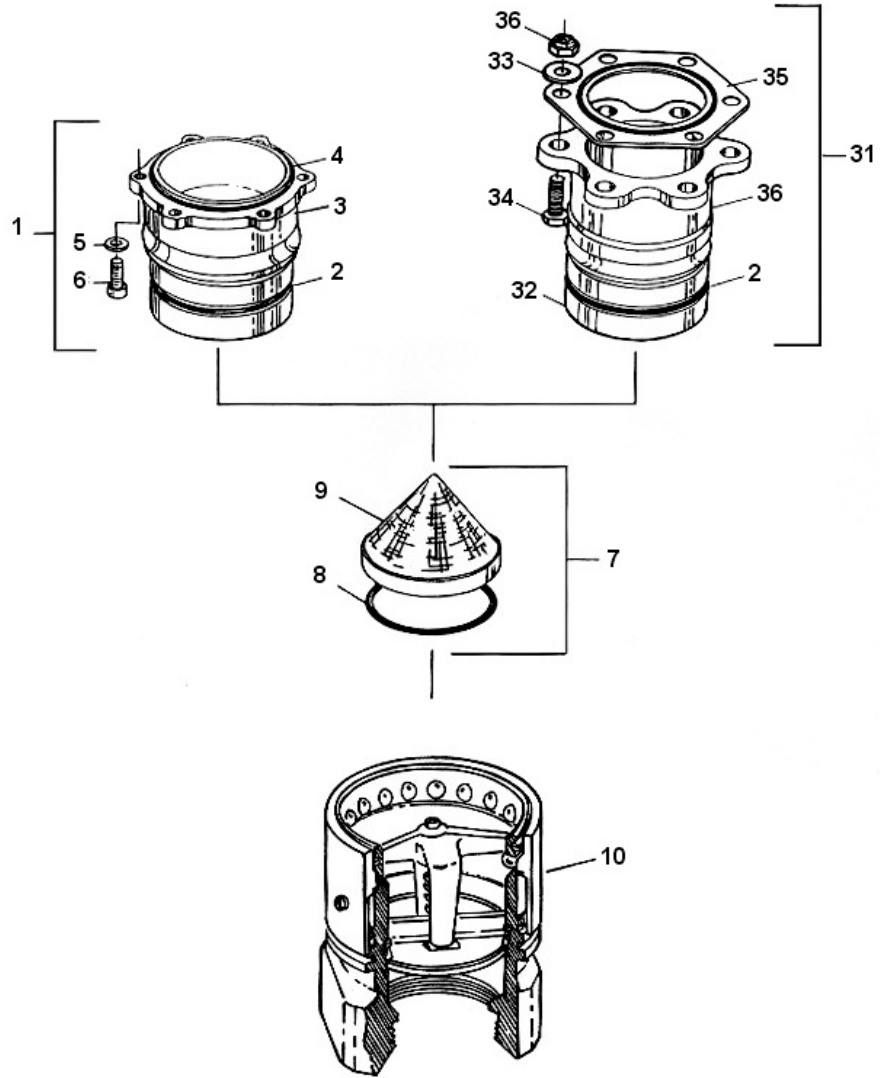

FIGURE 1



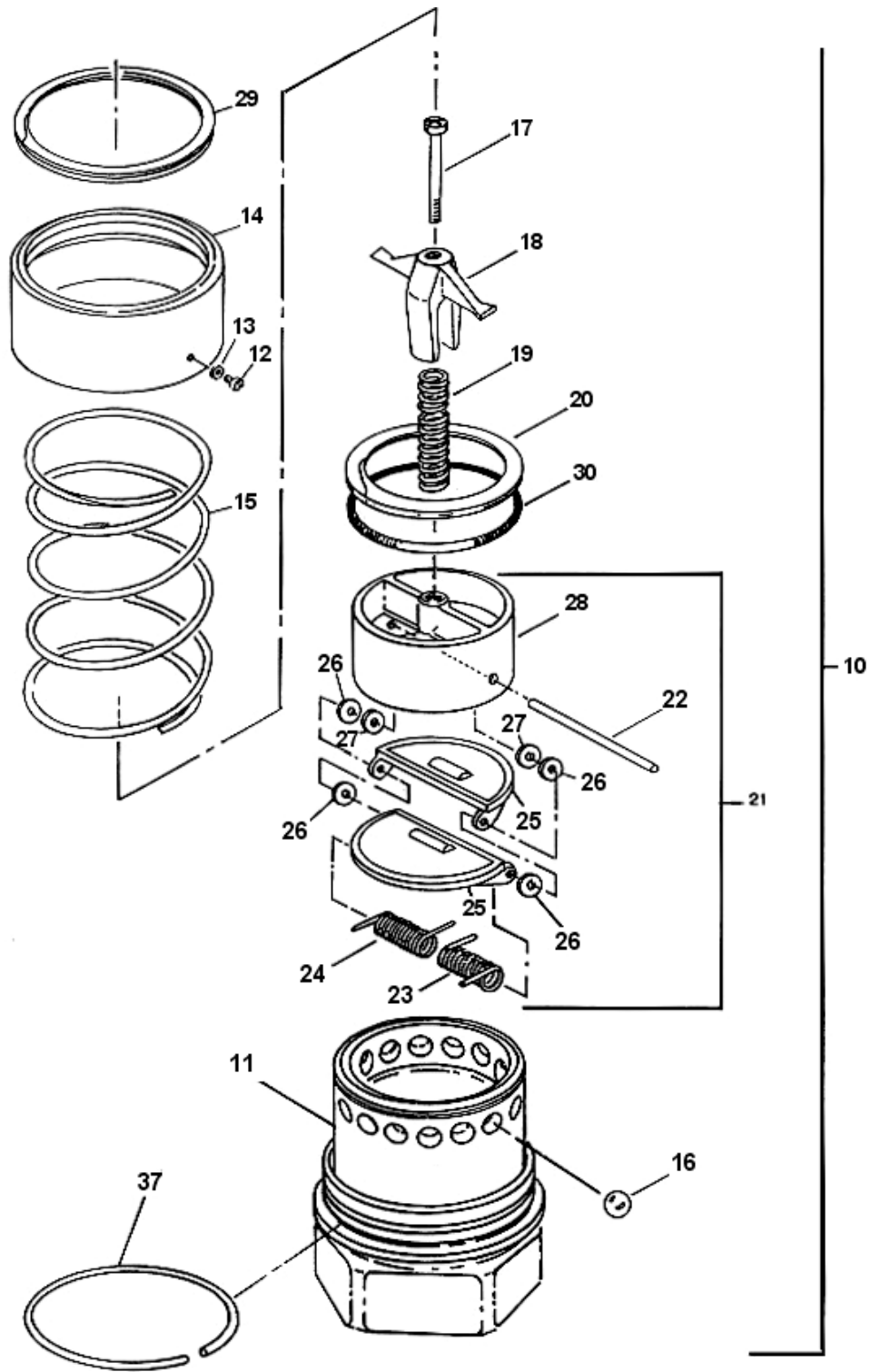
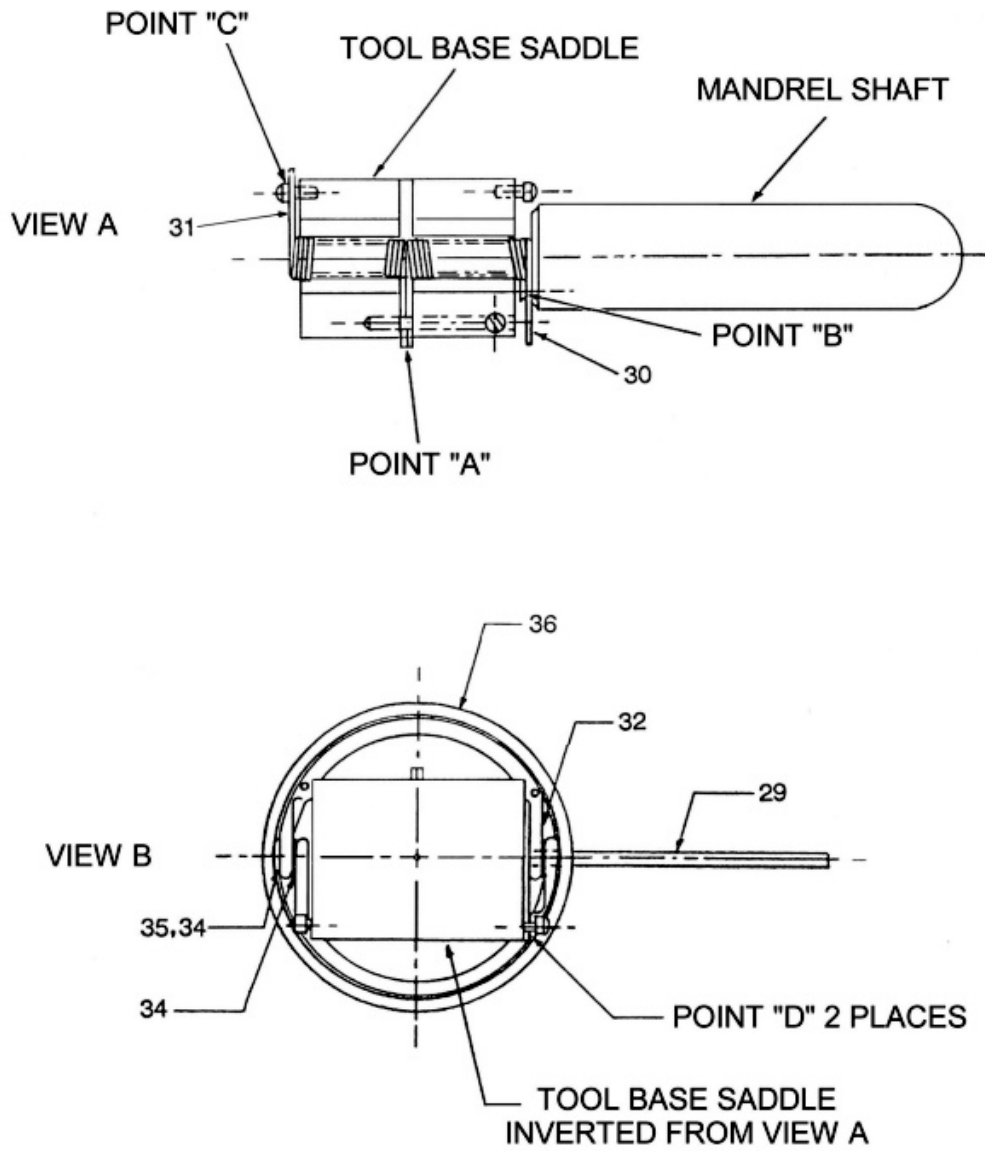
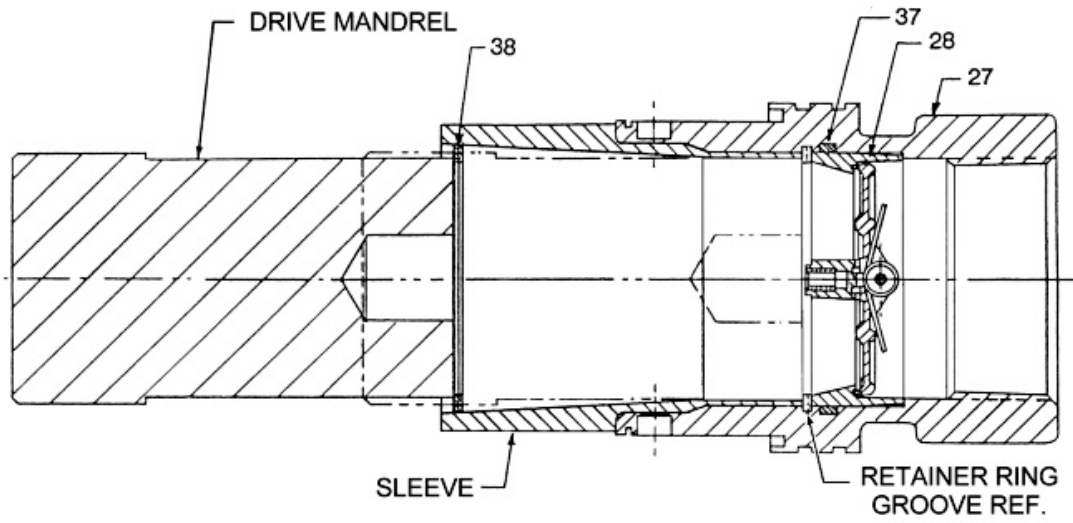

FIGURE 2



Installing Springs, 23 & 24, Using Tool 6912-ST1

**FIGURE 3**



Installation of Check Valve, item 21, using tool 43113-ST1

**FIGURE 4**

Aerospace Group  
Conveyance Systems Division  
9650 Jeronimo Road  
Irvine, California 92618  
Ph (949) 452-9500  
Fax (949) 452-9992



*Powering Business Worldwide*