



Powering Business Worldwide

Aerospace Group
Conveyance Systems Division
Carter® Brand Ground Fueling Equipment

SM64501

September 2008

Applicable addition manuals:
None

Maintenance & Repair Manual

**3" & 4" Air Operated Bypass
Pressure Control Valves**

Models 64501 & 64511

TABLE OF CONTENTS

	<u>PAGE</u>
1.0 Introduction	3
2.0 Equipment Description	3
3.0 Table of Options and Ordering Information.....	3
4.0 Disassembly	3
5.0 Inspection	6
6.0 Reassembly	6
7.0 Test	9
8.0 Illustrated Parts Catalog.....	9
Figure 1 - Air Operated Bypass Valve	11
Figure 2 - Manifold Assembly.....	13
Figure 3 - 3 Inch Valve Assembly	15
Figure 4 - 4 Inch Valve Assembly	17
Figure 5A - Inner Piston Seal Installation - Older Units	18
Figure 5B- Inner Piston Seal Installation - Newer Units.....	18
Figure 6 - Outer Piston Seal Installation	18

NOTE: The information in this manual is to the latest revision of the products listed above at the time of this printing. Eaton reserves the right to change this manual at its discretion.

**Maintenance, Overhaul & Test Instructions
Eaton's Carter Brand Models 64501 & 64511 3 Inch & 4 Inch Air Operated
Bypass Pressure Control Valves**

1.0 INTRODUCTION

This manual furnishes detailed instructions covering the maintenance and overhaul of Carter brand Model 64501, 3 inch and Model 64511, 4 inch

Air Operated Bypass Pressure Control Valves and the various options listed in Section 3.0.

2.0 EQUIPMENT DESCRIPTION

Carter Models 64501 and 64511 are the latest versions of the 3 inch & 4 inch Air Reference Bypass Pressure Control Valves that replace the older 64082 and 64002 models. Because they have many characteristics in common, a single manual is used to present both units.

The valves listed above are intended to be installed to bypass the pump and hence are designed to provide a constant nominal pressure at a remote sense point as a function of reference AIR pressure. They accomplish this by "bypassing" the necessary flow around the pump to control the pressure. The valves are direct operating spring loaded piston type valves. When reference AIR pressure is applied to the proper port on the manifold the fuel pressure will increase.

If the valves are to be used at a flow below approximately 100 gpm the reference pressure

may have to be increased to obtain the desired fuel pressure. The reference pressure may vary slightly from unit to unit. Changing the reference pressure is the only way of adjusting fuel discharge pressure. This is easily accomplished directly on the manifold by using the adjustment knob.

A minimum line size 3/8 inches should be used as a fuel sense line. Stainless tubing for this line is recommended. If two venturis are used, a three-way valve with at least a 1/4-inch internal orifice should be used to obtain proper surge control.

The bleeder on the manifold allows bleeding of air from the fuel sense line. The valve should be installed with the bleeder in the upward position to facilitate proper bleeding.

3.0 TABLE OF OPTIONS AND ORDERING INFORMATION

The 64501 and 64511 have common options as listed below.

Carter recommends that at least one end of the valve be flange mounted to the

pipng system, if both inlet and outlet are Victaulic connections proper bracing must be provided.

Options to be added to Models 64501 or 64511 Air Operated Bypass Pressure Control Valves:

OPTION LETTER	DESCRIPTION	OPTION LETTER	DESCRIPTION
D	Adds one Victaulic Adapter Assembly for use on either the inlet or outlet of the unit. (The parts are shipped as loose parts to be used on either end). Mounting fasteners are not provided.	E	Adds two Victaulic Adapter Assemblies for use both the inlet and outlet of the unit. (The parts are shipped as loose parts to be used on either end). Mounting fasteners are not provided.
		F	Adds Relief Valve Cap

Example: 64501D – Basic 3" Air Operated Pressure Control Valve with a kit of parts to convert the standard ASA flange on either end to mate a Victaulic fitting.

64501E - Basic 3" Air Operated Pressure Control Valve with a kit of parts to convert the standard ASA flange both ends to mate Victaulic fittings.

4.0 DISASSEMBLY

4.1 64501 & 64511 Valves – Note that due to the similarity between the units, this manual covers both units. The appropriate part numbers for the same type of part are noted Section 8.0.

Refer to Figure 1 for this operation. The valve consists of two basic items, the Valve Assembly (1-1) and the Manifold Assembly (1-2). If a Victaulic fitting is present on the outlet of the

- valve assembly remove it. Discard the O-ring (from a Carter furnished fitting) or the gasket that is used to seal the fitting to the valve.
- 4.2 MANIFOLD ASSEMBLY - Refer to Figure 2. Remove the Manifold Assembly (1-2) from the unit by removing Screw (2-15) and pulling the manifold from the unit being careful to not lose any of the four (4) Retainers (2-13). Discard O-rings (2-14) when removed.
- Note:** Repairs to the Manifold Assembly (1-2) can be accomplished without removing the main valve from the vehicle system. Be sure that the pressure is relieved before doing this.
- 4.2.1 Remove Housing Check Valve (2-6) and then remove all of the internal parts contained by it. Remove and discard O-rings (2-4) and (2-5).
- 4.2.2 Do not remove Bleeder Assembly (2-12) unless it is to be replaced due to leakage from its threaded fastener or from the bleeder valve itself. If it is removed then it can be disassembled by removing the Retainer Ring (2-12F) with the proper pliers and all other parts will then come out.
- 4.2.3 Use a spanner to remove Cylinder (2-18) to allow access to the parts retained by it. Remove and discard O-rings (2-17) and (2-22). Once the cylinder is removed, the parts retained by it will be accessible. Pull the Piston Assembly (2-19) from the cylinder. Do not try to remove the pin from the center of the piston assembly, it is press fitted in place. Remove and discard Seal (2-20). If necessary, use either long-nosed pliers or a brass pick to remove the Spacer (2-21). If a brass probe is used probe into the hole in the Spacer (2-21) to find the cross hole in the Valve Stem (2-25). The hole is about a half inch down from the top of the spacer concealed by the Cage (2-24). Pull the parts out with the pick. Remove and discard O-rings (2-14), (2-23), (2-26) and (2-27). Ensure Spring (2-28) is removed with the rest of the parts.
- 4.2.4 Remove Screw (all five) (2-8) and O-rings (2-7) and discard the O-rings.
- 4.2.5 Do not remove the Relief Valve (2-9) unless there is a problem with it. Then, if the Relief Valve (2-9) is lock wired to Screw (2-16) and it needs servicing, cut the wire. Do not remove Screw (2-16) it is used only to safety the relief valve to prevent tampering. Remove and discard the entire assembly.
- 4.2.6 It is not necessary to remove Orifice (2-10).
- 4.3 3" VALVE ASSEMBLY – Refer to Figure 3 for this operation.
- 4.3.1 Rotate Outer Piston (3-25) to access 4 Screws (3-5) these screws are a self locking type screws that utilize a nylon insert in the threads to affect resistance and keep the screw locked in place. They can be reused a number of times before

losing their locking ability. Using a torque wrench, remove the screws. If the torque is less than 2 inch lbs. replace during reassembly.

- 4.3.2 Discard O-Rings (3-8).
- 4.3.3 Grasp Outer Piston (3-25) and remove the entire piston/shaft assembly from the outlet of the valve.
- 4.3.4 Remove and discard O-rings (3-7) and (3-6) from the shoulder and groove of the Piston Retainer (3-21).

WARNING:

Before proceeding further beware that the outer piston and attaching parts are heavily spring loaded and a vise or similar should be used to safely disassemble the piston assembly.

- 4.3.5 As indicated above, a vise or woodworkers clamp is required to proceed further. Wood blocks should be used to secure the piston

Assemble such that an axial load is exerted yet allows access to both Nuts (3-16).

NOTE:

Shaft (3-27) and nut (3-16) are both stainless steel. Nut (3-16) also includes a locking element. Due to this combination there is the possibility when these items are disassembled that the threads may gall or become damaged beyond repair. If it is necessary to disassemble these items replace both nuts (3-16) and consider replacing the shaft (3-27).

CAUTION:

Be certain the piston assembly is securely held in place and cannot slip, allowing the unit to forcibly separate when the first nut (3-16) is removed. Forcible separation may cause personal injury. Be careful not to damage the sealing surface of the inner or outer piston.

- 4.3.6 With the assembly securely clamped in place, carefully remove Nut (3-16) from the piston assembly, use Lockease or similar as an aid in removing the nut. Remove Washer (3-17) from piston assembly. Slowly open the clamping device allowing the spring force to cause the inner piston assembly to follow the clamp until all spring force is relieved. Then carefully remove the clamp and lift the Inner Piston (3-20) from the Spring (3-26). Remove the two bronze Washers (3-29) from the Inner Piston (3-20) then remove Spring (3-26) and Teflon Washer (3-30) from the Guide (3-22). Remove O-ring (3-18) and Washer (3-19) from the end of Shaft (3-27). Discard O-ring (3-18).

- 4.3.7 Using two thin 3/8-24 UNF-2B nuts as jam nuts on the shaft (3-27) where Nut (3-16) was removed above, remove Nut (3-16) and Washer (3-17) retaining the outer Piston (3-25) from the Shaft (3-27).
- 4.3.8 Remove Screws (3-28) from the spring Guide (3-22) to remove Seal (3-23) and O-ring (3-24) from retainer. Discard O-ring (3-24).
- 4.3.9 On older versions of the 3" valve, it will be necessary to remove Screws (3-12) and remove Seal Housing (3-11) from Body (3-1). Remove and discard O-ring (3-13).
- 4.3.10 Remove and discard Seal (3-10) and O-ring (3-9).
- 4.3.11 Remove Screws (3-14) and then pull out Seal Housing Retainer (3-4) and Housing (3-15) with Seals (3-2) and O-rings (3-3). Discard Seals (3-2) and O-rings (3-3).
- Note: It is recommended the user upgrade to the new seal cartridge. The new design with the energized Seal (3-2) and O-Ring (3-3) are included in the overhaul kit KD64500-5. These seals will not work with the old-style cartridge. Request a -8 kit for hardware items (3-4 & 3-15) to complete the upgrade. This configuration provides a more robust seal, reducing leakage and frequency for overhaul of the seal cartridge.**
- 4.3.12 Older Units Seal Cartridge: Remove Screws (3-14) and then pull out Seal Housing (3-4A). Then remove and discard Seals (3-15A) and O-rings (3-2A) and (3-3).
- 4.3.13 Newer versions are equipped with a Set-Screw (3-36). It is not necessary to remove this screw.
- 4.4 4" VALVE ASSEMBLY – Refer to Figure 4 for this operation.
- 4.4.1 Rotate Outer Piston (4-25) to access 4 Screws (4-5) these screws are a self locking type screws that utilize a nylon insert in the threads to affect resistance and keep the screw locked in place. They can be reused a number of times before losing their locking ability. Using a torque wrench, remove the screws. If the torque is less than 2 inch lbs. replace during reassembly. Remove the four Screws (4-5) and Washers (4-8).
- 4.4.2 Grasp Outer Piston (4-25) and remove the entire piston/shaft assembly from the outlet of the valve.
- 4.4.3 Remove and discard O-rings (4-7) and (4-6) from the shoulder and groove of the Piston Retainer (4-21).

WARNING:

Before proceeding further beware that the outer piston and attaching parts are heavily spring loaded and a vise or similar should be used to safely disassemble the piston assembly.

- 4.4.4 As indicated above, a vise or woodworkers clamp is required to proceed further. Wood blocks should be used to secure the piston.

Assemble such that an axial load is exerted yet allows access to both Nuts (4-16).

NOTE:

Shaft (4-27) and nut (4-16) are both stainless steel. Nut (4-16) also includes a locking element. Due to this combination there is the possibility when these items are disassembled that the threads may gall or become damaged beyond repair. If it is necessary to disassemble these items replace both nuts (4-16) and consider replacing the shaft (4-27).

CAUTION:

Be certain the piston assembly is securely held in place and cannot slip, allowing the unit to forcibly separate when the first nut (4-16) is removed. Forcible separation may cause personal injury. Be careful not to damage the sealing surface of the inner or outer piston.

- 4.4.5 With the assembly securely clamped in place, carefully remove Nut (4-16) from the piston assembly, use Lockease or similar as an aid in removing the nut. Remove Washer (4-17) from piston assembly. Slowly open the clamping device allowing the spring force to cause the inner piston assembly to follow the clamp until all spring force is relieved. Then carefully remove the clamp and lift the Inner Piston (4-20) from the Spring (4-26). Remove the two bronze Washers (4-29) from the Inner Piston (4-20) then remove Spring (4-26) and Teflon Washer (4-30) from the Guide (4-22). Remove O-ring (4-18) and Washer (4-19) from the end of Shaft (4-27). Discard O-ring (4-18).
- 4.4.6 Using two thin 3/8-24 UNF-2B nuts as jam nuts on the shaft (4-27) where Nut (4-16) was removed above, remove Nut (4-16) and Washer (4-17) retaining the outer Piston (4-25) from the Shaft (4-27).
- 4.4.7 Remove Screws (4-28) from the spring Guide (4-22) to remove Seal (4-23) and O-ring (4-24) from retainer. Discard O-ring (4-24).
- 4.4.8 Remove and discard Seal (4-10) and O-ring (4-9).
- 4.4.9 Remove Screws (4-14) and then pull out Seal Housing Retainer (4-4) and Housing (4-15)

with Seals (4-2) and O-rings (4-3). Discard seals (4-2) and O-rings (4-3).

Note: It is recommended the user upgrade to the new seal cartridge. The new design with the energized Seal (4-2) and O-Ring (4-3) are included in the overhaul kit KD64500-6. These seals will not work with the old-style cartridge. Request a -8 kit for hardware items (4-4 & 4-15) to complete the upgrade. This configuration provides a more robust seal, reducing leakage and

frequency for overhaul of the seal cartridge.

- 4.4.10 Older Units Seal Cartridge: Remove Screws (4-14) and then pull out Seal Housing (4-4A). Then remove and discard Seals (4-15A) and O-rings (4-2A) and (4-3).
- 4.4.11 Newer versions are equipped with a Set-Screw (4-36). It is not necessary to remove this screw.

5.0 INSPECTION

It is recommended that all O-rings and seals be replaced at every overhaul. Inspect all metal parts for dings, gouges, abrasions, etc. On the inner and outer piston use 320 grit paper to remove any sharp edges if required be careful not to remove the hard anodize finish on these pistons. Check the knife-edge of the outer piston where it meets O-ring (3-7 or 4-7) This edge should be smooth and free of any imperfections. If any imperfections are found that cannot be polished from the

surfaces or the knife-edge the part should be replaced.

Inspect all metal parts for dings, gouges, abrasions, etc. Use 320 grit paper to smooth and remove sharp edges. Replace any part with damage exceeding 15% of local wall thickness. Use alodine 1200 to touch up bared aluminum.

Note: Nuts (3-16) & (4-16) should not be reused.

6.0 REASSEMBLY

Reassembly is accomplished in essentially the reverse order of disassembly. A light coat of petroleum jelly may be used during overhaul but do not use any other type of lubricant, **ONLY PETROLEUM JELLY.**

assembly into the main Housing (3-1) with the "notch" on (3-4A) oriented as shown on Figure 3.

- 6.1.2 Install Screws (3-14) and torque to 18 ± 2 in.-lb. (21 ± 2 kg-cm). Condition seals with seal run-in tool AF42208-1 [use instructions from the SM64800 manual.]

Note: Lightly lubricate all O-rings except O-Ring (3-9) or (4-9) and O-Ring (3-2A) or (4-2A) [old seal cartridge design] to be installed dry).

Note: It is recommended the user upgrade to the new seal cartridge. The new design with the energized Seal (3-2) and O-Ring (3-3) are included in the overhaul kit KD64500-5. These seals will not work with the old-style cartridge. Request a -8 kit for hardware items (3-4 & 3-15) to complete the upgrade. This configuration provides a more robust seal, reducing leakage and frequency for overhaul of the seal cartridge.

- 6.1 Make certain all components are clean and free from oil, grease, or any other corrosion resistant compound on all interior or exterior surfaces. Wash all parts with cleaning solvent, Federal Specification P-D-680, and dry thoroughly with a clean, lint-free cloth or compressed air.

WARNING:
Use cleaning solvent in a well-ventilated area. Avoid breathing of fumes and excessive solvent contact with skin. Keep away from open flame.

- 6.2 3" VALVE ASSEMBLY- Refer to Figure 3 for this operation.

- 6.2.3 Seal Cartridge newer units: O-rings (3-3) should be fitted onto the grooves of Seal Housing (3-15). The lubricated Inner Piston Seals (3-2) should be installed on the inside diameter of the Seal Housing (3-15) per Figure 5B. Now insert the assembly into the main Housing (3-1) with the "notch" on (3-4) oriented as shown on Figure 3. Be careful not to damage the seals during installation.

- 6.2.1 Seal Cartridge older units: Place O-rings (3-3) into the grooves of the Seal Housing (3-4A) outside diameter. Install O-rings (3-2A) in O-ring grooves on inside diameter of Housing. DO NOT LUBRICATE. Next install Piston Seals (3-15A) in inside diameter grooves over O-rings (3-2A) per Figure 5A. Smooth the combination of the Seal and O-ring (3-2A) with the finger to assure that they are installed completely in the seal grooves. Apply a light coat of lube and then insert the

- 6.2.4 Install the Seal Housing Retainer (3-4) into the main Housing (3-1) by installing Screws (3-14). Torque Screws (3-4) to 18 ± 2 in.-lb. (21 ± 2 kg-cm). When properly installed, it is not necessary to polish the new type seals.

NOTE:

Shaft (3-27) and nut (3-16) are both stainless steel. Nut (3-16) also includes a locking element. Due to this combination there is the possibility when these items are disassembled that the threads may gall or become damaged beyond repair. If it is necessary to disassemble these items replace both nuts (3-16) and consider replacing the shaft (3-27).

- 6.3 Assemble Outer Piston (3-25) onto Shaft (3-27) using Washer (3-17) and Nut (3-16). Use two thin nuts 3/8-24 UNF-2B nuts as jam nuts on the opposite end of the Shaft (3-27) and tighten the Nut (3-16) 195 ± 10 in.-lb. (225 ± 12 kg-cm).
- 6.3.1 Install O-ring (3-24) on Seal (3-23) and install in Retainer (3-21). The leg or hook end of the seal should point toward the Outer Piston (3-25). Press the seal into place very carefully in the retainer. Install Screws (3-28) through spring Guide (3-22) and tighten screws equally.
- 6.3.2 Apply a light coat of lube to inside ID of Seal (3-23) and slide the Retainer (3-21) onto Shaft (3-27).
- 6.3.3 Install Teflon Washer (3-30) on the shoulder of the spring Guide (3-22).
- 6.3.4 Place Washer (3-19) over the end of the Shaft (3-27) and install O-ring (3-18) above the washer.
- 6.3.5 Install Spring (3-26) onto Guide (3-22). Place the two bronze Washers (3-29) on top of the spring and hold them in place by placing the Inner Piston (3-20) over Spring (3-26). Insert assembly into the clamping device used during disassembly. Compress the assembly and allow access to install the Washer (3-17) and Nut (3-16) on the end of the shaft and tighten to 195 ± 10 in.-lb. (225 ± 12 kg-cm).
- 6.3.6 Install the O-ring (3-6) into groove in Retainer (3-21). Install O-ring (3-7) over the end of the Retainer (3-21) to where it rests against the retainer's shoulder.
- 6.3.7 Insert the non-lubricated O-ring (3-9) into the groove in the outlet of Housing (3-1) Install Seal (3-10) over O-ring (3-9) (Refer to Figure 6).
- 6.3.8 On older versions, if equipped, place O-ring (3-13) over Retainer (3-11) and install the assembly into the main housing fully without cutting the O-ring (3-13). Rotate the retainer to line up the four holes with the mating holes in the housing and install Screws (3-12).
- 6.3.9 Insert piston assembly into the housing and rotate Outer Piston (3-25) to line up the four holes with the mating holes in the housing. Place O-rings (3-8) over Screws (3-5) and tighten in a cross manner.
- 6.3.10 On newer units with a Set-Screw (3-36) ensure the screw has not become loose and remains snug in the housing.

- 6.4 4" VALVE ASSEMBLY - Refer to Figure 4 for this operation.
- 6.4.1 Seal Cartridge older units: Place O-rings (4-3) into the grooves of the Seal Housing (4-4A) outside diameter. Install O-rings (4-2A) in O-ring grooves on inside diameter of Housing. DO NOT LUBRICATE. Next install Piston Seals (4-15A) in inside diameter grooves over O-rings (4-2A) per Figure 5A. Smooth the combination of the Seal and O-ring (4-2A) with the finger to assure that they are installed completely in the seal grooves. Apply a light coat of lube and then insert the assembly into the main Housing (3-1) with the "notch" on (4-4A) oriented as shown on Figure 3.
- 6.4.2 Install Screws (4-14) and torque to 18 ± 2 in.-lb. (21 ± 2 kg-cm). Condition seals with seal run-in tool AF42208-1 [use instructions from the SM64800 manual.]
- Note: It is recommended the user upgrade to the new seal cartridge. The new design with the energized Seal (4-2) and O-Ring (4-3) are included in the overhaul kit KD64500-6. These seals will not work with the old-style cartridge. Request a -8 kit for hardware items (4-4 & 4-15) to complete the upgrade. This configuration provides a more robust seal, reducing leakage and frequency for overhaul of the seal cartridge.**
- 6.4.3 Seal Cartridge newer units: O-rings (4-3) should be fitted onto the grooves of Seal Housing (4-15). The lubricated Inner Piston Seals (4-2) should be installed on the inside diameter of the Seal Housing (4-15) per Figure 5B. Now insert the assembly into the main Housing (4-1) with the "notch" on (4-4) oriented as shown on Figure 3. Be careful not to damage the seals during installation.
- 6.4.4 Install the Seal Housing Retainer (4-4) into the main Housing (4-1) by installing Screws (4-14). Torque Screws (4-4) to 18 ± 2 in.-lb. (21 ± 2 kg-cm). When properly installed, it is not necessary to polish the new type seals.

NOTE:

Shaft (4-27) and nut (4-16) are both stainless steel. Nut (4-16) also includes a locking element. Due to this combination there is the possibility when these items are disassembled that the threads may gall or become damaged beyond repair. If it is necessary to disassemble these items replace both nuts (4-16) and consider replacing the shaft (4-27).

- 6.4.5 Assemble Outer Piston (4-25) onto Shaft (4-27) using Washer (4-17) and Nut (4-16). Use two thin nuts 3/8-24 UNF-2B nuts as jam nuts on the opposite end of the Shaft (4-27) and tighten the Nut (4-16) 195 ± 10 in.-lb. (225 ± 12 kg-cm).

- 6.4.6 Install O-ring (4-24) on Seal (4-23) and install in Retainer (4-21). The leg or hook end of the seal should point toward the Outer Piston (4-25). Press the seal into place very carefully in the retainer. Install Screws (4-28) through spring Guide (4-22) and tighten screws equally.
- 6.4.7 Apply a light coat of lube to inside ID of Seal (4-23) and slide the Retainer (4-21) onto Shaft (4-27).
- 6.4.8 Install Teflon Washer (4-30) on the shoulder of the spring Guide (4-22).
- 6.4.9 Place Washer (4-19) over the end of the Shaft (4-27) and install O-ring (4-18) above the washer.
- 6.4.10 Install Spring (4-26) onto Guide (4-22). Place the two bronze Washers (4-29) on top of the spring and hold them in place by placing the Inner Piston (4-20) over Spring (4-26). Insert assembly into the clamping device used during disassembly. Compress the assembly and allow access to install the Washer (4-17) and Nut (4-16) on the end of the shaft and tighten to 195 ± 10 in.-lb. (225 ± 12 kg-cm).
- 6.4.11 Install the O-ring (4-6) into groove in Retainer (4-21). Install O-ring (4-7) over the end of the Retainer (4-21) to where it rests against the retainer's shoulder.
- 6.4.12 Insert the non-lubricated O-ring (4-9) into the groove in the outlet of Housing (4-1) Install Seal (4-10) over O-ring (4-9) (Refer to Figure 6).
- 6.4.13 Insert piston assembly into the housing and rotate Outer Piston (4-25) to line up the four holes with the mating holes in the housing. Place Washers (4-8) over Screws (4-5) and tighten in a cross manner.
- 6.4.14 On newer units with a Set-Screw (4-36) ensure the screw has not become loose and remains snug in the housing.
- 6.5 MANIFOLD ASSEMBLY
- 6.5.1 Assemble in the reverse order.
- 6.5.2 If for any reason Orifice Screw (2-10) was removed, reinstall at this time.
- 6.5.3 If the Relief Valve (2-9) was removed then install a new one. After the Relief Valve has been adjusted, during flow testing, safety wire the valve to the Screw (2-16) to prevent tampering.
- 6.5.4 Replace all five of Screws (2-8) and O-rings (2-7).
- 6.5.5 First drop Spring (2-28) into the cavity where the cylinder is to go. Placing O-ring (2-27) onto

Valve Stem (2-25) being sure it is well lubricated. Then place O-rings (2-14) and (2-26) onto Cage (2-24) and insert the valve stem into it. Be sure to lubricate the O-rings well with petroleum jelly. Press this sub-assembly firmly in place in the cavity and seat it in place. Install a lubricated O-ring (2-23) into the groove on top of the Cage (2-24). Then install the Spacer (2-21) with the recessed side inward toward the cage assembly. Lube and install the O-ring (2-22) into the groove in the cavity.

- 6.5.6 Place a lubricated Cup Seal (2-20) in the groove in the Piston Assembly (2-19) being sure that the open end of the seal is facing away from the pin end of the piston assembly. Carefully insert the piston assembly into the Cylinder (2-18). After placing a lubricated O-ring (2-17) onto the groove in the large end of the cylinder insert it and secure tightly with a spanner.
- 6.5.7 If bleed valve was disassembled begin by placing O-ring (2-12C) over the Poppet (12B). Lay Plug (2-12A) upside down and insert assembled (2-12B) [Reference Figure 2]. Place Spring (2-12D) over the shaft of Poppet (2-12B). Place the Washer (2-12E) on the Spring (2-12D). Compress assembled unit thus far and use snap or lock ring pliers to separate the Retainer (2-12F) and install in the retainer groove on the inside diameter of the bleeder Plug (2-12A).
- 6.5.8 Use a product similar to Vibra Seal (2-11) on the pipe threads on item (2-12) and install Bleeder Assembly (2-12) in bleeder port of manifold.

NOTE:

Do not use Teflon tape on any threads in this product. Loose pieces of tape can cause failure of the product.

- 6.5.9 If check valve was disassembled begin by placing Spring (2-2) into the cavity marked "fuel". Next, place O-ring (2-5) over the top of the Check Valve (2-3) and place over the spring. Install Gasket (2-4) onto the Check Valve Housing (2-6) and install in the fuel port of the manifold.
- 6.5.10 Be careful to install Retainers (2-13) and O-rings (2-14) in the proper places. One may use a coating of petroleum jelly to hold them in place while assembling the manifold to the main valve.
- 6.5.11 Place the manifold assembly onto the valve and retain with Screw (2-15) tightening to hold securely in place.

7.0 TEST

7.1 The following test procedures will be accomplished after overhaul:

7.2 TEST CONDITIONS

Test media shall be JP-8 MIL-T-83133, Jet A, an odorless kerosene or Stoddard type solvent MIL-PRF-7024E Type II.

BLEEDING VALVE!
Before testing or use the valve must be bled of all trapped air. After pressurizing the unit use a plastic rod to depress Poppet (2-12B) with a rag around the unit to absorb fuel flow from the bleeder. This should be done long enough to assure all trapped air is exhausted from the valve.

7.3 VALVE BODY AIR-TIGHTNESS TEST

Note that the various ports noted below are identified by engraved markings, "AIR", "FUEL" and "BLEED".

7.3.1 Plug the inlet of the valve. Fully close the Pump Pressure Adjustment knob by fully turning clockwise.

7.3.2 Apply 40-psig air pressure to the air reference port and 85-psig air pressure to the fuel sensing port so that the valve is in the full open condition. Position the valve such that the outlet faces upward. Fill the valve outlet with test fluid and maintain air pressure for one minute. Visually check for air leakage into the

fuel path by observing air bubble formation. There should be no air leakage.

7.3.3 Release internal pressure and drain the test fluid.

7.3.4 Connect a 0-300-psig test fluid source to the valve inlet and outlet. Connect the valve outlet to a fitting equipped with a shutoff valve.

7.3.5 Slowly increase fuel pressure to the valve inlet to open the piston. Fill the valve from the inlet with test fluid while bleeding all air from the valve through the outlet valve. Keep the valve outlet at the highest point while bleeding.

7.3.6 When the test setup is full and bled, pressurize the valve inlet and outlet simultaneously with the test fluid pressure at 125 psi and maintain for one minute while visually inspecting the valve for indication of external leakage. There shall be none.

7.3.7 Reduce the test pressure to 4-6-psig and maintain for one minute while visually inspecting for external leakage. There shall be none.

7.3.8 Release internal pressure and drain the test fluid.

7.4 FUNCTIONAL TEST

Testing for functionality can be accomplished on the vehicle unless there is a complete test rig available. If there is, contact Carter for more details on how to test for full function.

8.0 ILLUSTRATED PARTS CATALOG

Tables 1.0 – 4.0 tabulate the parts and sub-assemblies comprising the 64501 & 64511 Air Operated Bypass Pressure Control Valves.

The item numbers of the table are keyed to the exploded views of the valve diagrammed in Figures 1 - 4.

TABLE 1.0
Reference Figure 1

Fig.	Item	Part Number	Description	Units/ Assy	Used On	Spares/10 Units/Yr
1	1	47510-2	Valve Assembly – 3" Bypass	1	64501	-
		47511-2	Valve Assembly – 4" Bypass	1	64511	-
	2	47501	Manifold Assembly	1	64501 & 64511	-
	3	47512	Victaulic Adapter Assembly – 3" Valves	1 or 2	64501D or E	-
	4	221596	Victaulic/ANSI Flange Adapter – 3"	1	47512	-
	5	MS29513-245	O-ring	1	47512	10
	3	47513	Victaulic Adapter Assembly – 4" Valves	1 or 2	64511D or E	-
	4	221597	Victaulic/ANSI Flange Adapter – 4"	1	47513	-
	5	MS29513-255	O-ring	1	47513	10

Kits to overhaul the main valve assembly and the manifold are available (see below). If the entire valve is to be overhauled, a minimum of two kits will be required, one for the main valve and one for the manifold assembly.

- KD64500-1 Kit - Contains the parts needed to overhaul the above manifold assembly – contains items: 2-4, 2-5, 2-7, 2-12C, 2-14, 2-17, 2-20, 2-22, 2-23, 2-26 & 2-27.
- KD64500-5 Kit – Contains the parts needed to overhaul the 47510-2 3" valve assembly – contains items: 3-2, 3-3, 3-6, 3-7, 3-8, 3-9, 3-10, 3-13, 3-18, 3-23 & 3-24.
- KD64500-6 Kit – Contains the parts needed to overhaul the 47511-2 4" valve assembly – contains items: 4-2, 4-3, 4-6, 4-7, 4-9, 4-10, 4-18, 4-23 & 4-24.
- KD64500-7 Kit – Contains the interface o-rings used on the Victaulic Adapters option D or E - contains items: 1-5 for both 3" and 4" adapters.
- KD64500-8 Kit – Contains the housing and retainer necessary to upgrade to the now standard seal cartridge design - contains items: 3-4 and 3-15 (or 4-4 and 4-15).

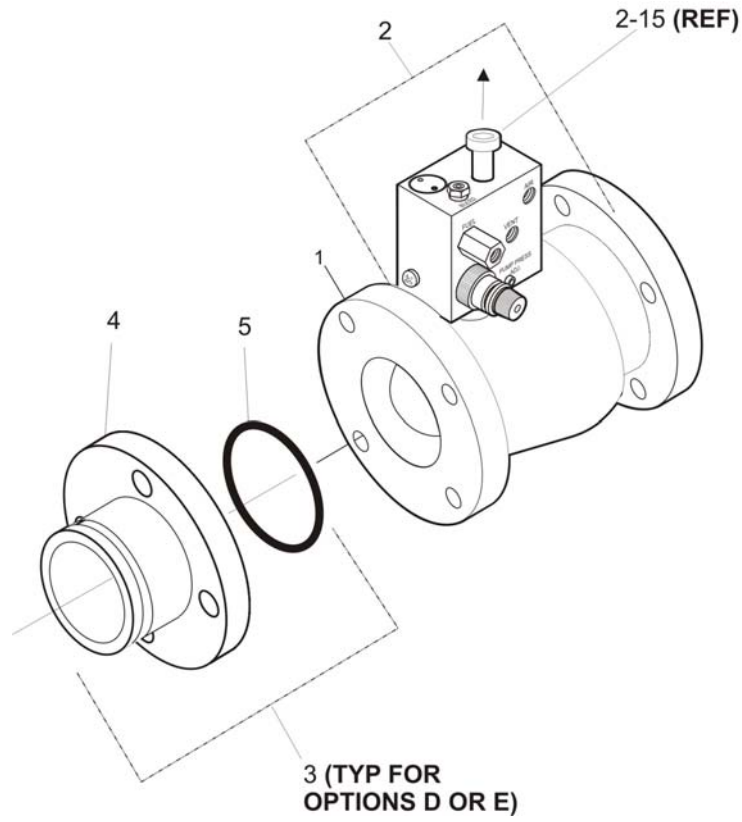

FIGURE 1
AIR OPERATED BYPASS VALVE ILLUSTRATION

TABLE 2.0
 Manifold used on the 64501 & 64511
 Reference Figure 2

Fig.	Item	Part Number	Description	Units/ Assy	Option	Spares/ 10 Units/Yr
2	-	47501	Manifold, Assembly	1	All	1
	1	221581	Manifold	1	All	-
	2	200791	Spring	1	All	-
	3	205772	Check Valve	1	All	-
	4	MS29512-08	Gasket	1	All	10
	5	MS29513-009	O-Ring	1	All	10
	6	205756-2	Housing, Check Valve	1	All	-
	7	MS29513-010	O-Ring	5	All	10
	8	GF35206-276	Screw	5	All	-
	9	47454	Relief Valve	1	All	-
	10	29224-2	Orifice Screw	1	All	-
	11	503*	Vibra- Seal (or equal)	AR	All	-
	12	47414	Bleeder	1	All	-
	12A	221554	Plug	1	All	-
	12B	26664	Poppet	1	All	-
	12C	201201-006	O-Ring	1	All	10
	12D	222047	Spring	1	All	-
	12E	5710-152-30	Washer	1	All	-
	12F	N5000-31-H	Retainer	1	All	-
	13	221592	Retainer	4	All	-
	14	201201-012	O-Ring	5	All	10
	15	GF16997-109	Screw	1	All	-
	16	NAS1352C08H4	Screw	1	All	-
	17	MS29513-022	O-Ring	1	All	10
	18	221591	Cylinder	1	All	-
	19	47452	Piston Assembly	1	All	-
	20	220720	U-Cup Seal	1	All	10
	21	221588	Spacer	1	All	-
	22	MS29513-021	O-Ring	1	All	10
	23	201201-006	O-Ring	1	All	10
	24	221587	Cage	1	All	-
	25	221586	Valve Stem	1	All	-
	26	201201-011	O-Ring	1	All	10
	27	201201-007	O-Ring	1	All	10
	28	28964	Spring	1	All	-
	29	222104	Valve, Cap	1	F	-

* DO NOT USE TEFLON TAPE!

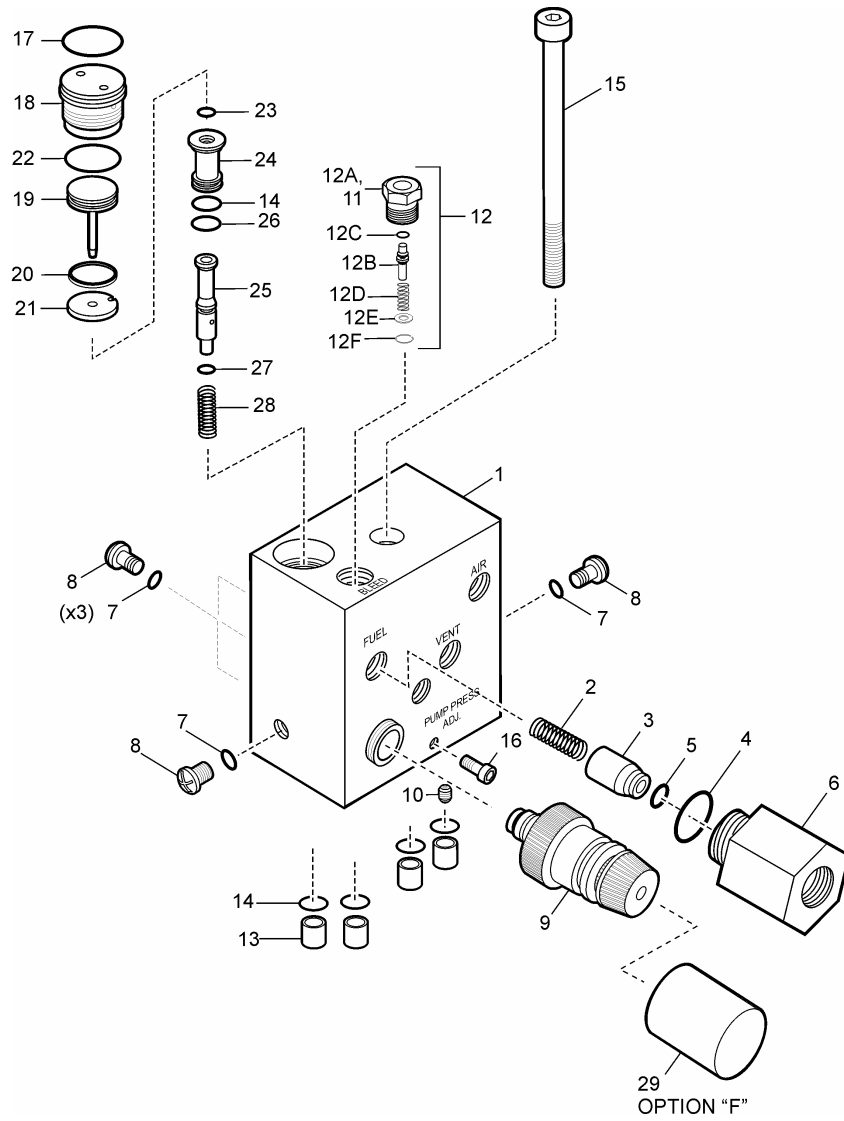

Figure 2
MANIFOLD PARTS BREAKDOWN

TABLE 3.0
3" Valve Assembly
Used on 64501
Reference Figure 3

Fig.	Item	Part Number	Description	Units/ Assy	Spares/10 Units/Yr
3		47510-2	Valve Assembly, 3"	1	1
	1	47506	Valve Housing, 3"	1	-
	2	222165	Seal, Inner Piston	2	10
	2A	MS29513-129	O-Ring	2	10
	3	MS29513-134	O-Ring	2	10
	4	222161	Retainer, Seal Housing	1	-
	4A	221307	Seal Housing	1	-
	5	220685-1250	Screw	4	-
	6	MS29513-038	O-Ring	1	10
	7	201201-231	O-Ring	1	10
	8	MS29513-008	O-Ring	4	10
	9	MS29513-151	O-Ring	1	10
	10	220665	Seal, Outer Piston	1	10
	11	221193	Seal, Housing	1	-
	12	GF16997-18	Screw	6	-
	13	MS29513-042	O-Ring	1	10
	14	GF16997-32L	Screw	4	-
	15	222160	Housing, Seal	1	-
	15A	200758	Seal, Inner Piston	2	10
	16-30	47508-2	Piston Assembly 3"	1	1
	16	38NST188	Nut Self-locking	2	20
	17	GF960C616L	Flat Washer	2	-
	18	MS29513-012	O-Ring	1	10
	19	202291	Washer	1	-
	20	200759	Inner Piston	1	-
	21	221593	Seal Retainer	1	-
	22	221594	Guide	1	-
	23	221595	Seal, Piston Shaft	1	10
	24	203565	O-Ring	1	10
	25	220666	Outer Piston	1	-
	26	220005	Spring	1	-
	27	202290	Shaft	1	-
	28	NAS1351C04-4	Screw	6	-
	29	5720-158-25	Washer, Bronze	2	-
	30	5610-381-50	Washer, Teflon	1	-
	31-35	Left intentionally blank			
	36	AN565AC624H8	Set Screw	1	-

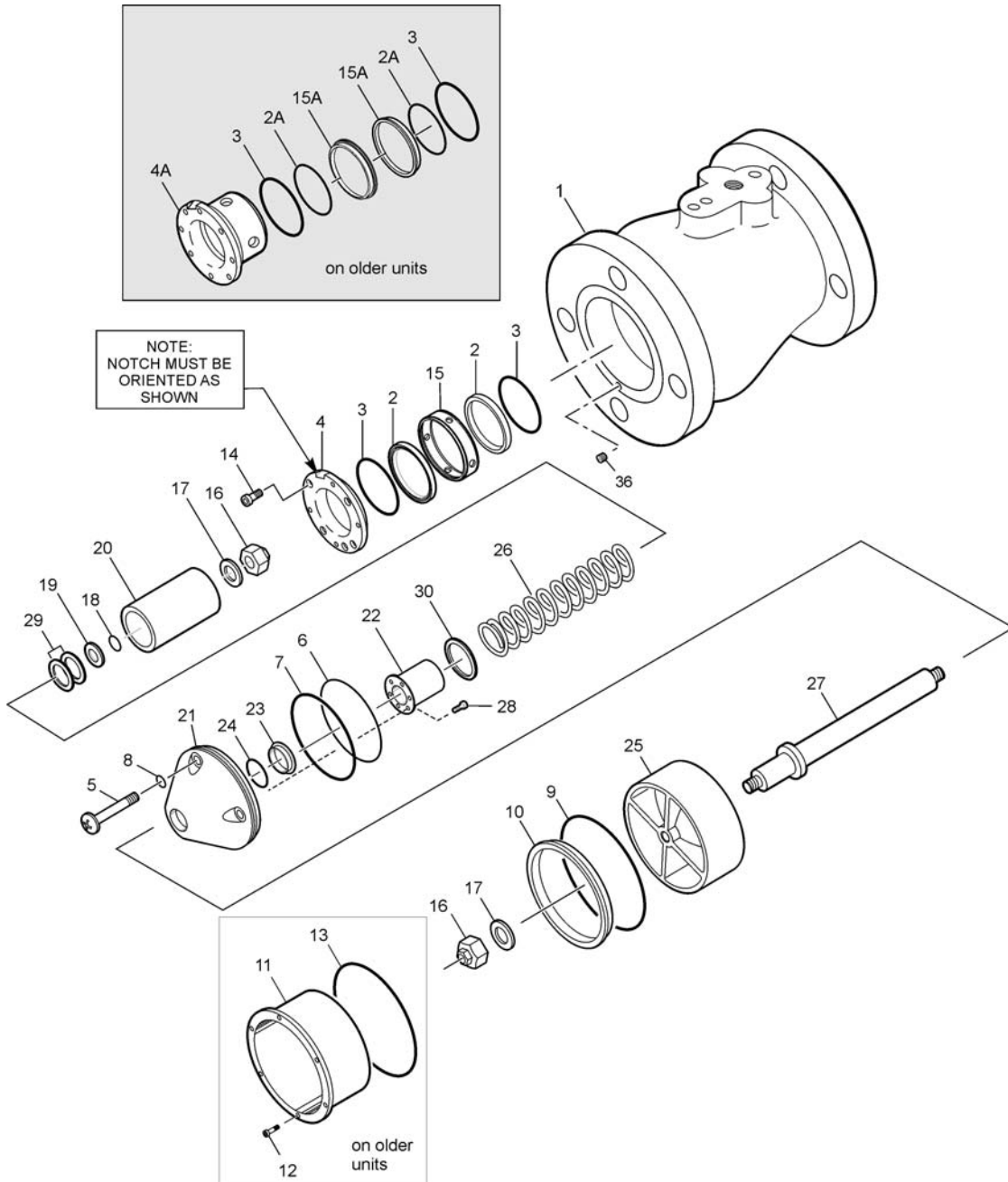

Figure 3
47510-2 3" Valve Assembly
Used on 64501

TABLE 4.0
4" Valve Assembly
Used on 64511
Reference Figure 4

Figure	Item	Part Number	Description	Units / Assy	Spares/10 Units/Yr
4		47511-2	Valve Assembly, 4"	1	1
	1	47507	Housing Assembly	1	-
	2	222165	Seal, Inner Piston	2	10
	2A	MS29513-129	O-Ring	2	10
	3	MS29513-134	O-Ring	2	10
	4	222161	Retainer, Seal Housing	1	-
	4A	221307	Seal Housing	1	-
	5	LP51958-64	Screw	4	-
	6	MS29513-149	O-Ring	1	10
	7	201201-240	O-Ring	1	10
	8	NAS620C10L	Washer	4	-
	9	MS29513-155	O-Ring	1	10
	10	200754	Seal	1	10
	11-13	Left intentionally blank			
	14	GF16997-32L	Screw	4	-
	15	222160	Housing, Seal	1	-
	15A	200758	Seal, Inner Piston	2	10
	16-30	47509-2	Piston Assembly	1	1
	16	38NST188	Nut, Self-locking	2	20
	17	GF960C616L	Washer	2	-
	18	MS29513-012	O-Ring	1	10
	19	202291	Washer	1	-
	20	200759	Inner Piston	1	-
	21	221598	Seal Retainer	1	-
	22	221594	Guide	1	-
	23	221595	Seal, Piston Shaft	1	10
	24	203565	O-Ring	1	10
	25	202334	Piston, Outer	1	-
	26	220005	Spring	1	-
	27	202290	Shaft	1	-
	28	NAS1351C04-4	Screw	6	-
	29	5720-158-25	Washer, Bronze	2	-
	30	5610-381-50	Washer, Teflon	1	-
	31-35	Left intentionally blank			
	36	AN565AC624H8	Set Screw	1	-

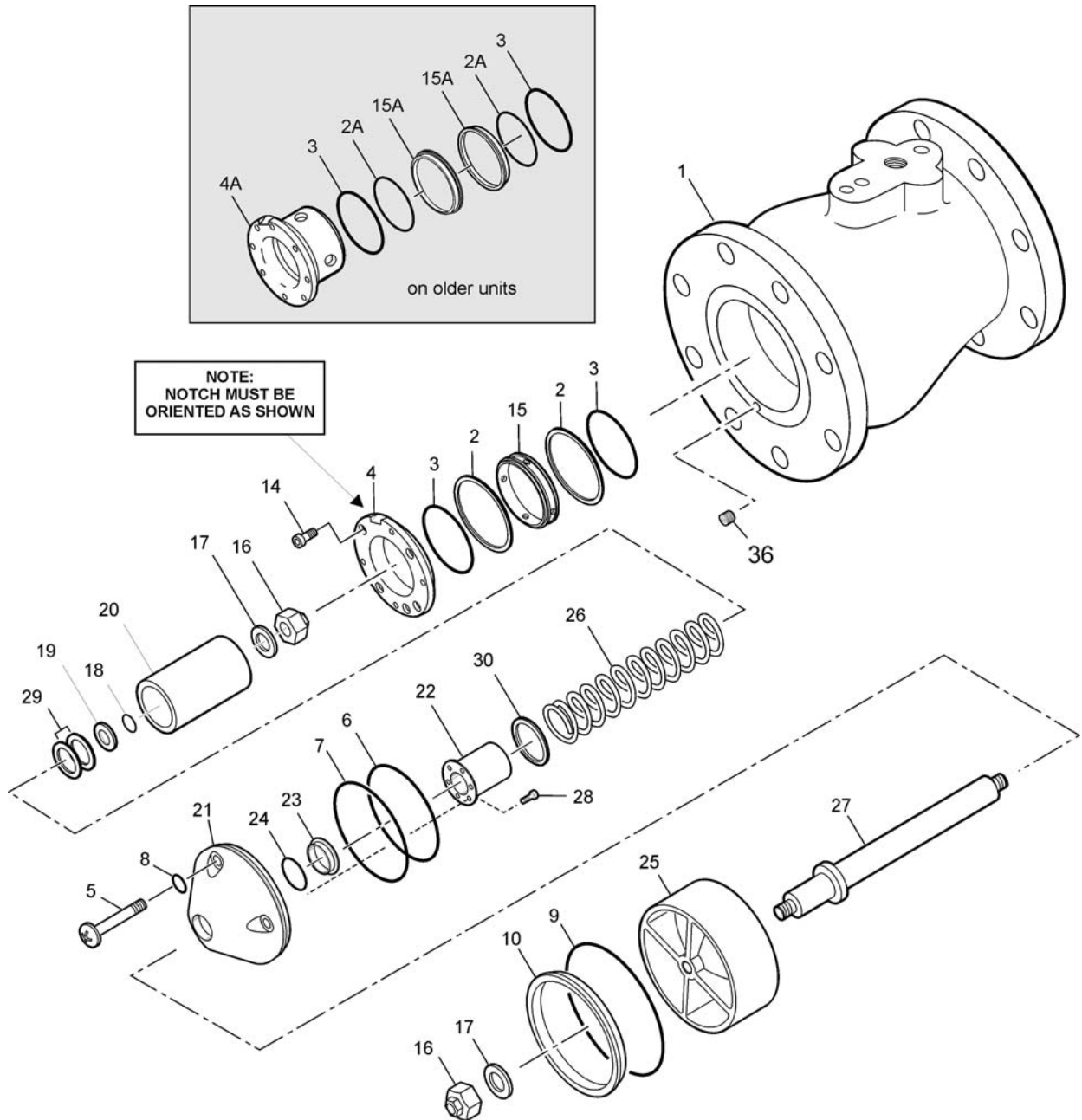
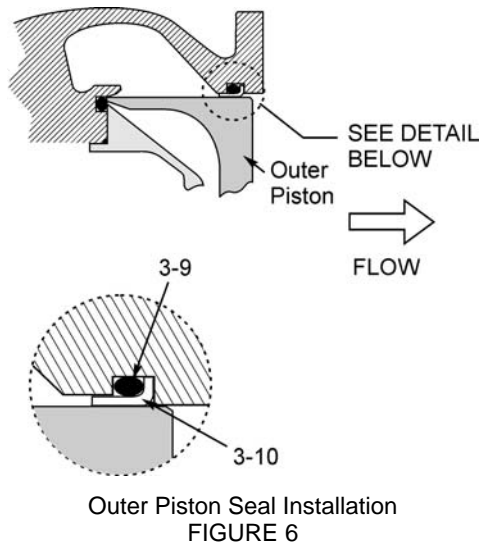
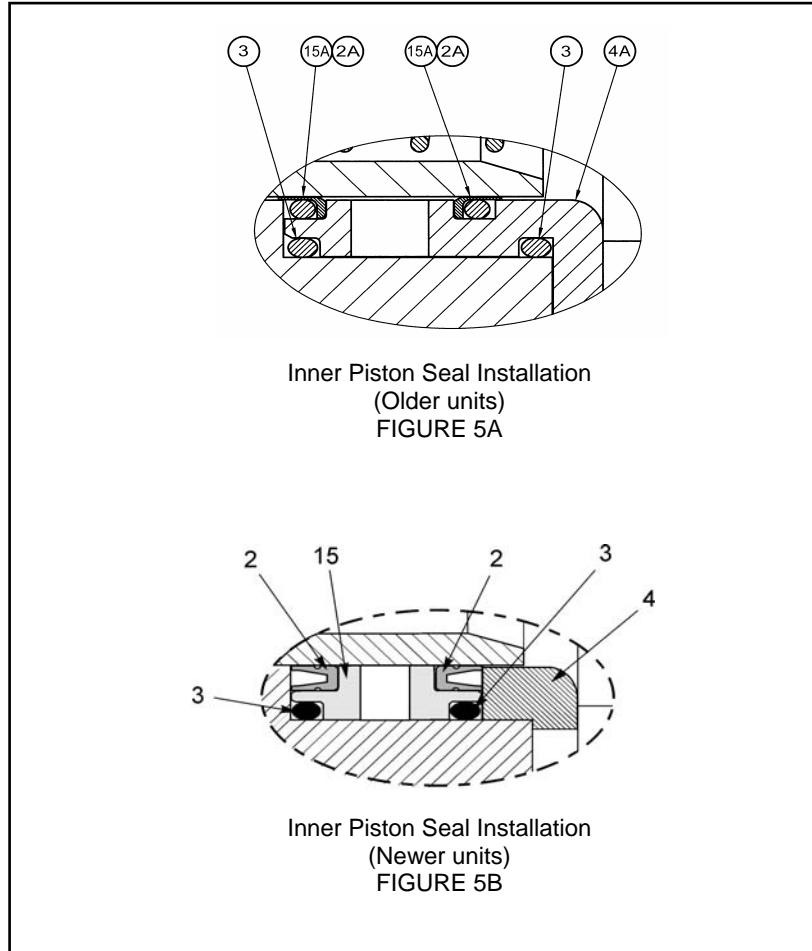

Figure 4
47511-2 4" Valve Assembly
Used on 64511

Table 5.0
Torque Specifications 64501 & 64511

Fig.	Item	Part Number	Description	Torque in.-lb.
3 or 4	14	GF16997-32L	Screw(s)	18 ± 2 in.-lb. (21 ± 2 kg-cm)
3 or 4	16	38NST188	Nut(s)	195 ± 10 in.-lb. (225 ± 12 kg-cm)



Aerospace Group
Conveyance Systems Division
9650 Jeronimo Rd
Irvine, CA 92618
Ph (949) 452-9500
Fax (949) 452-9992



Powering Business Worldwide