



*Powering Business Worldwide*

Aerospace Group  
Conveyance Systems Division  
Carter® Brand Ground Fueling

**SM64505**

September 2008

Applicable addition manuals:  
None

**Maintenance & Repair Manual**

---

**3 Inch & 4 Inch Digital Bypass Pressure Control Valves**

---

**Models 64505 & 64515**

**TABLE OF CONTENTS**

	<u>PAGE</u>
1.0 INTRODUCTION.....	3
2.0 EQUIPMENT DESCRIPTION .....	3
3.0 TABLE OF OPTIONS AND ORDERING INFORMATION .....	3
4.0 DISASSEMBLY .....	3
5.0 INSPECTION.....	5
6.0 REASSEMBLY .....	6
7.0 TEST .....	8
8.0 ILLUSTRATED PARTS CATALOG.....	8
FIGURE 1 - 3" & 4" DIGITAL BY-PASS VALVE ILLUSTRATION .....	9
FIGURE 2 - MANIFOLD PARTS BREAKDOWN .....	10
FIGURE 4 - 4" VALVE ASSEMBLY .....	14
FIGURE 5A - INNER PISTON SEAL INSTALLATION - OLDER UNITS .....	15
FIGURE 5B - INNER PISTON SEAL INSTALLATION - NEWER UNITS .....	15
FIGURE 6 - OUTER PISTON SEAL INSTALLATION.....	15

**NOTE:** The information in this manual is to the latest revision of the products listed above at the time of this printing. Eaton reserves the right to change this manual at its discretion.

**Maintenance, Overhaul & Test Instructions**  
**Carter® Part Numbers 64505 & 64515 3 & 4" Digital Bypass**  
**Pressure Control Valves**

### 1.0 INTRODUCTION

This manual furnishes detailed instructions covering the maintenance and overhaul of Carter Models 64505, 3" & 64515, 4" Digital

Bypass Pressure Control Valves and the various options listed in Section 3.0.

### 2.0 EQUIPMENT DESCRIPTION

Carter Models 64505 and 64515 are the latest versions of the 3" & 4" Digital Bypass Pressure Control Valves that replace the older 64120 and 64060 models. Because they have many characteristics in common, a single manual is used to present both units.

The valves listed above are designed to provide a constant nominal pressure at a remote sense point when used in conjunction with Carter Digital II Pressure Control System 64235. The valves are direct operating spring loaded piston type valves. Pressure control within the system is accomplished by the opening and closing of one or both of the two

solenoids on the valve as directed by the Digital II Control System.

A minimum line size 3/8 inches should be used for all sense lines. Stainless tubing for this line is recommended.

All controls, including opening and closing times, surge control and pressure control are a function of the Digital II System (can also be used with the original Digital System, 64035).

The bleeder on the manifold allows bleeding of air from both the fuel sense line and internally within the manifold. The valve should be installed with the bleeder in the upward position to facilitate proper bleeding.

### 3.0 TABLE OF OPTIONS AND ORDERING INFORMATION

The 64505 and 64515 have common options as listed below.

Carter recommends that at least one end of the valve be flange mounted to the piping system, if both inlet and outlet are Victaulic connections proper bracing must be provided.

#### **Options to be added to 64505 or 64515 Digital Bypass Pressure Control Valves:**

<b>OPTION LETTER</b>	<b>DESCRIPTION</b>	<b>OPTION LETTER</b>	<b>DESCRIPTION</b>
A	Adds 12 VDC Solenoid Valve	E	Adds two Victaulic Adapter Assemblies for use both the inlet and outlet of the unit. (The parts are shipped as loose parts to be used on either end). Mounting fasteners are not provided.
B	Adds 24 VDC Solenoid Valve	Z	LMMF Option (4" valve only): Removes electrical connectors.
D	Adds one Victaulic Adapter Assembly for use on either the inlet or outlet of the unit. (The parts are shipped as loose parts to be used on either end). Mounting fasteners are not provided.		
Example:	64505AD – Basic 3" Digital Bypass Pressure Control Valve with a kit of parts to convert the standard ASA flange on either end to mate a Victaulic fitting and 12 VDC Solenoid Valves.		
	64505BE - Basic 3" Digital Bypass Pressure Control Valve with a kit of parts to convert the standard ASA flange both ends to mate Victaulic fittings and 24 VDC Solenoid Valves.		

### 4.0 DISASSEMBLY

4.1 64505 & 64515 Valve – Note that due to the similarity between the units, this manual covers both units. The appropriate part numbers for the same type of part are noted in Section 8.0.

Victaulic fitting is present on the outlet of the valve assembly remove it. Discard the O-ring (from a Carter furnished fitting) or the gasket that is used to seal the fitting to the valve.

Refer to Figure 1 for this operation. The valve consists of two basic items, the Valve Assembly (1-1) and the Manifold Assembly (1-2). If a

4.2 **MANIFOLD ASSEMBLY** - Refer to Figure 2. Remove the Manifold Assembly (1-2) from the unit by removing Screw (2-15) and pulling the

manifold from the unit, being careful to not lose any of the four Retainers (2-13). Discard O-rings (2-14) when removed.

**Note:** Repairs to the Manifold Assembly (1-2) can be accomplished without removing the main valve from the vehicle system. Be sure that the pressure is relieved before doing this.

- 4.2.1 Do not remove Bleeder Assembly (2-12) unless it is to be replaced due to leakage from its threaded fastener or from the bleeder valve itself. If it is removed then it can be disassembled by removing the Retainer Ring (2-12F) with the proper pliers and all other parts will then come out.
- 4.2.2 Remove Screw (2-8) and O-ring (2-7) and discard the O-ring.
- 4.2.3 Do not remove Orifice Screw (2-10) unless it is to be replaced to change the opening time.
- 4.2.4 Unless there is leakage apparent between the solenoid and manifold, it is not necessary to remove either of the solenoid valves. To remove the Solenoid Valves (2-17) and (2-18) first unscrew the connector screws on the top or side of the assemblies and remove connectors. Then remove the solenoid mounting screws and remove the Solenoids (2-17) and (2-18) from the Manifold (2-1). There are two O-rings (2-19) per solenoid used to seal the interface between each solenoid and the manifold. Remove and discard them.
- 4.3 3" VALVE ASSEMBLY – Refer to Figure 3 for this operation.
- 4.3.1 Rotate Outer Piston (3-25) to access 4 Screws (3-5) these screws are a self locking type screws that utilize a nylon insert in the threads to affect resistance and keep the screw locked in place. They can be reused a number of times before losing their locking ability. Using a torque wrench, remove the screws. If the torque is less than 2 inch lbs. replace during reassembly.
- 4.3.2 Discard O-Rings (3-8).
- 4.3.3 Grasp Outer Piston (3-25) and remove the entire piston/shaft assembly from the outlet of the valve.
- 4.3.4 Remove and discard O-rings (3-7) and (3-6) from the shoulder and groove of the Piston Retainer (3-21).

**WARNING:**

Before proceeding further beware that the outer piston and attaching parts are heavily spring loaded and a vise or similar should be used to safely disassemble the piston assembly.

- 4.3.5 As indicated above, a vise or woodworkers clamp is required to proceed further. Wood blocks should be used to secure the piston

Assemble such that an axial load is exerted yet allows access to both Nuts (3-16).

**NOTE:**

Shaft (3-27) and nut (3-16) are both stainless steel. Nut (3-16) also includes a locking element. Due to this combination there is the possibility when these items are disassembled that the threads may gall or become damaged beyond repair. If it is necessary to disassemble these items replace both nuts (3-16) and consider replacing the shaft (3-27).

**CAUTION:**

Be certain the piston assembly is securely held in place and cannot slip, allowing the unit to forcibly separate when the first nut (3-16) is removed. Forcible separation may cause personal injury. Be careful not to damage the sealing surface of the inner or outer piston.

- 4.3.6 With the assembly securely clamped in place, carefully remove Nut (3-16) from the piston assembly, use Lockease or similar as an aid in removing the nut. Remove Washer (3-17) from piston assembly. Slowly open the clamping device allowing the spring force to cause the inner piston assembly to follow the clamp until all spring force is relieved. Then carefully remove the clamp and lift the Inner Piston (3-20) from the Spring (3-26). Remove the two bronze Washers (3-29) from the Inner Piston (3-20) then remove Spring (3-26) and Teflon Washer (3-30) from the Guide (3-22). Remove O-ring (3-18) and Washer (3-19) from the end of Shaft (3-27). Discard O-ring (3-18).
- 4.3.7 Using two thin 3/8-24 UNF-2B nuts as jam nuts on the shaft (3-27) where Nut (3-16) was removed above, remove Nut (3-16) and Washer (3-17) retaining the outer Piston (3-25) from the Shaft (3-27).
- 4.3.8 Remove Screws (3-28) from the spring Guide (3-22) to remove Seal (3-23) and O-ring (3-24) from retainer. Discard O-ring (3-24).
- 4.3.9 On older versions of the 3" valve, it will be necessary to remove Screws (3-12) and remove Seal Housing (3-11) from Body (3-1). Remove and discard O-ring (3-13).
- 4.3.10 Remove and discard Seal (3-10) and O-ring (3-9).
- 4.3.11 Remove Screws (3-14) and then pull out Seal Housing Retainer (3-4) and Housing (3-15) with Seals (3-2) and O-rings (3-3). Discard Seals (3-2) and O-rings (3-3).

**Note: It is recommended the user upgrade to the new seal cartridge. The new design with the energized Seal (3-2) and O-Ring (3-3) are included in the overhaul kit KD64500-5. These seals will not work with the old-style cartridge. Request a -8 kit for hardware items (3-4 & 3-15) to complete the upgrade. This configuration provides a more robust seal, reducing leakage and frequency for overhaul of the seal cartridge.**

- 4.3.12 Older Units Seal Cartridge: Remove Screws (3-14) and then pull out Seal Housing (3-4A). Then remove and discard Seals (3-15A) and O-rings (3-2A) and (3-3).
- 4.3.13 Newer versions are equipped with a Set-Screw (3-36). It is not necessary to remove this screw.
- 4.4 4" VALVE ASSEMBLY – Refer to Figure 4 for this operation.
- 4.4.1 Rotate Outer Piston (4-25) to access 4 Screws (4-5) these screws are a self locking type screws that utilize a nylon insert in the threads to affect resistance and keep the screw locked in place. They can be reused a number of times before losing their locking ability. Using a torque wrench, remove the screws. If the torque is less than 2 inch lbs. replace during reassembly. Remove the four Screws (4-5) and Washers (4-8).
- 4.4.2 Grasp Outer Piston (4-25) and remove the entire piston/shaft assembly from the outlet of the valve.
- 4.4.3 Remove and discard O-rings (4-7) and (4-6) from the shoulder and groove of the Piston Retainer (4-21).

**WARNING:**

Before proceeding further beware that the outer piston and attaching parts are heavily spring loaded and a vise or similar should be used to safely disassemble the piston assembly.

- 4.4.4 As indicated above, a vise or woodworkers clamp is required to proceed further. Wood blocks should be used to secure the piston.

Assemble such that an axial load is exerted yet allows access to both Nuts (4-16).

**NOTE:**

Shaft (4-27) and nut (4-16) are both stainless steel. Nut (4-16) also includes a locking element. Due to this combination there is the possibility when these items are disassembled that the threads may gall or become damaged beyond repair. If it is necessary to disassemble these items replace both nuts (4-16) and consider replacing the shaft (4-27).

**CAUTION:**

Be certain the piston assembly is securely held in place and cannot slip, allowing the unit to forcibly separate when the first nut (4-16) is removed. Forcible separation may cause personal injury. Be careful not to damage the sealing surface of the inner or outer piston.

- 4.4.5 With the assembly securely clamped in place, carefully remove Nut (4-16) from the piston assembly, use Lockease or similar as an aid in removing the nut. Remove Washer (4-17) from piston assembly. Slowly open the clamping device allowing the spring force to cause the inner piston assembly to follow the clamp until all spring force is relieved. Then carefully remove the clamp and lift the Inner Piston (4-20) from the Spring (4-26). Remove the two bronze Washers (4-29) from the Inner Piston (4-20) then remove Spring (4-26) and Teflon Washer (4-30) from the Guide (4-22). Remove O-ring (4-18) and Washer (4-19) from the end of Shaft (4-27). Discard O-ring (4-18).
- 4.4.6 Using two thin 3/8-24 UNF-2B nuts as jam nuts on the shaft (4-27) where Nut (4-16) was removed above, remove Nut (4-16) and Washer (4-17) retaining the outer Piston (4-25) from the Shaft (4-27).
- 4.4.7 Remove Screws (4-28) from the spring Guide (4-22) to remove Seal (4-23) and O-ring (4-24) from retainer. Discard O-ring (4-24).
- 4.4.8 Remove and discard Seal (4-10) and O-ring (4-9).
- 4.4.9 Remove Screws (4-14) and then pull out Seal Housing Retainer (4-4) and Housing (4-15) with Seals (4-2) and O-rings (4-3). Discard seals (4-2) and O-rings (4-3).
- Note: It is recommended the user upgrade to the new seal cartridge. The new design with the energized Seal (4-2) and O-Ring (4-3) are included in the overhaul kit KD64500-6. These seals will not work with the old-style cartridge. Request a -8 kit for hardware items (4-4 & 4-15) to complete the upgrade. This configuration provides a more robust seal, reducing leakage and frequency for overhaul of the seal cartridge.**
- 4.4.10 Older Units Seal Cartridge: Remove Screws (4-14) and then pull out Seal Housing (4-4A). Then remove and discard Seals (4-15A) and O-rings (4-2A) and (4-3).
- 4.4.11 Newer versions are equipped with a Set-Screw (4-36). It is not necessary to remove this screw.

## 5.0 INSPECTION

It is recommended that all O-rings and seals be replaced at every overhaul. Inspect all metal parts for dings, gouges, abrasions, etc. On the inner and outer piston use 320 grit paper to remove any sharp edges if required be careful not to remove the hard anodize finish on these pistons. Check the knife-edge of the outer piston where it meets O-ring (3-7 or 4-7). This edge should be smooth and free of any imperfections. If any imperfections are found that cannot be polished from the

surfaces or the knife-edge the part should be replaced.

Inspect all metal parts for dings, gouges, abrasions, etc. Use 320 grit paper to smooth and remove sharp edges. Replace any part with damage exceeding 15% of local wall thickness. Use alodine 1200 to touch up bared aluminum.

Note: Nuts (3-16) & (4-16) should not be reused.

## 6.0 REASSEMBLY

Reassembly is accomplished in essentially the reverse order of disassembly. A light coat of petroleum jelly may be used during overhaul but do not use any other type of lubricant, **ONLY PETROLEUM JELLY.**

Note: Lightly lubricate all O-rings except O-Ring (3-9) or (4-9) and O-Ring (3-2A) or (4-2A) [old seal cartridge design] to be installed dry.

- 6.1 Make certain all components are clean and free from oil, grease, or any other corrosion resistant compound on all interior or exterior surfaces. Wash all parts with cleaning solvent, Federal Specification P-D-680, and dry thoroughly with a clean, lint-free cloth or compressed air.

### WARNING:

Use cleaning solvent in a well-ventilated area. Avoid breathing of fumes and excessive solvent contact with skin. Keep away from open flame.

**5. These seals will not work with the old-style cartridge. Request a -8 kit for hardware items (3-4 & 3-15) to complete the upgrade. This configuration provides a more robust seal, reducing leakage and frequency for overhaul of the seal cartridge.**

- 6.2.3 Seal Cartridge newer units: O-rings (3-3) should be fitted onto the grooves of Seal Housing (3-15). The lubricated Inner Piston Seals (3-2) should be installed on the inside diameter of the Seal Housing (3-15) per Figure 5B. Now insert the assembly into the main Housing (3-1) with the "notch" on (3-4) oriented as shown on Figure 3. Be careful not to damage the seals during installation.
- 6.2.4 Install the Seal Housing Retainer (3-4) into the main Housing (3-1) by installing Screws (3-14). Torque Screws (3-4) to  $18 \pm 2$  in.-lb. ( $21 \pm 2$  kg-cm). When properly installed, it is not necessary to polish the new type seals.

### NOTE:

Shaft (3-27) and nut (3-16) are both stainless steel. Nut (3-16) also includes a locking element. Due to this combination there is the possibility when these items are disassembled that the threads may gall or become damaged beyond repair. If it is necessary to disassemble these items replace both nuts (3-16) and consider replacing the shaft (3-27).

- 6.2 3" VALVE ASSEMBLY- Refer to Figure 3 for this operation.
- 6.2.1 Seal Cartridge older units: Place O-rings (3-3) into the grooves of the Seal Housing (3-4A) outside diameter. Install O-rings (3-2A) in o-ring grooves on inside diameter of Housing. **DO NOT LUBRICATE.** Next install Piston Seals (3-15A) in inside diameter grooves over O-rings (3-2A) per Figure 5A. Smooth the combination of the Seal and O-ring (3-2A) with the finger to assure that they are installed completely in the seal grooves. Apply a light coat of lube and then insert the assembly into the main Housing (3-1) with the "notch" on (3-4A) oriented as shown on Figure 3.
- 6.1.2 Install Screws (3-14) and torque to  $18 \pm 2$  in.-lb. ( $21 \pm 2$  kg-cm). Condition seals with seal run-in tool AF42208-1 [use instructions from the SM64800 manual.]

**Note: It is recommended the user upgrade to the new seal cartridge. The new design with the energized Seal (3-2) and O-Ring (3-3) are included in the overhaul kit KD64500-**

- 6.3 Assemble Outer Piston (3-25) onto Shaft (3-27) using Washer (3-17) and Nut (3-16). Use two thin nuts 3/8-24 UNF-2B nuts as jam nuts on the opposite end of the Shaft (3-27) and tighten the Nut (3-16)  $195 \pm 10$  in.-lb. ( $225 \pm 12$  kg-cm).
- 6.3.1 Install O-ring (3-24) on Seal (3-23) and install in Retainer (3-21). The leg or hook end of the seal should point toward the Outer Piston (3-25). Press the seal into place very carefully in the retainer. Install Screws (3-28) through spring Guide (3-22) and tighten screws equally.

- 6.3.2 Apply a light coat of lube to inside ID of Seal (3-23) and slide the Retainer (3-21) onto Shaft (3-27).
- 6.3.3 Install Teflon Washer (3-30) on the shoulder of the spring Guide (3-22).
- 6.3.4 Place Washer (3-19) over the end of the Shaft (3-27) and install O-ring (3-18) above the washer.
- 6.3.5 Install Spring (3-26) onto Guide (3-22). Place the two bronze Washers (3-29) on top of the spring and hold them in place by placing the Inner Piston (3-20) over Spring (3-26). Insert assembly into the clamping device used during disassembly. Compress the assembly and allow access to install the Washer (3-17) and Nut (3-16) on the end of the shaft and tighten to  $195 \pm 10$  in.-lb. ( $225 \pm 12$  kg-cm).
- 6.3.6 Install the O-ring (3-6) into groove in Retainer (3-21). Install O-ring (3-7) over the end of the Retainer (3-21) to where it rests against the retainer's shoulder.
- 6.3.7 Insert the non-lubricated O-ring (3-9) into the groove in the outlet of Housing (3-1) Install Seal (3-10) over O-ring (3-9) (Refer to Figure 6).
- 6.3.8 On older versions, if equipped, place O-ring (3-13) over Retainer (3-11) and install the assembly into the main housing fully without cutting the O-ring (3-13). Rotate the retainer to line up the four holes with the mating holes in the housing and install Screws (3-12).
- 6.3.9 Insert piston assembly into the housing and rotate Outer Piston (3-25) to line up the four holes with the mating holes in the housing. Place O-rings (3-8) over Screws (3-5) and tighten in a cross manner.
- 6.3.10 On newer units with a Set-Screw (3-36) ensure the screw has not become loose and remains snug in the housing.
- 6.4 4" VALVE ASSEMBLY - Refer to Figure 4 for this operation.
- 6.4.1 Seal Cartridge older units: Place O-rings (4-3) into the grooves of the Seal Housing (4-4A) outside diameter. Install O-rings (4-2A) in O-ring grooves on inside diameter of Housing. DO NOT LUBRICATE. Next install Piston Seals (4-15A) in inside diameter grooves over O-rings (4-2A) per Figure 5A. Smooth the combination of the Seal and O-ring (4-2A) with the finger to assure that they are installed completely in the seal grooves. Apply a light coat of lube and then insert the assembly into the main Housing (3-1) with the "notch" on (4-4A) oriented as shown on Figure 3.
- 6.4.2 Install Screws (4-14) and torque to  $18 \pm 2$  in.-lb. ( $21 \pm 2$  kg-cm). Condition seals with seal run-in tool AF42208-1 [use instructions from the SM64800 manual.]

**Note:** It is recommended the user upgrade to the new seal cartridge. The new design with the energized Seal (4-2) and O-Ring (4-3) are included in the overhaul kit KD64500-6. These seals will not work with the old-style cartridge. Request a -8 kit for hardware items (4-4 & 4-15) to complete the upgrade. This configuration provides a more robust seal, reducing leakage and frequency for overhaul of the seal cartridge.

- 6.4.3 Seal Cartridge newer units: O-rings (4-3) should be fitted onto the grooves of Seal Housing (4-15). The lubricated Inner Piston Seals (4-2) should be installed on the inside diameter of the Seal Housing (4-15) per Figure 5B. Now insert the assembly into the main Housing (4-1) with the "notch" on (4-4) oriented as shown on Figure 3. Be careful not to damage the seals during installation.
- 6.4.4 Install the Seal Housing Retainer (4-4) into the main Housing (4-1) by installing Screws (4-14). Torque Screws (4-4) to  $18 \pm 2$  in.-lb. ( $21 \pm 2$  kg-cm). When properly installed, it is not necessary to polish the new type seals.

**NOTE:**

Shaft (4-27) and nut (4-16) are both stainless steel. Nut (4-16) also includes a locking element. Due to this combination there is the possibility when these items are disassembled that the threads may gall or become damaged beyond repair. If it is necessary to disassemble these items replace both nuts (4-16) and consider replacing the shaft (4-27).

- 6.4.5 Assemble Outer Piston (4-25) onto Shaft (4-27) using Washer (4-17) and Nut (4-16). Use two thin nuts 3/8-24 UNF-2B nuts as jam nuts on the opposite end of the Shaft (4-27) and tighten the Nut (4-16)  $195 \pm 10$  in.-lb. ( $225 \pm 12$  kg-cm).
- 6.4.6 Install O-ring (4-24) on Seal (4-23) and install in Retainer (4-21). The leg or hook end of the seal should point toward the Outer Piston (4-25). Press the seal into place very carefully in the retainer. Install Screws (4-28) through spring Guide (4-22) and tighten screws equally.
- 6.4.7 Apply a light coat of lube to inside ID of Seal (4-23) and slide the Retainer (4-21) onto Shaft (4-27).
- 6.4.8 Install Teflon Washer (4-30) on the shoulder of the spring Guide (4-22).
- 6.4.9 Place Washer (4-19) over the end of the Shaft (4-27) and install O-ring (4-18) above the washer.
- 6.4.10 Install Spring (4-26) onto Guide (4-22). Place the two bronze Washers (4-29) on top of the spring and hold them in place by placing the Inner Piston (4-20) over Spring (4-26). Insert

- assembly into the clamping device used during disassembly. Compress the assembly and allow access to install the Washer (4-17) and Nut (4-16) on the end of the shaft and tighten to 195 ± 10 in.-lb. (225 ± 12 kg-cm).
- 6.4.11 Install the O-ring (4-6) into groove in Retainer (4-21). Install O-ring (4-7) over the end of the Retainer (4-21) to where it rests against the retainer's shoulder.
  - 6.4.12 Insert the non-lubricated O-ring (4-9) into the groove in the outlet of Housing (4-1) Install Seal (4-10) over O-ring (4-9) (Refer to Figure 6).
  - 6.4.13 Insert piston assembly into the housing and rotate Outer Piston (4-25) to line up the four holes with the mating holes in the housing. Place Washers (4-8) over Screws (4-5) and tighten in a cross manner.
  - 6.4.14 On newer units with a Set-Screw (4-36) ensure the screw has not become loose and remains snug in the housing.

6.5 MANIFOLD ASSEMBLY

- 6.5.1 Assemble in the reverse order.
- 6.5.2 If Solenoids (2-17) or (2-18) were removed, first secure the O-rings (2-19) to the bottom of the Solenoid Valves (2-17) or (2-18) by applying a small amount of petroleum jelly to the bottom of the valve to help hold the interface o-rings in place, then install solenoids on the Manifold (2-1) using the solenoid mounting screws. Mount the connectors onto the solenoids and secure in place by use of the connector retaining screws.

- 6.5.3 If for some reason the Orifice Screw (2-10) was removed reinstall it at this time.
- 6.5.4 Place O-ring (2-7) over Screw (2-8) and install.
- 6.5.5 If the bleed valve was disassembled begin by placing O-ring (2-12C) over the Poppet (12B). Lay Plug (2-12A) upside down and insert assembled (2-12B) [Reference Figure 2]. Place Spring (2-12D) over the shaft of Poppet (2-12B). Place the Washer (2-12E) on the Spring (2-12D). Compress assembled unit thus far and use snap or lock ring pliers to separate the Retainer (2-12F) and install in the retainer groove on the inside diameter of the bleeder Plug (2-12A).
- 6.5.6 Use a product similar to Vibra Seal (2-11) on the pipe threads on item (2-12A) and install Bleeder Assembly (2-12) in bleeder port of manifold.

**NOTE:**

Do not use Teflon tape on any threads in this product. Loose pieces of tape can cause failure of the product.

- 6.5.7 Be careful to install Retainers (2-13) and O-rings (2-14) in the proper places. One may use a coating of petroleum jelly to hold them in place while assembling the manifold to the main valve.
- 6.5.8 Place the manifold assembly onto the valve and retain with Screw (2-15) tightening to hold securely in place.

7.0 TEST

7.1 The following test procedures will be accomplished after overhaul:

7.2 TEST CONDITIONS

Test media shall be JP-8 MIL-T-83133, Jet A, an odorless kerosene or Stoddard type solvent MIL-PRF-7024E Type II.

**BLEEDING VALVE!**

Before testing or use the valve must be bled of all trapped air. After pressurizing the unit, use a plastic rod to depress Poppet (2-12B) with a rag around the unit to absorb fuel flow from the bleeder. This should be done long enough to assure all trapped air is exhausted from the valve.

- 7.2.3 Pressurized the valve inlet to 120-psi with both solenoids de-energized. Fill the valve with test fluid while bleeding all air from it through a small valve on the outlet. Maintain pressure for one minute while visually inspecting for indication of external leakage. None should be apparent. Maintain the pressure for one minute and check for external leakage. None shall be apparent. Energize the solenoids and pressurize both inlet and outlet to 120 psi. Maintain the pressure for one minute and check for external leakage. None shall be apparent.

7.3 VALVE BODY AIR-TIGHTNESS TEST

Note that the various ports noted below are identified by engraved markings, "TO PUMP INLET", and "BLEED".

- 7.3.3 Repeat the test in 7.3.2 at 4-6 psi.
- 7.3.4 Release internal pressure and drain the test fluid.

7.3.1 Apply 40-psi air pressure to the TO PUMP INLET pump. Fill the valve through the inlet with test fluid while bleeding air from the outlet

7.4 FUNCTIONAL TEST

Testing for functionally can be accomplished on the vehicle equipped with a Digital II System



unless there is a complete test rig available. If there is, contact Carter for more details on how

to test for full function.

8.0

**ILLUSTRATED PARTS CATALOG**

Tables 1.0 – 4.0 tabulate the parts and sub-assemblies comprising the 64505 & 64515 Digital Bypass Pressure Control Valves. The item

numbers of the table are keyed to the exploded views of the valve diagrammed in Figures 1 -4.

**TABLE 1.0**  
Reference Figure 1

Fig.	Item	Part Number	Description	Units/ Assy	Used On	Spares/10 Units/Yr
1	1	47510-2	Valve Assembly – 3" Bypass .....	1	64505	-
		47511-2	Valve Assembly – 4" Bypass .....	1	64515	-
2	2	47505-1	Manifold Assembly – 12 VDC .....	1	Option A	-
		47505-2	Manifold Assembly – 24 VDC .....	1	Option B	-
3	3	47512	Victaulic Adapter Assembly – 3" Valves	1 or 2	64505D or E	-
4	4	221596	Victaulic/ANSI Flange Adapter – 3" ..	1	47512	-
5	5	MS29513-245	O-ring .....	1	47512	10
3	3	47513	Victaulic Adapter Assembly – 4" Valves .	1 or 2	64515D or E	-
4	4	221597	Victaulic/ANSI Flange Adapter – 4" ..	1	47513	-
5	5	MS29513-255	O-ring	1	47513	10

Kits to overhaul the main valve assembly and the manifold are available (see below). If the entire valve is to be overhauled, a minimum of two kits will be required, one for the main valve and one for the manifold assembly.

- KD64500-4 Kit - Contains the parts needed to overhaul the above manifold assembly – contains items 2-7, 2-12C, 2-14 & 2-19.
- KD64500-5 Kit – Contains the parts needed to overhaul the 47510-2 3" valve assembly – Contains items 3-2, 3-3, 3-6, 3-7, 3-8, 3-9, 3-10, 3-13, 3-18, 3-23 & 3-24.
- KD64500-6 Kit – Contains the parts needed to overhaul the 47511-2 4" valve assembly – Contains items 4-2, 4-3, 4-6, 4-7, 4-9, 4-10, 4-18, 4-23 & 4-24.
- KD64500-7 Kit – Contains the interface o-rings used on the Victaulic Adapters option D or E. Contains items- 1-5 for both 3" and 4" adapters.
- KD64500-8 Kit – Contains the housing and retainer necessary to upgrade to the now standard seal cartridge design. Contains items – 3-4 and 3-15 (or 4-4 and 4-15).

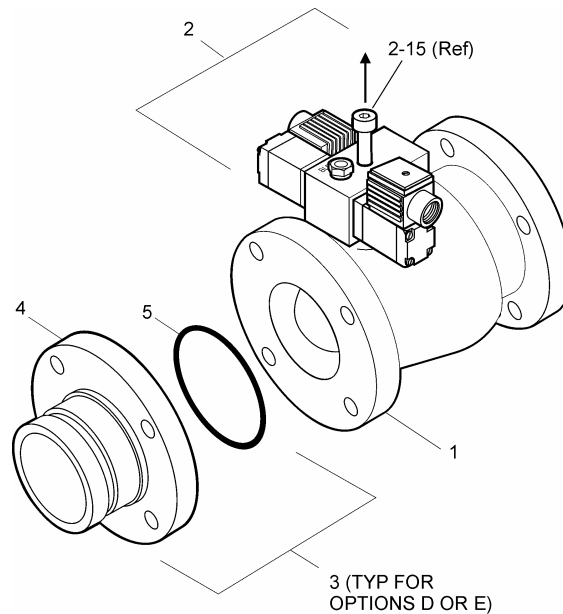
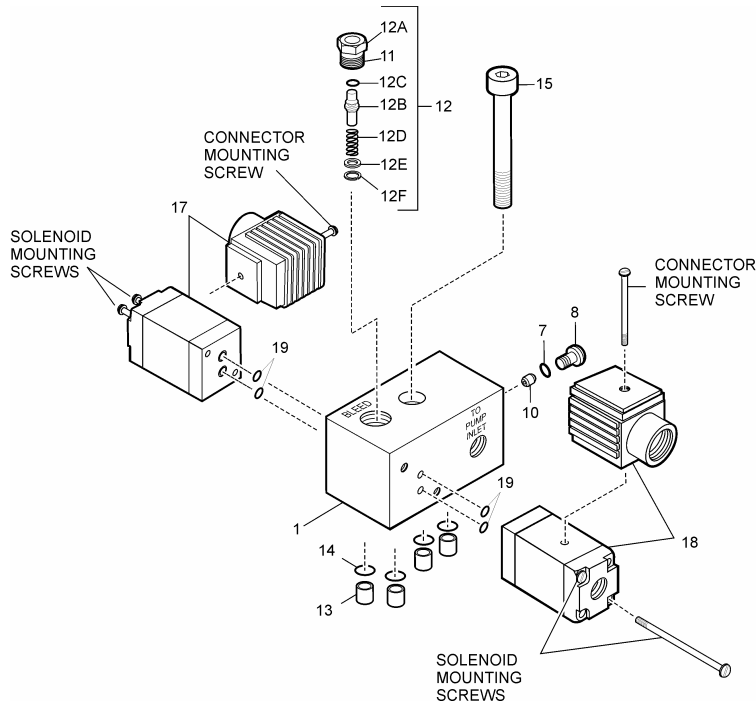

**FIGURE 1**  
**DIGITAL BYPASS VALVE ILLUSTRATION**

**TABLE 2.0**  
 Manifold used on the 64505 & 64515  
 Reference Figure 2

Fig	Item	Part Number	Description	Units/ Assy	Option	Spares/10 Units/Yr
2		47505	Manifold Assembly .....	1	All	-
	1	221584	Manifold .....	1	All	-
	2-6		Left intentionally blank			
	7	MS29513-010	O-Ring.....	1	All	10
	8	GF35206-276	Screw .....	1	All	-
	9		Left intentionally blank			
	10	29224-4	Orifice Screw.....	1	All	-
	11	503*	Vibra- Seal (or equal).....	AR	All	-
	12	47414	Bleeder.....	2	All	-
	12A	221554	Plug.....	2	All	-
	12B	26664	Poppet.....	2	All	-
	12C	201201-006	O-Ring.....	2	All	20
	12D	222047	Spring.....	2	All	-
	12E	5710-152-30	Washer.....	2	All	-
	12F	N5000-31-H	Retainer .....	2	All	-
	13	221592	Retainer .....	4	All	-
	14	MS29513-012	O-Ring.....	4	All	10
	15	GF16997-103	Screw .....	1	All	-
	16		Left intentionally blank			
	17	220785-2	Solenoid Valve – 12 VDC.....	1	A	-
	17	220785-4	Solenoid Valve – 24 VDC.....	1	B	-
	18	2220785-1	Solenoid Valve – 12 VDC.....	1	A	-
	18	220785-3	Solenoid Valve – 24 VDC.....	1	B	-
	19	100000K	O-Ring.....	4	All	40

\* **DO NOT USE TEFLON TAPE!**



**Figure 2**  
**MANIFOLD PARTS BREAKDOWN**

**TABLE 3.0**  
 3" Valve Assembly  
 Used on 64505  
 Reference Figure 3

Fig.	Item	Part Number	Description	Units/ Assy	Spares/10 Units/Yr
3		47510-2	Valve Assembly, 3" .....	1	1
	1	47506	Valve Housing, 3" .....	1	-
	2	222165	Seal, Inner Piston .....	2	10
	2A	MS29513-129	O-Ring .....	2	10
	3	MS29513-134	O-Ring .....	2	10
	4	222161	Retainer, Seal Housing .....	1	-
	4A	221307	Seal Housing .....	1	-
	5	220685-1250	Screw .....	4	-
	6	MS29513-038	O-Ring .....	1	10
	7	201201-231	O-Ring .....	1	10
	8	MS29513-008	O-Ring .....	4	10
	9	MS29513-151	O-Ring .....	1	10
	10	220665	Seal, Outer Piston .....	1	10
	11	221193	Seal, Housing .....	1	-
	12	GF16997-18	Screw .....	6	-
	13	MS29513-042	O-Ring .....	1	10
	14	GF16997-32L	Screw .....	4	-
	15	222160	Housing, Seal .....	1	-
	15A	200758	Seal, Inner Piston .....	2	10
	16-30	47508-2	Piston Assembly 3" .....	1	1
	16	38NST188	Nut Self-locking .....	2	20
	17	GF960C616L	Flat Washer .....	2	-
	18	MS29513-012	O-Ring .....	1	10
	19	202291	Washer .....	1	-
	20	200759	Inner Piston .....	1	-
	21	221593	Seal Retainer .....	1	-
	22	221594	Guide .....	1	-
	23	221595	Seal, Piston Shaft .....	1	10
	24	203565	O-Ring .....	1	10
	25	220666	Outer Piston .....	1	-
	26	220005	Spring .....	1	-
	27	202290	Shaft .....	1	-
	28	NAS1351C04-4	Screw .....	6	-
	29	5720-158-25	Washer, Bronze .....	2	-
	30	5610-381-50	Washer, Teflon .....	1	-
	31-35	Left intentionally blank			
	36	AN565AC624H8	Set Screw .....	1	-

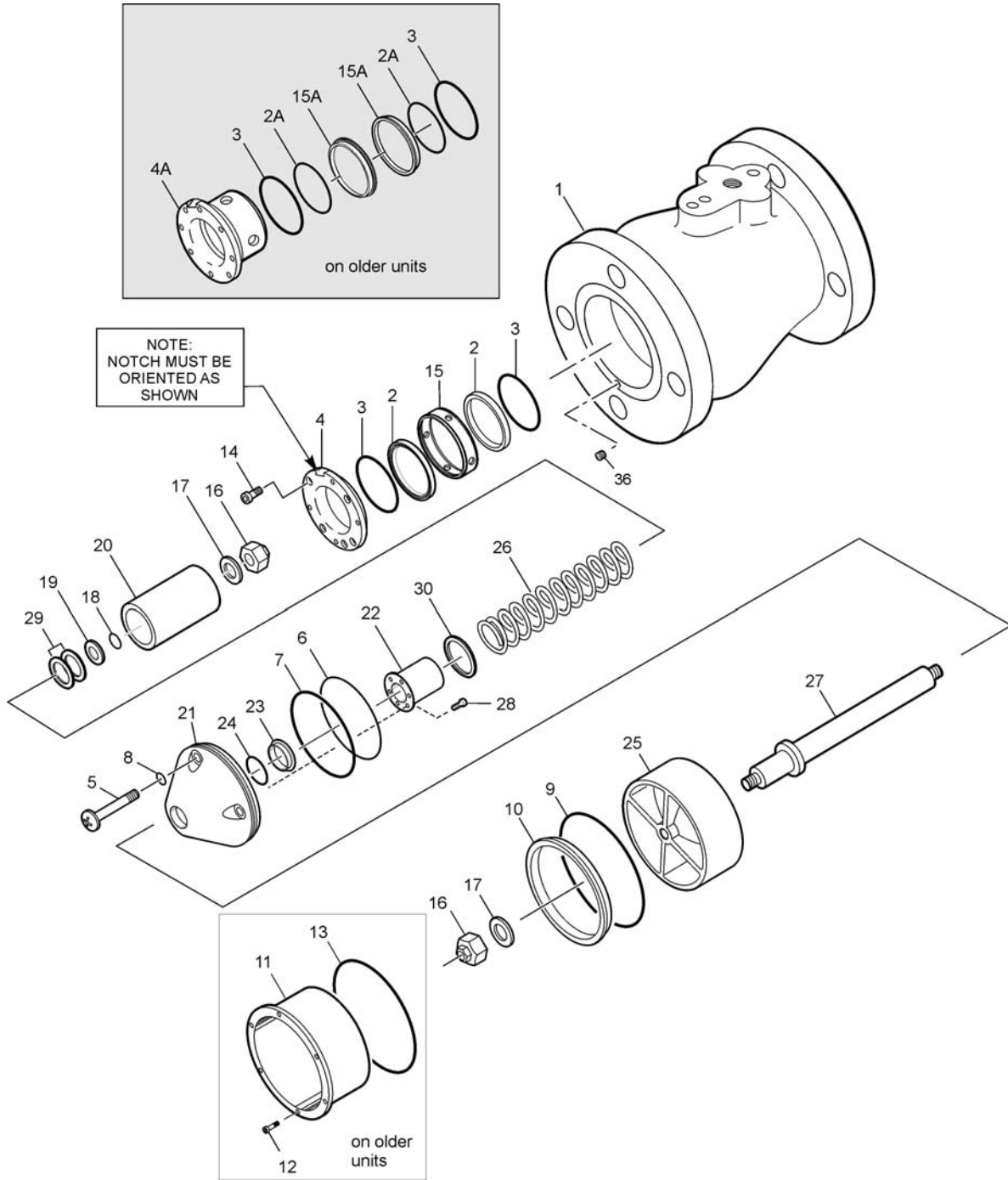

**Figure 3**  
**47510-2 3" Valve Assembly**  
**Used on 64505**

TABLE 4.0  
4" Valve Assembly  
Used on 64515  
Reference Figure 4

Fig.	Item	Part Number	Description	Units / Assy	Spares/10 Units/Yr
4		47511-2	Valve Assembly, 4" .....	1	1
	1	47507	Housing Assembly .....	1	-
	2	222165	Seal, Inner Piston .....	2	10
	2A	MS29513-129	O-Ring .....	2	10
	3	MS29513-134	O-Ring .....	2	10
	4	222161	Retainer, Seal Housing .....	1	-
	4A	221307	Seal Housing .....	1	-
	5	LP51958-64	Screw .....	4	-
	6	MS29513-149	O-Ring .....	1	10
	7	201201-240	O-Ring .....	1	10
	8	NAS620C10L	Washer .....	4	-
	9	MS29513-155	O-Ring .....	1	10
	10	200754	Seal .....	1	10
	11-13	Left intentionally blank			
	14	GF16997-32L	Screw .....	4	-
	15	222160	Housing, Seal .....	1	-
	15A	200758	Seal, Inner Piston .....	2	10
	16-30	47509-2	Piston Assembly .....	1	1
	16	38NST188	Nut, Self-locking .....	2	20
	17	GF960C616L	Washer .....	2	-
	18	MS29513-012	O-Ring .....	1	10
	19	202291	Washer .....	1	-
	20	200759	Inner Piston .....	1	-
	21	221598	Seal Retainer .....	1	-
	22	221594	Guide .....	1	-
	23	221595	Seal, Piston Shaft .....	1	10
	24	203565	O-Ring .....	1	10
	25	202334	Piston, Outer .....	1	-
	26	220005	Spring .....	1	-
	27	202290	Shaft .....	1	-
	28	NAS1351C04-4	Screw .....	6	-
	29	5720-158-25	Washer, Bronze .....	2	-
	30	5610-381-50	Washer, Teflon .....	1	-
	31-35	Left intentionally blank			
	36	AN565AC624H8	Set Screw .....	1	-



**Table 5.0**  
Torque Specifications 64505 & 64515

Fig.	Item	Part Number	Description	Torque in.-lb.
3 or 4	14	GF16997-32L	Screw(s).....	18 ± 2 in.-lb. (21 ± 2 kg-cm)
3 or 4	16	38NST188	Nut(s).....	195 ± 10 in.-lb. (225 ± 12 kg-cm)

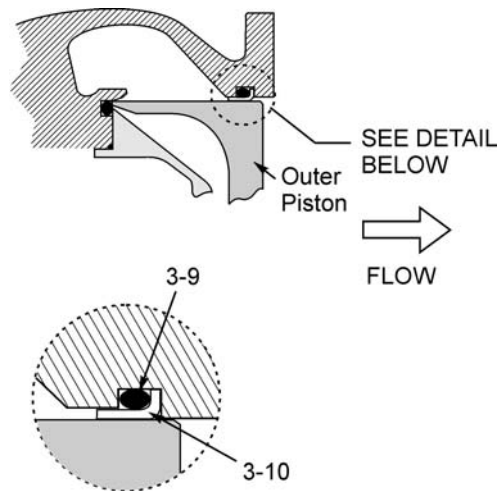
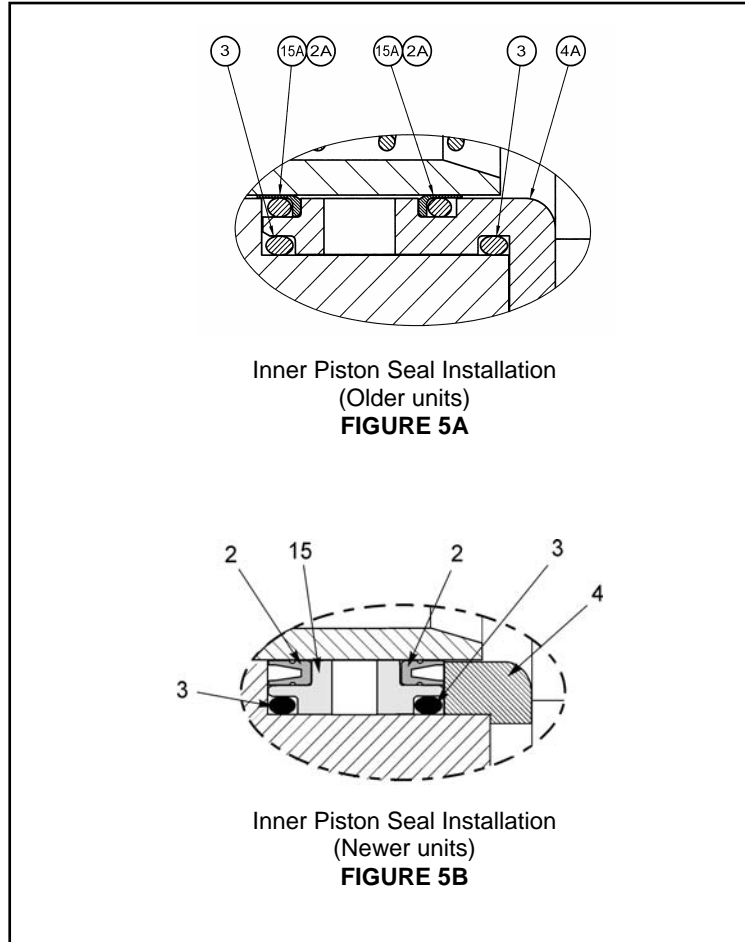

**FIGURE 6**

Outer Piston Seal Installation

Aerospace Group  
Conveyance Systems Division  
9650 Jeronimo Rd  
Irvine, CA 92618  
Ph (949) 452-9500  
Fax (949) 452-9992



*Powering Business Worldwide*