

## LABORATORY AND FIELD TRIAL EXPERIENCES WITH A SMART MV/LV SUBSTATION

Erik C.W. DE JONG  
KEMA- the Netherlands  
Erik.deJong@kema.com

Irina MELNIK  
Alliander – the Netherlands  
Irina.Melnik@alliander.com

Jan BOZELIE  
Alliander – the Netherlands  
Jan.Bozelie@alliander.com

Dmytro MALYNA  
Exendis B.V. – the Netherlands  
d.malyna@exendis.com

Ben J. WARGERS  
IMTECH VONK – the Netherlands  
ben.wargers@imtech.nl

Gerard SCHOONENBERG  
EATON Electric – the Netherlands  
GerardSchoonenberg@eaton.com

Josco C.P. KESTER  
ECN Intelligent Energy Grids – the Netherlands  
kester@ecn.nl

### ABSTRACT

It is expected that the power flow in low-voltage (LV) and medium-voltage (MV) distribution grids will start to fluctuate significantly in the near future due to the increasing penetration of dispersed generation within LV grids together with the global rise in energy demand (due to rising population and major electrification, for example). To manage these fluctuations while maintaining, or even improving, power quality and reliability, a smart substation has been developed by a Dutch consortium. A full-scale prototype of this substation has been assembled and its functionality validated by performing both laboratory and field trial testing. This paper highlights the most promising results of the laboratory tests, as well as from the half year field trial and the experience gained from the testing thus far.

### INTRODUCTION

Kester, et al. [1] introduced a smart MV/LV substation concept, intended to manage power fluctuations due to increased penetration of dispersed generation within MV and LV distribution grids [2].

This particular development has steadily progressed since then resulting in the realisation of a full-scale prototype (see Figure 1-Figure 3). An extensive range of laboratory tests was performed before it was commissioned in June 2010 as part of an existing low-voltage (LV) grid in Apeldoorn, the Netherlands (owned by the Dutch grid-operator: Alliander), for a prolonged field trial.



Figure 1 Medium-Voltage cubicle



Figure 2 Low-Voltage cubicle

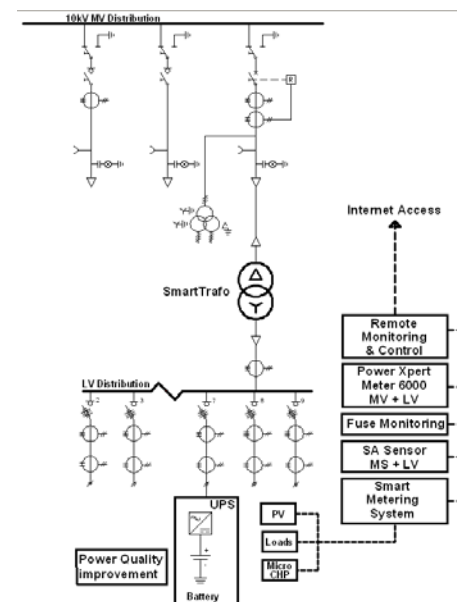

Figure 3 Electrical circuit diagram

The smart substation combines state-of-the-art power electronics together with advanced communications and optimisation software to optimise energy use and trading.

This paper reports on the experience gained from the laboratory tests, as well as from the half year field trial. Furthermore, it highlights the most promising results obtained throughout the extensive range of testing.

### LABORATORY TESTING

The Flex Power Grid Lab – a medium-voltage power electronic laboratory [5],[6] situated at KEMA (Arnhem, NL) – provided the ideal conditions to develop and verify:

- The system integration amongst individual components (hardware and software debugging),
- The MV and LV grid interface (interface protection, anti-islanding, etc.)
- The power quality (PQ) improvement measures (LV regulation, resistive harmonic damping [3][4], dip compensation and flicker mitigation)
- The ancillary services (demand response, energy storage, peak shaving),
- Estimate the achievable robustness,
- Estimate the achievable reliability.

All tests were performed at full power rating on the full-scale prototype (Figure 4).



Figure 4 Smart substation in front of FPGLab

The laboratory testing has shown that the integrated system provides a reliable substation for power distribution with the potential for integrated smart functionality such as voltage control, resistive harmonic damping (Figure 5), and active power control. Even the ability to sustain an island grid has been indicated.

Figure 5 shows the influence of the resistive harmonic damping (RHD) algorithm (implemented within the energy storage inverter – ESI – system) on both the LV spectrum (top left insert) as well as the active filter current spectrum (top right insert). Improvements of ~3% THD are indicated.

Furthermore, the tests demonstrated that:

- The smart substation functions properly and autonomously with no failures, correct voltage and current waveforms and correct operation of all internal circuits under the various specified test conditions.
  - The voltage and currents stresses, especially during adverse power quality conditions, are within the capabilities of the individual sub-assembly components and other internal circuits.
  - The cooling provided is adequate and no component is overheated, even under the worst temperature and operating conditions.
  - The protection characteristic is maintained despite the effect of temperature and adverse operating conditions, in particular loss of monitoring and control functionality.
- The acceptance criteria for the performed tests are aligned with those prescribed in the prevailing (inter)national standards for distribution stations and equipment.

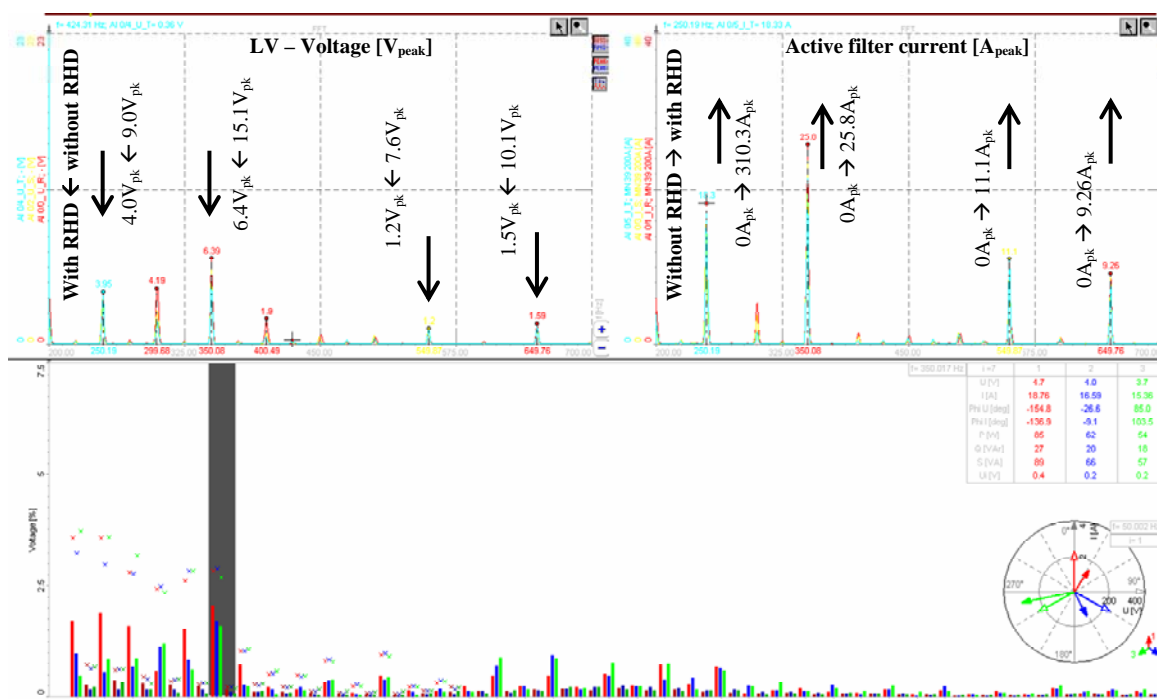

Figure 5 RHD performance on LV with superimposed MV harmonic voltages: 5<sup>th</sup>:1.6%; 7<sup>th</sup>:1.9%; 11<sup>th</sup>:0.7%; 13<sup>th</sup>:0.6%

**FIELD TRIALS**

In June 2010 the smart substation (Figure 6) was placed in the Alliander network with a high penetration of LV connected renewable and distributed energy sources (Figure 7).



**Figure 6 Substation on field trial location**

The field test design included a control group of connected customers to verify the influence of the smart substation on the consumers with and without local generation.

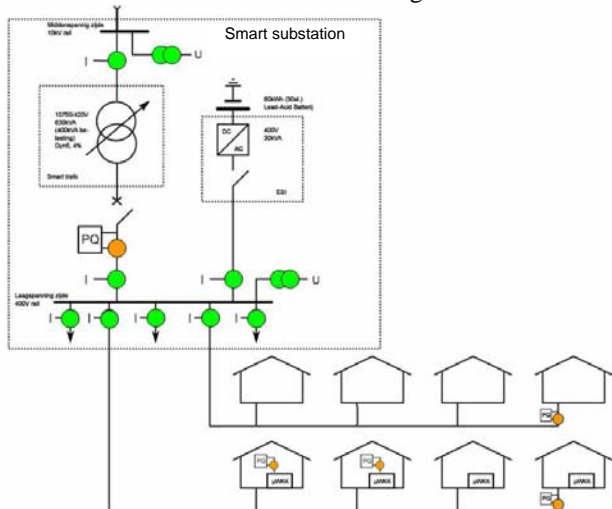

**Figure 7 Schematic diagram of field test connection**

The capability of the substation to influence the power flows, power quality (Figure 8) and to get management-ready information about the status of the substation and the connected customer's installations was continuously measured and analysed on a regular basis. To indicate the individual contribution of each smart substation feature only one provided feature was activated for a period of one week and compared to the measured system performance and grid condition of the base-case scenario (without any MV/LV station features active). This was performed for all features individually and thereafter with a combination of features active simultaneously until all features were active.

The recorded data is represented using the 'ABCDEF' power quality classification [7], indicating the quality of the LV network with respect to the following PQ phenomena (Figure 8-Figure 9):

- Voltage variations
- Voltage dips
- Frequency
- Flicker
- Harmonic voltage distortion (THD)

Each measurement period (in this case one week) is represented by a single dot at the appropriate power quality level as it has been measured.

A	Very high quality
B	high quality
C	Acceptable quality
D	Poor quality
E	Very poor quality
F	Extremely poor quality

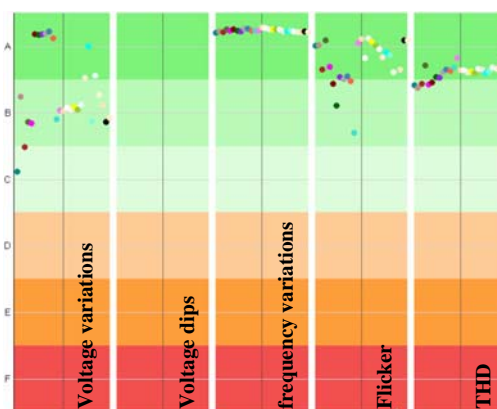

**Figure 8 LV measurement results – PQ events**

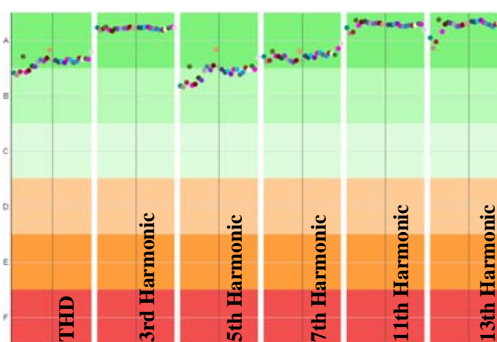

**Figure 9 LV measurement results - Harmonics**

Figure 8 indicates that the smart substation is capable of increasing the power quality with respect to voltage variations, flicker quality and to a lesser extent THD. For these power quality aspects the improvement is indicated from level B to level A. No voltage dip has been identified during the measurement period up to date, resulting in no result to show for this power quality aspect. Also frequency variations were not affected by the smart substation.

Notwithstanding that the overall THD quality of the grid is already quite good, Figure 9 indicates an incremental improvement of the THD, mostly by the RHD on the 5<sup>th</sup> and 7<sup>th</sup> harmonics.

## CONCLUSIONS

From the laboratory tests it can be concluded that:

1. The smart substation has shown its capability to manage fluctuations in power flow whilst maintaining some aspects of power quality and reliability of supply.
2. The smart substation is safe for operation as a replacement of a traditional substation in a public grid when operating in basic distribution-station mode (only providing bulk power).

From the field trials it can be concluded that:

1. The smart substation is capable of improving the power quality of the LV grid.
2. The smart substation is reliable in terms of power distribution with zero outages in the field trials up to date (period of 7 months).

## Acknowledgements

The authors wish to thank Agentschap NL and the Dutch ministry of Economic Affairs for their financial contribution to the project, under the IOP-EMVT-program.

## REFERENCES

- [1] Kester, J.C.P., et al, 2009, "A smart MV/LV-station that improves power quality, reliability and substation load profile", *CIRED, 20th international conference on electricity distribution*, Prague, Czech republic, 8-11 June 2009
- [2] [www.smartsubstation.eu](http://www.smartsubstation.eu)
- [3] H. Akagi, (Tokyo Institute of Technology, Japan), "New trends in active power line conditioners", *IEEE Trans. on Ind. Appl.* vol. 32.
- [4] W.R. Ryckaert et al, 2005, *Reduction of the Voltage Distortion with a Converter Employed as Shunt Harmonic Impedance*, IEEE.
- [5] E.C.W. de Jong, E.M. de Meulemeester, P.J.M. Heskes, 2008, "Design and realisation of a unique MV converter implemented in a new power electronic equipment test laboratory for emerging MV applications", *Proceedings Power and Energy Society General Meeting - Conversion and Delivery of Electrical Energy in the 21st Century*, IEEE, 1-4
- [6] [www.FlexPowerGridLab.com](http://www.FlexPowerGridLab.com)
- [7] J.F.G. Cobben, Power Quality – Implications at the point of Connection, Doctoral Thesis, 12 June 2007