



Harmonic Analysis and IEEE 1992 Guidelines

Application Note

New Information
April 2007

Harmonic Analysis and IEEE 1992 Guidelines

IEEE 519-1992 provides guidelines for applying limits to the level of harmonic distortion that a utility customer may inject into the power system. This is a concern, since Adjustable Frequency Drives (AFDs) can contribute significant harmonic distortion to a power system. The guidelines pertain to percent harmonic current and voltage distortion at the point of common coupling (PCC), which is defined as the point where the utility connects to multiple customers.

Although many customers and system designers interpret the PCC to be at the AFD input or various locations within the 480V distribution, this is not consistent with the intent of IEEE guidelines. There are no limits recommended for individual loads, only for the overall system. Customers and system designers can choose the point of analysis (POA) where they desire, but it may add substantial filtering costs if the POA is downstream of the PCC.

Current distortion drawn through an impedance (transformer, cable resistance) causes voltage distortion. The distorted current will also cause additional heating of the input cables and the transformer. Excessive voltage distortion is a concern, since it may cause interference with other electronic equipment and additional motor heating.

Table 1. Harmonic Current Distortion Limits (I_h and TDD) in % of I_L (≤ 69 kV)

I_{SC}/I_L Ratio	$I_h \leq 11$	$11 \leq I_h < 17$	$17 \leq I_h < 23$	$23 \leq I_h < 35$	TDD
<20	4.0	2.0	1.5	0.6	5.0
20 – 50	7.0	3.5	2.5	1.0	8.0
50 – 100	10.0	4.5	4.0	1.5	12.0
100 – 1000	12.0	5.5	5.0	2.0	15.0
> 1000	15.0	7.0	6.0	2.5	20.0

IEEE 519-1992 recommends different limits on Individual Harmonics (I_h) and Total Demand Distortion (TDD), depending on the I_{SC}/I_L ratio. I_{SC} is the short circuit current at the PCC, and I_L is the maximum demand load current (fundamental) at the PCC. More current distortion is allowed at higher I_{SC}/I_L ratios, since voltage distortion decreases as the ratio increases.

The voltage distortion guidelines for IEEE-1992 (at 480V) remain the same as IEEE 519-1981:

- 3% — Special systems (i.e. hospitals or universities)
- 5% — General systems
- 10% — Dedicated systems (AFDs only)

The best way to estimate AFD harmonic contribution to an electrical system is to perform a harmonic analysis based on known system characteristics. An individual AFD may meet the IEEE guidelines in one system and not meet the guidelines in another system depending on the pre-existing characteristics of the specific system.

Some AFD vendors, upon seeing a specification requirement for IEEE 519-1992, will simply add a line reactor. This is the wrong approach, since some systems will not require a line reactor and others will not benefit sufficiently to meet the guidelines (or the specification).

For a free computerized harmonic analysis of AFD contribution to system harmonics or for additional information, contact your local Cutler-Hammer® sales office. A one-line drawing of the electrical distribution system and specification criteria will be required. A harmonic analysis worksheet for required data is attached.

Any additional harmonic mitigation equipment requirements will be determined during the analysis. If there are harmonic constraints during AFD operation on a standby generator, a separate analysis will be required for the generator, and assumptions on load-shedding strategies during generator operation should be provided. Several data runs may be required to evaluate various harmonic mitigation methods. Resultant recommendations may include 1%, 3%, or 5% line reactors, phase-shifting transformers, filters, or CPX9000 Clean Power.

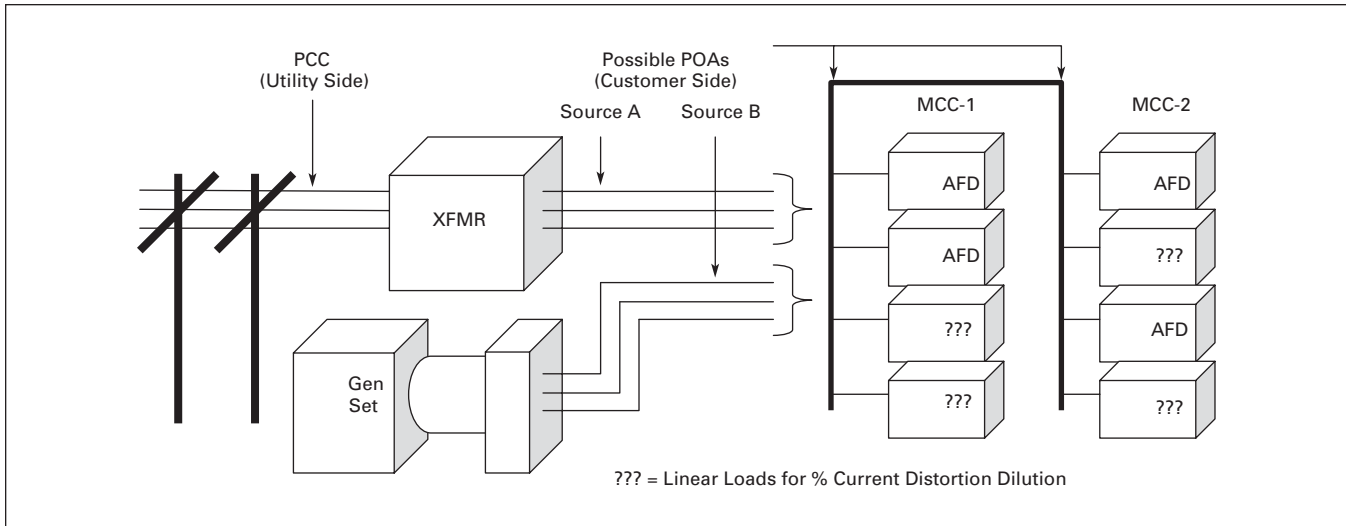

Figure 1. One Line Diagram

Helpful Facts

- Harmonics are supply system dependent. As the short circuit amps available (SCA) increase, % voltage distortion decreases, and % current distortion increases.
- For each PCC or POA analysis required, provide SCA and I_L (load current) values for that point. SCAs used must be without motor contribution to SCA.
- Current distortion percentages are dependent on overall system loading. As linear loads (non-harmonic loads such as AC motors on line power) increase, the percent current distortion decreases through dilution.
- % current distortion is the same across a transformer. Voltage distortion percentage is lower on the primary than on the secondary, assuming the harmonic loads are on the secondary.
- A harmonic analysis is only as accurate as the assumptions made for the analysis!

Harmonic Analysis Data Worksheet

(Use separate sheets if necessary. Provide a 1-line drawing or sketch.)

Customer/Project Name as it should appear on analysis	GO # or Negotiation #

Specification Requirements:

<input type="checkbox"/> IEEE519-1981 (Voltage Only) <input type="checkbox"/> IEEE519-1992 (Most Recentt)	Voltage Distortion: <input type="checkbox"/> 3% (Special) <input type="checkbox"/> 5% (General) <input type="checkbox"/> 10% (Dedicated)	Other Requirements:
--	---	---------------------

PCC and POA (Point of Analysis) Information:

(Show equipment and analysis points on 1-Line Diagram)

Location	Voltage	Maximum Load Current (I _L) (All Loads)	Short Circuit Amps (SCA) ① (Not including motor contribution)
PCC			
POA #1			
POA #2			

① If SCA (without motor contribution) is not provided, infinite SCA will be assumed on primary of distribution transformer. This will result in lower calculated voltage distortion and higher calculated current distortion on the transformer secondary.

Distribution Transformer(s) Data:

kVA	Impedance	X/R Ratio
#1		
#2		

- Tie Breakers Normally Open
- Tie Breakers Normally Closed

Generator Data:

kW	kVA	Volts	X"d	I _L (amps)
#1				
#2				

Describe load-shedding scheme for generator operation in "AFD Data" below.

AFD Data:

AFD hp	Type (SVX9000, Clean Power, etc.)	Quantity Operated on Line / Generator	Desired, existing or specified line reactor or isolation transformer (none, 1% / 3% / 5%)
		/	
		/	
		/	
		/	
		/	
		/	

Eaton Corporation
Electrical Group
1000 Cherrington Parkway
Moon Township, PA 15108
United States
877-ETN CARE (877-386-2273)
Eaton.com



Cutler-Hammer

© 2007 Eaton Corporation
All Rights Reserved
Printed in USA
Publication No. AP04014002E/CPG
April 2007