

# CLOGGING INDICATOR

## Series OP (visual), OE (visual-electrical)

Sheet No.  
**1614 G**

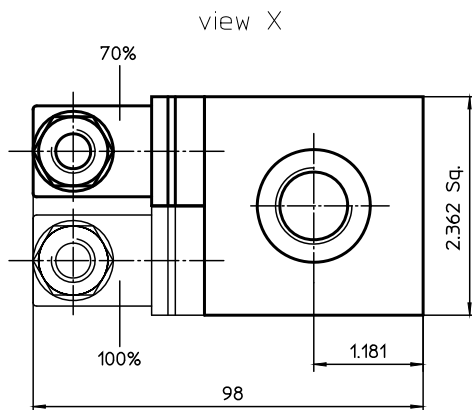
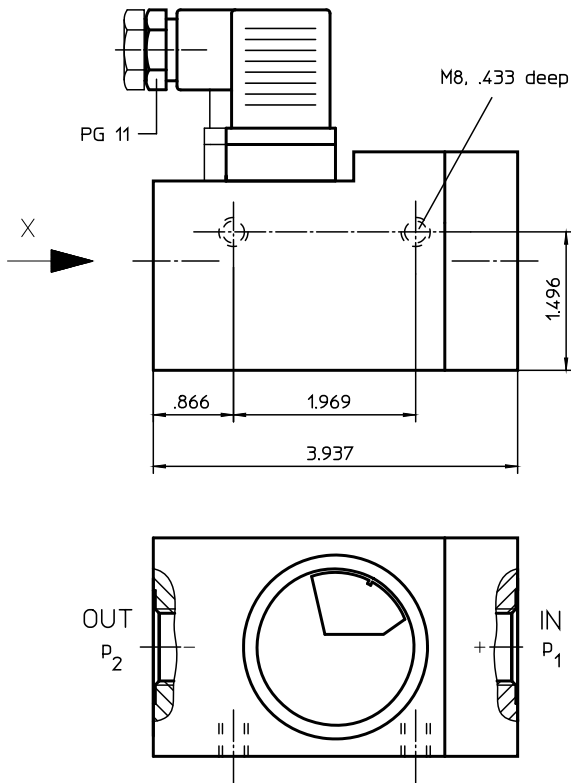

## 1. Clogging indicator OP-OE

### 1.1. Type index: (ordering example)

**OE1. 1.2. G. 1. P. -. 1**

1	2	3	4	5	6	7
---	---	---	---	---	---	---

#### 1 series:

- OE1 = clogging indicator, visual-electrical with 1 contact maker and contact breaker with 70% switching pressure difference
- OE2 = clogging indicator, visual-electrical with 1 contact maker and contact breaker with 70% and 100% switching pressure difference
- OP = clogging indicator, visual (according to series OE without switching contacts)

#### 2 indicator-pressure difference: $\Delta p$ -nominal

- 0,8 = 12 PSI; 2,5 = 36 PSI;
- 1,2 = 17 PSI; 4,5 = 65 PSI
- 1,5 = 22 PSI;

#### 3 connection:

- G = thread connection

#### 4 connection size:

- 1 = 1/4 BSPP
- 3 = 1/2 BSPP

#### 5 sealing material:

- P = Nitrile (NBR)      V = Viton (FPM)

#### 6 material:

- = standard
- VA = stainless steel

#### 7 execution:

- = without switching contacts (OP)
- 1 = execution 1 (electrical limit facts see item 3)
- 2 = execution 2 (electrical limit facts see item 3)

## 2. Technical data:

- permissible operating pressure: 914 PSI
- permissible operating temperature: +176°F
- permissible pressure difference:  $p_1 - p_2 \leq 232$  PSI
- indicator-pressure difference: 12; 17; 36; 65 PSI

The electrical signal takes place at 70% of the switching pressure difference using the design with two contacts the second signal takes place at 100% of the switching pressure difference.

## 3. Electrical limit facts:

- execution 1: 175V DC, 0,5A, 10 VA
- (CSA, UL licensed) 125V AC, 0,5A, 10 Watt
- execution 2: 1...230V, 1A, 20 Watt
- switch-over contact: contact maker and contact breaker
- protection: IP 65

## 4. Schematic diagramm:

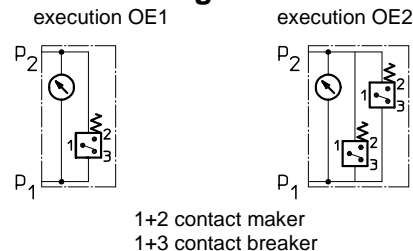

EDV 05/17

Changes of measures and design are subject to alteration!

## 5. Functioning:

The clogging indicator OE is a combined visual and electrical pressure difference indicator.

This type of pressure difference indicator can be mounted on all pressure filters with operating pressure  $\leq 914$  PSI, if the corresponding measuring ports on the filter housing are available.

With contamination of the filter element the difference between the supply pressure and the output pressure of the filter is increasing. Depending on this pressure difference but independent of the operating pressure, visual and electrical signals are released.

A pressure difference dependent measuring piston, charged with supply pressure and output pressure, moves towards a measuring spring.

Concerning the OE1 a permanent magnet which is integrated in the measuring piston switches - depending on the gauge length - a Reed-contact (magnetic-switch) and releases electrical control signals upon reaching a pressure difference of 70%.

The OE2 is equipped with two magnetic switches which release electrical control signals in a sequence of 70% and 100% of the switching pressure.

The visual control signal is indicated by a blue-red scale which is connected to the magnetic measuring piston.

In the range of low pressure differences - depending on the gauge length of the measuring piston - the blue range of the scale appears first.

The indicated switching pressure difference is reached when the dividing line between the red and the blue range of the scale points to the marking on the display window.

## 6. Operating instruction:

- Connection

Upon connecting the indicator to the filter make sure that the connection marked „+“ is connected to the dirt oil side (IN) and the connection marked „-“ is connected to the clean oil side (OUT).

**Note:** Consider data and connecting conditions mentioned in items 2 to 4.

## 7. Maintenance:

The device is maintenance-free. However, make sure that no solvents get in touch with the display window visual indicator nor with the piston-spring-system of the clogging indicator.