

Supersedes SA 199
 pages 1-12, dated January 1996

David D. Roybal, P.E.
 Cutler-Hammer
 Fellow Application Engineer

Automatic Transfer Switches

A Performance Comparison — Molded Case Switch Versus Contactor Type

Table of Contents	Page
About the Author	1
Part I: Abstract	1
Part II: "Circuit Breaker" Versus "Contactor" Design Transfer Switches . . .	1
Part III: Time-Current Coordination . . .	3
Part IV: Transfer Switch Performance During a Fault . . .	5
Part V: Conclusions	8
Part VI: References	8

About the Author

David D. Roybal received the Bachelor of Science degree in electrical engineering from Santa Clara University, Santa Clara, California, in 1969.

He is a Fellow Application Engineer with Cutler-Hammer in Lafayette, California. He previously was an engineer with Westinghouse for more than 24 years.

Mr. Roybal is a Senior Member of the Institute of Electrical and Electronics Engineers (IEEE) and presently an officer of the San Francisco Chapter of the Industry Applications Society.

He is a member of the National Fire Protection Association (NFPA), the National Society of Professional Engineers (NSPE), the International Association of Electrical Inspectors (IAEI), and the NEMA California Safety Regulations Advisory Committee. He is a registered professional engineer in the State of California. The Westinghouse Board of Directors awarded him the Westinghouse Order of Merit in 1993. He was a recipient of the IEEE Third Millennium Medal in the year 2000.

Part I: Abstract

Molded case switch type automatic transfer switches with trip units and "contactor" type automatic transfer switches protected by circuit breakers perform equally for various fault conditions. High withstand molded case switch type automatic transfer switches without trip units perform exactly as "contactor" type automatic transfer switches, except that "contactor" type designs have limited withstand capabilities. Such "contactor" type designs have potential problems in applications with upstream power circuit breakers having short delay trip characteristics.

Part II: "Circuit Breaker" Versus "Contactor" Design Transfer Switches

A transfer switch is a device for transferring one or more load conductor connections from one power source to another.^① Many engineers believe that there are two types of transfer switch designs, "contactor" designs and "circuit breaker" designs. There are indeed two different design concepts, but this terminology is misleading. "Contactor" type transfer switches do not use motor starting/lighting contactors, and "circuit breaker" type transfer switches do not use circuit breakers.

Contactors are NEMA devices designed for motor starting and lighting control which are capable of high endurance (long-life switching capabilities). Their no-load and full-load mechanical operations can number in the millions. They can be electrically held or mechanically held devices. Electrically held devices will drop out upon loss of control voltage. A typical application is as part of a motor starter. Mechanically held devices have mechanical latches or designs which inherently remain closed upon loss of control voltage. A typical

application for mechanically held devices is for lighting control, where using a latched device allows a user to avoid having to reset all contactors after a utility outage.

Transfer switches are also capable of high endurance, but not nearly as great as that of a motor starting/lighting contactor. UL 1008 defines the minimum endurance of a transfer switch. This is detailed in **Table 1**. Both "contactor" and "circuit breaker" designs meet these minimum UL 1008 requirements as evidenced by their UL label. Some transfer switch manufacturers may publish endurance capabilities in excess of these minimums, especially for the larger ampacity units.

Transfer switches known as "contactor" designs do not use motor starting/lighting type contactors. Rather, "contactor" type transfer switches — along with "circuit breaker" type transfer switches — in fact use circuit breaker design contacts, arc chutes, and arcing horns. Moreover, most "contactor" type transfer switch manufacturers purchase these parts from manufacturers of circuit breakers. Thus "contactor" type transfer switches actually owe their design more to circuit breaker technology than to contactor technology.

Transfer switches known as "circuit breaker" type use specially designed switching devices that are typically molded case switches; circuit breakers are an option. The contacts, arc chutes, and arcing horns are completely enclosed in an insulated housing, as they were originally designed to be. The switching devices themselves are further required to meet UL 1087 (Molded Case Switches) or UL 489 (Molded Case Circuit Breakers) requirements, as well as UL 1008 (Automatic Transfer Switches) requirements. This means that "circuit breaker" type transfer switches are

Table 1 — ATS Endurance (UL 1008 Table 30.2)

Switch Ampere Rating	Rate of Operation	Number of Cycles of Operations		
		With Current	Without Current	Total
0-300	1 per minute	6000	—	6000
301-400	1 per minute	4000	—	4000
401-800	1 per minute	2000	1000	3000
801-1600	1 per 2 minutes	1500	1500	3000
1601 and above	1 per 4 minutes	1000	2000	3000

① NEMA ICS 10-1993, AC Automatic Transfer Switches.

held to a more rigorous testing standard than “contactor” type switches. The main contact assemblies in “circuit breaker” type transfer switches are subject to periodic UL 489 and UL 1087 follow-up testing versus the one-time-only UL 1008 design test for “contactor” type automatic transfer switches. Typically, the switching devices in a “circuit breaker” type transfer switch are oversized for the ampacity of the transfer switch. For example, an 800 ampere “circuit breaker” type transfer switch uses 1200 ampere switching devices, as shown in **Table 2**. Thus the contacts used in a “circuit breaker” type transfer switch are likely to be larger than the contacts used in a “contactor” type of equal rating because of this oversizing.

There are actually two types of “circuit breaker” transfer switch designs: those using molded case switches with over-

current protection and those using molded case switches without over-current protection. Smaller ampacity designs use molded case switches with fixed instantaneous trip units set high to allow the maximum withstand of the device. Other molded case switches, such as the Cutler-Hammer Type SPB Insulated Case Switch, can be provided without trip units. These are switches that have extremely high withstand and endurance ratings, often greater than those of a comparable “contactor” type switch. Typical ratings are shown in **Table 3**. As an alternate design, the transfer switches can be provided with molded case switches having overcurrent and ground fault trip units. These are used where integral over-current protection is desired, such as in service entrance applications.

Since “contactor” type transfer switches do not use contactors and both “contactor” and “circuit breaker” type automatic transfer switches use circuit breaker parts, what is their difference in performance? Under most downstream fault conditions, both designs will perform identically, i.e., the upstream breaker will trip and the switch logic will initiate the transfer sequence to the alternate source.

“Contactor” type transfer switches and “circuit breaker” type transfer switches using molded case switches without trip units perform identically under all circumstances. However, it should be noted that these “circuit breaker” type transfer switch designs

normally have much higher withstand and endurance ratings than the “contactor” type transfer switches.

“Contactor” type transfer switches and “circuit breaker” type transfer switches using molded case switches with instantaneous trip elements perform identically when applied in systems with molded case circuit breakers.

When the upstream breaker is a power circuit breaker with no instantaneous trip element, it may have a short delay time setting for coordination with other devices under high fault conditions. When a downstream fault occurs, the power circuit breaker can delay tripping in order to allow the downstream device to selectively clear the fault.

If the power circuit breaker short delay time setting is set high, fault current may flow in excess of the limited time and current withstand ratings of a “contactor” type transfer switch. A “circuit breaker” type transfer switch using molded case switches without trip units can be selected to withstand the short delay time, while a transfer switch design using molded case switches with instantaneous trip elements would merely trip and reset. In some situations the high-magnitude fault may cause a drop in voltage which could initiate a transfer sequence for either the “contactor” type transfer switch or the “circuit breaker” type transfer switch. When this occurs, the transfer switch will attempt to interrupt the fault current. The engineer may find that the limited

Table 2 — Molded Case Switch ATS With Instantaneous Trip Elements

UL 1008 Switch Ampere Rating	UL 1087/UL 489 Cutler-Hammer Molded Case Frame	UL 1087/UL 489 Frame Ampacity
100	F	150
150	K	225
150	K	400
225	K	400
300	K	400
400	L	600
600	M	800
800	N	1200
1000	N	1200

Table 3 — Transfer Switch Withstand Ratings (Time and Current)

Transfer Switch Ampere Rating	UL 1008 3 Cycle Rating					Extended Rating		
	Cutler-Hammer Transfer Switch with Molded Case Switches ^①	Cutler-Hammer Transfer Switch with Type SPB Switches ^②	Manufacturer “A” Transfer Switch ^①	Manufacturer “R” Transfer Switch ^①	Manufacturer “Z” Transfer Switch ^①	Cutler-Hammer Transfer Switch with Type SPB Switches ^②	Manufacturer “R” Transfer Switch ^①	Manufacturer “A” Transfer Switch ^①
30/40	65 kA	N/A	10 kA ^③	N/A	10 kA ^③	N/A	N/A	N/A
70/80	65 kA	N/A	10 kA ^③	N/A	10 kA ^③	N/A	N/A	N/A
100	65 kA	N/A	10 kA ^③	42 kA	10 kA ^③	N/A	N/A	N/A
150	65 kA	N/A	10 kA ^③	42 kA	10 kA ^③	N/A	N/A	N/A
225/260	65 kA	N/A	35 kA	42 kA	35 kA	N/A	40 kA 10 cycles	N/A
300	65 kA	N/A	N/A	N/A	35 kA	N/A	N/A	N/A
400	65 kA	N/A	35 kA	42 kA	35 kA	35 kA ^④ 60 cycles	40 kA 10 cycles	N/A
600	50 kA ^⑤	100 kA	50 kA	65 kA	50 kA	35 kA ^④ 60 cycles	40 kA 10 cycles	N/A
800	50 kA ^⑤	100 kA	50 kA	65 kA	50 kA	35 kA ^④ 60 cycles	40 kA 10 cycles	N/A
1000	50 kA ^⑤	100 kA	85 kA	85 kA	50 kA	35 kA ^④ 60 cycles	50 kA 10 cycles	65 kA 30 cycles
1200	N/A	100 kA	85 kA	85 kA	50 kA	35 kA ^④ 60 cycles	50 kA 10 cycles	65 kA 30 cycles
1600	N/A	100 kA	100 kA	100 kA	100 kA	51 kA 60 cycles	50 kA 10 cycles	65 kA 30 cycles
2000	N/A	100 kA	100 kA	100 kA	100 kA	51 kA 60 cycles	N/A	65 kA 30 cycles
3000	N/A	100 kA	100 kA	100 kA	100 kA	51 kA 60 cycles	N/A	65 kA 30 cycles
4000	N/A	100 kA	100 kA	100 kA	100 kA	85 kA 60 cycles	N/A	65 kA 30 cycles

① Symmetrical rms amperes at 480 volts and 20% short circuit power factor (X/R ratio of 4.9).

② Symmetrical rms amperes at 480 volts and 15% short circuit power factor. Power circuit

breakers are tested at a more severe 15% short circuit power factor (X/R ratio of 6.6) which results in a higher fault duty.

③ 1.5 cycles only.

④ Also available with a rating of 51 kA at 60 cycles.

⑤ Contact Cutler-Hammer for availability.

⑥ 4-pole units rated 35 kA.

interrupting rating of “contactor” type transfer switches is not adequate for the system design and may select the self-protecting “circuit breaker” type design instead. The use of “contactor” type transfer switches in these cases would be a misapplication.

The electrical engineer must determine which design characteristics are preferable based on the system requirements and the performance of the transfer switch to be applied. This paper provides information that can be used in making that choice.

Part III: Time-Current Coordination

To better understand the operation of molded case switches used in transfer switch applications, it is necessary to review their time-current characteristics and their coordination with other devices in a power distribution system. Molded case circuit breakers are available with both thermal-magnetic and solid state trip units. Typically, smaller molded case circuit breaker frame sizes are provided with thermal-magnetic trip units and larger frame sizes (approximately 400 amperes and above) are provided with solid state trip units.

Examining a typical circuit breaker time-current curve, we can discuss the protection provided by the various portions of the curve. **Figure 1** shows a time-current curve for an adjustable instantaneous thermal-magnetic molded case circuit breaker. The long time portion of the curve provides overload protection for the circuit, while the instantaneous portion provides short circuit protection. The long time response is usually provided by a thermal element where the delay is in seconds, with shorter time delays as the current increases. This “inverse-time” characteristic is typical of thermal-magnetic breakers. The instantaneous pickup is normally adjustable for frames rated 225 amperes and higher. Since instantaneous elements operate with no intentional time delay, only the magnitude of the fault current determines which circuit protective devices in series will trip.

Figure 2 shows the time-current curve adjustments for a solid state trip unit with adjustable phase current settings. The long time pickup and delay provide overload protection. The short time pickup and delay are adjusted to coordinate with other circuit breakers and to allow acceptable overloads, such as motor or transformer inrushes, to occur without tripping the circuit breaker. The instantaneous portion of the curve protects against high-magnitude faults such as short circuits.

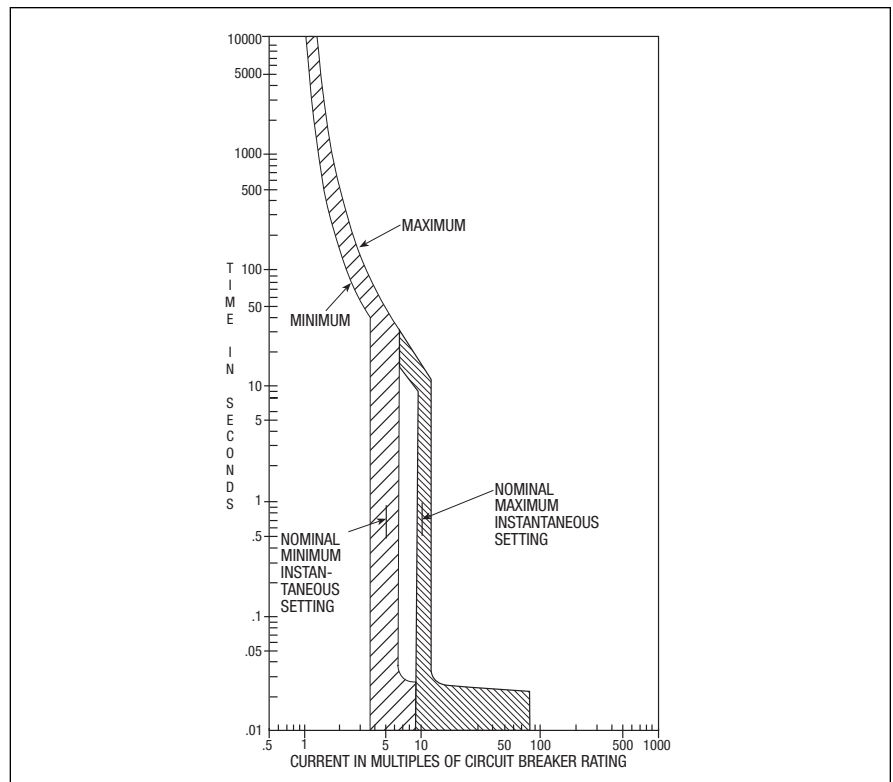

Figure 1 — Typical Time-Current Curve for Adjustable Instantaneous Thermal-Magnetic Molded Case Circuit Breakers (NEMA AB3)

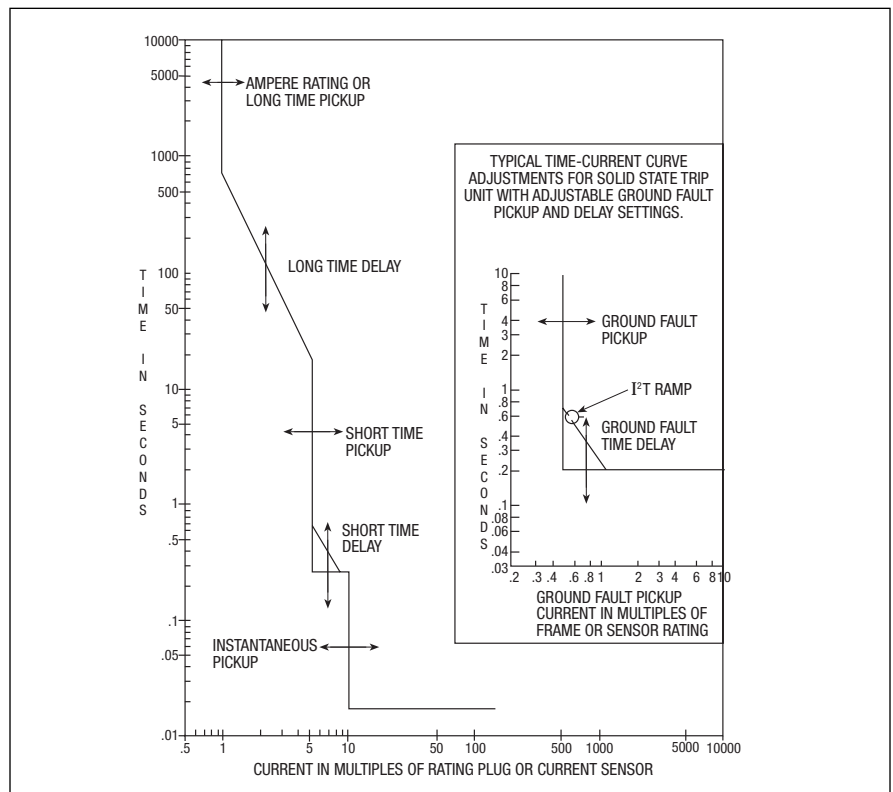

Figure 2 — Typical Time-Current Curve for Solid State Trip Unit with Adjustable Phase Current Settings (NEMA AB3)

In many power system designs where devices with high withstand ratings are available, the instantaneous trip is deleted in order to achieve improved coordination. Instantaneous trips set below the available fault current cannot be fully coordinated because the magnitude of the fault current cannot be controlled. All breakers in series with instantaneous trips respond to the fault current and try to clear the fault with no intentional time delay. Typically, time delay is used to allow devices to selectively coordinate.

All molded case circuit breakers are designed to NEMA standards and have instantaneous trips. Typically, the maximum setting is 10 to 13 times the frame rating. Special designs — called insulated case circuit breakers by the industry — such as the Cutler-Hammer Type SPB Insulated Case Breaker, may have higher than normal instantaneous settings. These designs allow use of the short time pickup and delay to achieve improved coordination and selectivity.

Power circuit breakers are designed to ANSI standards, and their interrupting rating equals their short time rating. This means that they can be applied without instantaneous trip elements to achieve true coordination between devices. A typical power circuit breaker is the Cutler-Hammer Magnum DS. Its interrupting and short time ratings are shown in **Table 4**. Power circuit breakers allow the engineer the most flexibility in designing a truly coordinated system. Both the power circuit breaker and the switchgear that incorporates it are designed and tested to withstand, without damage, the high magnitude fault currents that flow through the equipment for up to 30 cycles.

Current limiting breakers as well as switches with current limiting fuses can substantially reduce the available fault current. Fuses selectively coordinate when devices in series are selected in ratios that allow the downstream fuse to clear for a given current before the melting level of the upstream fuse is reached.

An overcurrent in a power system can occur as a result of normal conditions such as motor inrush during starting or transformer inrush upon energization. It can also occur as a result of abnormal conditions such as overloads, short circuits, or ground faults. The circuit protective devices in a system sense abnormal conditions and protect against them by opening the power circuit. In a properly designed system, they will have been chosen to operate selectively to protect equipment, property,

and personnel, while minimizing the outage of the remainder of the system.

During the design of the power distribution system, the various protective devices are evaluated in a series circuit from the power source to the load. The object is to localize the power interruption so that the device closest

to the fault is the first to clear it. Each upstream circuit protective device has the backup capability to isolate and clear the fault in the event of the misoperation or nonoperation of the downstream device, so that the damage to the faulted circuit and the effect of the disturbance on the rest of the power distribution system are minimized.

Table 4 — Electrical Characteristics of Magnum DS Power Circuit Breakers

Magnum DS Model	Frame Size	Trip Ampere Range	UL Listed Interrupting Capacity at 480 Volts rms Symmetrical Amperes (kA)	
			With Instantaneous Trip	Without Instantaneous Trip (30 cycle maximum delay)
MDS-408	800	80 – 800	42	42
MDS-608	800	80 – 800	65	65
MDS-808	800	80 – 800	85	85
MDS-C08	800	80 – 800	100	85
MDS-616	1600	80 – 1600	65	65
MDS-816	1600	80 – 1600	85	85
MDS-C16	1600	80 – 1600	100	85
MDS-620	2000	80 – 2000	65	65
MDS-820	2000	80 – 2000	85	85
MDS-C20	2000	80 – 2000	100	85
MDS-632	3200	1000 – 3200	65	65
MDS-832	3200	1000 – 3200	85	85
MDS-C32	3200	1000 – 3200	100	85
MDS-840	4000	1280 – 4000	85	85
MDS-C40	4000	1280 – 4000	100	100
MDS-850	5000	1280 – 5000	85	85
MDS-C50	5000	1280 – 5000	100	100

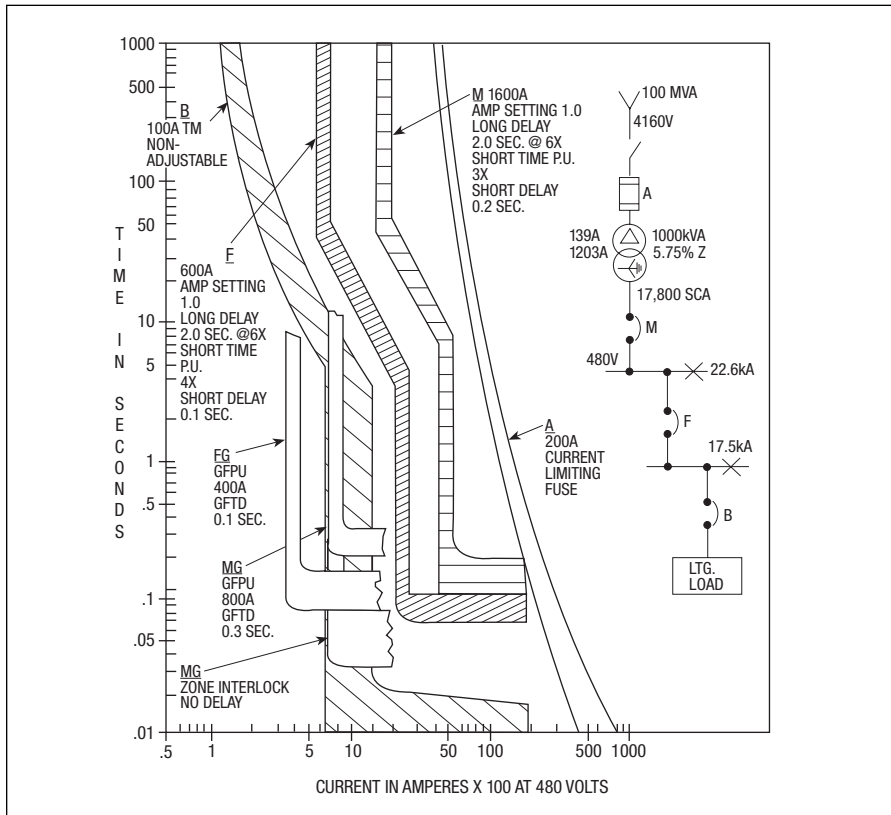

Figure 3 — Typical System — Selectively Coordinated (NEMA AB3)

The time-current coordination of a power system is normally evaluated on a log-log plot of time versus current. Manufacturers provide time-current curves for their circuit breakers, and the engineer plots the appropriate device, with the chosen adjustments and indicated operating limits, to reflect its operation in the power system. Also included

on the time-current coordination curve are a one-line diagram showing all the protective devices, their interconnection, and the major distribution or utilization apparatus (motors, generators, transformers, etc.); indication of the available fault current at important points in the power system; inrush and damage characteristics of motors and transformers; and other appropriate information.

A typical example of time-current coordination is shown in **Figure 3**. The 100 ampere circuit breaker B protects the load and the load conductors and selectively coordinates with upstream devices for overload and short circuit conditions. Selective coordination for low level ground faults on branch circuit B is not possible since circuit breaker B is not provided with ground protection. Circuit breaker F is rated 600 amperes and selectively coordinates with upstream and downstream devices. Circuit breaker M is the 1600 ampere main breaker and coordinates with the downstream circuit breaker F as well as with the 200 ampere primary fuse A for all faults on the load side of the circuit breaker. The primary fuse provides short circuit protection for the transformer, while the secondary main breaker provides the overload protection.

Part IV: Transfer Switch Performance During a Fault

Proper power system design requires consideration of both normal and abnormal operating conditions. Normal operating conditions require consideration of system voltage, load flow, effects of motor starting, service continuity, and reliability. Abnormal conditions require consideration of system and apparatus protection and minimization of service interruption.

Several types of faults are possible: 3-phase bolted faults, phase-to-phase faults, double line-to-ground faults, single line-to-ground faults, line-to-neutral faults, and so on.

Three types of operating conditions are typically evaluated for purposes of equipment protection and system operation: overloads, short circuits, and ground faults. Both overloads and short circuits involve currents in excess of

rated operating current. Overloads are usually low level and cause thermal damage. Short circuits are usually high level, with the only limiting factors being the source kVA and the circuit impedance. The damage due to short circuits can be catastrophic. Ground faults are currents that flow through an unintended path (ground). They require special consideration because they are the most common type of fault and may be below the operating level of the protective device ampacity or may quickly increase to a higher level. All three types of faults can cause damage, but each has unique characteristics that must be addressed.

“Contactor” type transfer switches subjected to a fault are designed to remain in the position they were in prior to the fault unless the fault conditions cause the voltage-sensing relays to operate. “Circuit breaker” type transfer switches using high withstand molded case switches without instantaneous trip elements, such as the Type SPB Insulated Case Switch, perform identically to “contactor” type transfer switches. They also remain in the position they were in prior to a fault. An alternate “circuit breaker” type transfer switch design, using molded case switches that contain high instantaneous trip elements, will trip if the fault is downstream and of sufficient magnitude. At this point the transfer switch will seek the next available power source, with the normal source being the preferred source. Note, however, that during such a high-magnitude fault the upstream protective device will also trip, causing any type of transfer switch to operate. This occurs whether the

transfer switch is a “circuit breaker” type or a “contactor” type, with either design yielding the same end result.

Faulted Source

As shown in **Figure 4**, with either design of transfer switch when the fault (F1) is on the normal source (line) side of the switch, the upstream circuit breaker (CB1) will trip. If this occurs, there is a loss of the voltage source to the switch and the transfer sequence is initiated. If the alternate source is a generator, the generator will be given a start signal. When the voltage and frequency of that source are within an acceptable range, the switch will transfer the load. In this case there is no difference in performance between the “contactor” and “circuit breaker” type transfer switches.

Overload

When the system problem is an overload, the performance of both designs of transfer switch is again identical. Neither transfer switch design inherently has overload protection, although this feature can be provided as a design option in a “circuit breaker” type transfer switch. For an overload of the transfer switch circuit (F2), the upstream circuit protective device (CB1) will trip and the switch will respond to the power outage by transferring to an alternate source when available. If the overload is downstream on one of the emergency feeders (F3), the corresponding feeder breaker (CB2) will trip and the load will be shed. Typically, no transfer of the switch occurs with either design.

Ground Fault

When the system problem is a ground fault, the performance of both designs of transfer switch is once again identical. The only exception is when a high-magnitude ground fault (F3) occurs downstream of a “circuit breaker” type transfer switch with instantaneous trip elements. In this case, the system disturbance is similar to that of a short circuit (described below), yielding the same end result for either design of switch. But, in general, ground faults are low-level faults because of the high impedance of the ground return circuit. This is why special relaying is provided to sense and protect against ground faults. If an upstream device (CB1) trips due to a ground fault (F1 or F2), the switch will respond to the power outage by transferring to the alternate source when available. If the ground fault is downstream (F3) and one of the emergency feeders (CB2) trips, the load will be shed. Typically, no transfer of the switch occurs with either design.

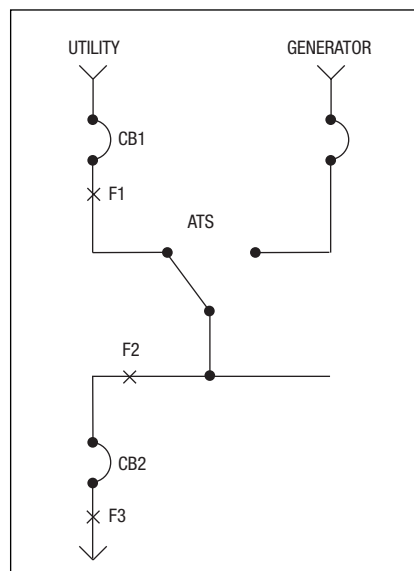

Figure 4 — ATS Response to Faults

Short Circuit

The only system disturbance in which “contactor” and “circuit breaker” type transfer switches may differ in response is a high-magnitude downstream fault (short circuit) when the “circuit breaker” type switch contains instantaneous trip elements. If the “circuit breaker” type transfer switch uses molded case switches without instantaneous trip elements (for example, the Type SPB Insulated Case Switch), there is no difference in performance from that of a “contactor” type transfer switch.

For a high-magnitude downstream fault, a “contactor” design transfer switch does not change operating position unless signaled by the under-voltage relays. Upstream of the transfer switch is a power circuit breaker, molded case circuit breaker (CB1), or fused switch protecting the transfer switch and downstream circuit. The upstream device has an overload trip rating sized to protect the ampacity of the transfer switch. If the upstream device opens, the transfer switch will sense a loss of voltage and initiate a transfer.

Short Circuit: Upstream Breaker (CB1) With Instantaneous Trip Elements

Let us first consider the situation where the upstream power circuit breaker or molded case circuit breaker feeding the transfer switch has an instantaneous trip. In general, circuit breaker instantaneous trip elements that are adjustable have an adjustment range of five to 10 times the overload trip rating. Molded case switches with nonadjustable instantaneous trip elements are designed to trip at approximately 10 to 13 times the frame rating. Lower-magnitude overcurrent conditions are protected by other trip elements (long time, short time, and ground fault) of the upstream or downstream circuit breaker after a time delay. The instantaneous trip elements act with no intentional time delay and cause an immediate outage of the circuit when the device opens. This means that if the short circuit fault current magnitude is below the instantaneous trip setting of the device (CB1) feeding the transfer switch, the downstream circuit breaker (CB2) should clear the fault and no loss of power to the switch should occur. If the magnitude of the fault current is above the instantaneous trip setting of the device (CB1) feeding the transfer switch, both the downstream circuit breaker (CB2) and the upstream circuit breaker (CB1) will trip. At this point the transfer

switch senses a loss of voltage and initiates a transfer to the alternate source. Because the downstream breaker has cleared the fault, a normal transfer occurs. When the normal supply is restored, the transfer switch returns to the normal supply. The key point to note is that the transfer switch operates only for a downstream fault in excess of about 10 times the switch rating.

Let us examine a “circuit breaker” type transfer switch under such a disturbance (high-magnitude downstream fault) and follow its performance. As mentioned previously, there are two designs of “circuit breaker” type transfer switches. The first are devices with no instantaneous trip elements, such as the type SPB design. These are switches with extremely high withstand ratings, and they perform exactly the same as the “contactor” type switch for all operating conditions. The second type uses circuit breakers classified as molded case switches. These have nonadjustable instantaneous trip elements set at 10 to 13 times the frame rating of the device. To meet the UL requirements for transfer switches, the molded case switches are sized approximately one size larger than expected. For instance, an 800 ampere transfer switch uses 1200 ampere molded case switches, as shown in **Table 2**. This means that the

instantaneous trip setting is much higher than that of the upstream breaker (CB1) protecting the transfer switch, as seen in **Figure 5**. If the magnitude of the downstream fault current (F3) is above the instantaneous setting of the upstream breaker (CB1) and below the instantaneous setting of the molded case switch in the transfer switch, the “circuit breaker” type transfer switch will operate in the same manner as described above for the “contactor” type transfer switch.

If the magnitude of the downstream fault current (F3) is above the instantaneous trip setting of both the upstream breaker (CB1) and the molded case switch in the “circuit breaker” type transfer switch, both devices will open, along with the downstream breaker (CB2). The transfer switch will be in a position with both switches open. There is no power source available on the normal side, since the upstream normal source breaker (CB1) has tripped. At this point both a “contactor” type transfer switch and a “circuit breaker” type transfer switch sense a loss of voltage, start the generator, and initiate a transfer sequence to the alternate source. When a “circuit breaker” type automatic transfer switch transfers to the alternate source, it automatically resets the normal switch from the tripped-open position to the normal-open position.

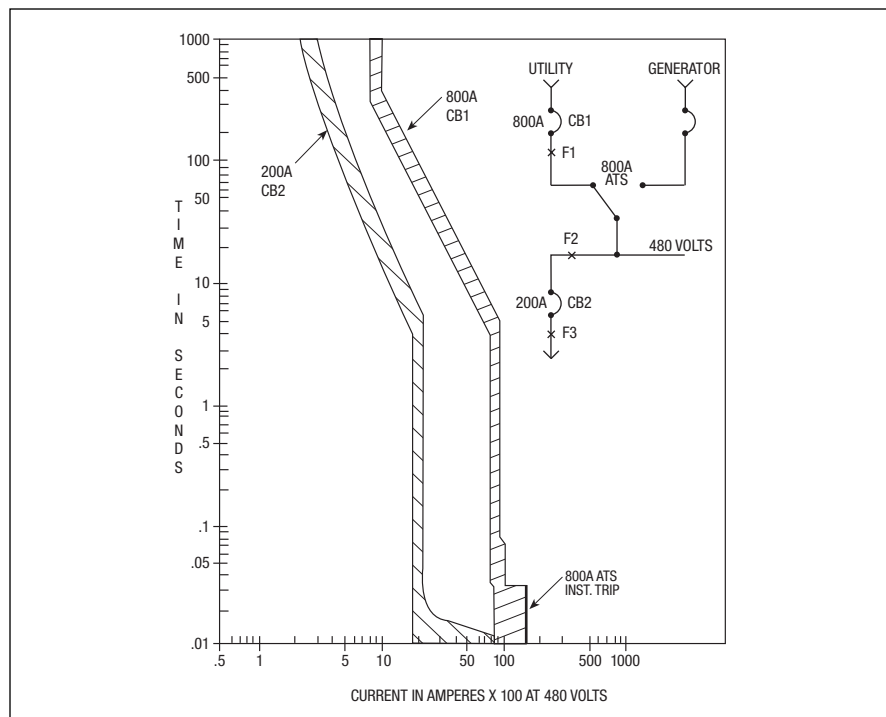

Figure 5 — System Response to Downstream Overcurrent at F3

Since the downstream breaker has cleared the fault, a normal transfer occurs. When the normal supply is restored, both designs of transfer switch return to the normal supply. Note that under the above circumstances the same end result occurs with a “contactor” type switch and a “circuit breaker” type switch. The transfer switch operated only for a downstream fault in excess of about 10 times the switch rating. Both the upstream and downstream devices opened, causing the transfer switch to initiate a transfer sequence. A summary of this discussion is shown in **Table 5** and **Table 6**.

Short Circuit: Upstream Breaker (CB1) Without Instantaneous Trip Elements and With Short Time Delay

Let us now consider the situation where the upstream device is a power circuit breaker with no instantaneous trip element or an insulated case circuit breaker with a high fixed instantaneous trip setting above the available fault current. These devices have exceptionally high withstand ratings with short delay time capabilities of up to 30 cycles.

Withstand ratings indicate the ability of a device to withstand the available fault current without damage. They are normally expressed as a function of time, because the device must withstand the fault current until the fault is cleared. For a passive device, such as cable, the fault is cleared by an external operation. This may be the opening of an upstream or downstream circuit breaker or fuse. The fault may also be cleared by the failure of the power source or by some other means. For an active device, such as an instantaneous trip circuit breaker, the withstand rating is the same as the interrupting rating since the circuit breaker is intended to clear the fault with no intentional delay. Some circuit breakers, such as ANSI rated power circuit breakers and some insulated case circuit breakers, have extended time withstand ratings. This allows them to selectively coordinate while other devices clear the fault. Products applied in electrical systems have withstand ratings associated with their design or the standards applicable to the product. Withstand ratings for each product are expressed in time and current.

Interrupting ratings indicate the ability of a device to safely interrupt fault current. Some devices, such as circuit breakers, are inherently designed to interrupt current and thus have high interrupting ratings. Other devices, such as contactors, are not normally

Table 5 — ATS Response to Faults

Location of Disturbance	Type of Disturbance	CB1 Response	CB2 Response	Instantaneous Trip Molded Case Switch ATS Response	SPB ATS Response	Contactor Type ATS Response
F1	Overload	Trip	No Change	Start Generator Transfer	Start Generator Transfer	Start Generator Transfer
	Short Circuit	Trip	No Change	Start Generator Transfer	Start Generator Transfer	Start Generator Transfer
	Ground Fault	Trip	No Change	Start Generator Transfer	Start Generator Transfer	Start Generator Transfer
F2	Overload	Trip	No Change	Start Generator Transfer	Start Generator Transfer	Start Generator Transfer
	Short Circuit	Trip	No Change	Start Generator Transfer	Start Generator Transfer	Start Generator Transfer
	Ground Fault	Trip	No Change	Start Generator Transfer	Start Generator Transfer	Start Generator Transfer
F3	Overload	No Change	Trip	No Transfer	No Transfer	No Transfer
	Short Circuit (Low Magnitude)	No Change	Trip	No Transfer	No Transfer	No Transfer
	Short Circuit (High Magnitude)	Trip ^①	Trip	Start Generator Transfer	Start Generator Transfer	Start Generator Transfer
	Ground Fault (Low Magnitude)	No Change	Trip	No Transfer	No Transfer	No Transfer
	Ground Fault (High Magnitude)	Trip ^{①②}	Trip	Start Generator Transfer	Start Generator Transfer	Start Generator Transfer

① Does not trip if it is a power circuit breaker with no instantaneous trip.
② Operates instantaneous pickup of molded case circuit breaker CB1.

Table 6 — Transfer Switch Response to Downstream Overcurrent at F3 (Figure 5)

Current Amperes	CB2 Response	CB1 Response	Molded Case Switch Type ATS Response	Contactor Type ATS Response
100	No Change	No Change	No Transfer	No Transfer
500 1,000 2,500 5,000	Trip	No Change	No Transfer	No Transfer
10,000 15,000	Trip	Trip	Transfer	Transfer

Note: CB1 — 800 ampere molded case breaker feeding the transfer switch
CB2 — 200 ampere molded case breaker fed by the transfer switch
ATS — 800 ampere transfer switch
F3 — Fault on load side of CB2

expected to interrupt fault current and generally have low interrupting ratings. Contactors are designed to interrupt load current and locked rotor current. For example, in a combination motor starter, the motor circuit protector or fused switch provides the short circuit protection by interrupting

the fault. The overload relay provides overload protection by opening the contactor. The contactor normally interrupts only motor load current. Its interrupting rating, based on its ability to interrupt fault current, is extremely low, typically 5000 amperes for a smaller contactor.

Automatic transfer switches have published withstand and interrupting ratings that must be complied with for safe application. Their application requires an understanding of the operation of other devices in the system that can affect their ability to safely withstand or interrupt faults. For instance, if an upstream power circuit breaker is applied with a setting utilizing the withstand capabilities of the device (short delay time with no instantaneous trip elements), the transfer switch must be rated for the fault current that the device will allow to flow. This application of power circuit breakers is common in health care facilities and data centers, where continuity of service is paramount. Circuit protective devices without instantaneous trip elements are applied to achieve coordination. The ANSI standards for the power circuit breakers and switchgear ensure that this is a safe and appropriate application.

In these cases, the withstand rating of transfer switches must be carefully considered. In fact, the 3-cycle minimum withstand required by the UL 1008 standard may not be adequate for a given application. In such cases, "circuit breaker" type transfer switch designs offer some unique advantages because of their inherent interrupting capability and consequent withstand rating.

Some circuit breaker designs, such as the Cutler-Hammer Type SPB Insulated Case Breaker, are available as molded case switches without trip units (nonautomatic switches) and have extremely high withstand ratings. The SPB Insulated Case Switch is available with the ratings shown in **Table 3** and is applied in transfer switch designs having those same ratings. These 60 cycle withstand ratings allow proper application of the transfer switch in high-magnitude fault applications with upstream power circuit breakers.

Other "circuit breaker" type transfer switch designs have molded case switches with instantaneous trip elements and are inherently self-protecting. They can also be safely applied in systems with upstream power circuit breakers that have extended short time delays.

"Contactor" type transfer switch designs must therefore be carefully applied in systems with upstream power circuit breakers. Their use should be considered only when either (a) the upstream power circuit breaker has instantaneous trip elements and

the fault current is within the published rating of the transfer switch or (b) the short delay time of the upstream power circuit breaker can be set low enough to protect the "contactor" design transfer switch within its withstand rating.

Part V: Conclusions

In all the scenarios described above — overloads, ground faults, and short circuits — "circuit breaker" type transfer switches and "contactor" type transfer switches perform equally. However, the performance of "circuit breaker" type transfer switches is typically superior for applications with upstream power circuit breakers.

"Circuit breaker" type transfer switches can be provided with overcurrent and ground fault trip elements in a variety of configurations. They can be service entrance labeled and are available in fixed mounted or drawout construction. When the power switching devices are provided with integral overcurrent protection, they can be used in the power system for feeder protection, often eliminating the need for upstream breakers feeding the switch. For safety purposes, this option is provided with a lock-out function that prevents further automatic transfer operation until the appropriate source is manually reset.

Part VI: References

*NEMA ICS 10
Industrial Control and Systems
AC Transfer Switch Equipment*
National Electrical Manufacturers Association
1300 North 17th Street, Suite 1847
Rosslyn, VA 22209

*NEMA AB3
Molded Case Circuit Breakers and
Their Application*
National Electrical Manufacturers Association
1300 North 17th Street, Suite 1847
Rosslyn, VA 22209

*UL 489
Molded Case Circuit Breakers and
Circuit Breaker Enclosures*
Underwriters Laboratories, Inc.
333 Pfingsten Road
Northbrook, IL 60062

*UL 1008
Automatic Transfer Switches*
Underwriters Laboratories, Inc.
333 Pfingsten Road
Northbrook, IL 60062

*UL 1087
Molded Case Switches*
Underwriters Laboratories, Inc.
333 Pfingsten Road
Northbrook, IL 60062

*ANSI/IEEE C37.16
Low Voltage Power Circuit Breakers
and AC Power Circuit Protectors —
Preferred Ratings, Related
Requirements, and Application
Recommendations*
Institute of Electrical and
Electronics Engineers
445 Hoes Lane
P.O. Box 1331
Piscataway, NJ 08855-1331

*Systems Pow-R-Breaker with
Digitrip RMS Trip Unit*
*Cutler-Hammer Descriptive
Bulletin 29-850*
Cutler-Hammer
1000 Cherrington Parkway
Moon Township, PA 15108-4312

*Transfer Switch Equipment
Cutler-Hammer Technical Data 29-925*
Cutler-Hammer
1000 Cherrington Parkway
Moon Township, PA 15108-4312

Zenith Bulletin O-5064-1, 1993
Zenith Controls, Inc.
830 West 40th Street
Chicago, IL 60609

*Withstand and Closing Ratings for
Transfer Switch Equipment*
*ASCO Engineering Application
Information*
Automatic Switch Company
50-60 Hanover Road
Florham Park, NJ 07932

*Russelectric Automatic Transfer
Switches
Type RMT, 1993*
Russelectric Inc.
South Shore Industrial Park
Hingham, MA 02043

Russelectric Engineering Newsletter 478
Russelectric Inc.
South Shore Industrial Park
Hingham, MA 02043

© 2001 Eaton Corporation,
All Rights Reserved

