

Free #674

Transfer Switches Applied in Systems with Power Circuit Breakers

David D. Roybal, P.E.
Senior Member, IEEE
Cutler-Hammer
3697 Mount Diablo Boulevard
Lafayette, CA 94549
USA

Abstract – This paper is an overview of the industry standards for short-time current ratings of low-voltage transfer switches and power circuit breakers. It defines and compares the standard withstand and closing ratings of transfer switches and the short-time current rating of power circuit breakers. It reviews a typical distribution system using transfer switches and power circuit breakers to demonstrate the need to consider switches with extended short-time current ratings for such applications.

I. INTRODUCTION

Electrical distribution systems often use transfer switches to automatically select power from utility (or commercial) sources and emergency (or standby) sources. In order to be selectively coordinated, these distribution systems may require the application of switchgear using power circuit breakers with short-time-delay trip elements and no instantaneous trip element. A device with short-time current ratings can safely remain closed for a specified time interval under high fault conditions.

Power circuit breaker short-time current ratings, often referred to as withstand ratings, are defined in the standards of the American National Standards Institute (ANSI). Industry-defined withstand ratings for transfer switches are defined in Underwriters Laboratories (UL) and National Electrical Manufacturers Association (NEMA) standards; however, engineers need to clearly understand the definition of these ratings in order to apply them properly. The standard short-time current rating of a transfer switch may be inadequate for the system design, and the specification of an extended rating may be necessary. Performance differences in the withstand capabilities of each product can lead to a misapplication of transfer switches in systems with power circuit breakers.

This paper discusses the difference in the short-time ratings of transfer switches and power circuit breakers as well as recently proposed changes regarding the standards for automatic transfer switches. It also describes a typical distribution system having power circuit breakers with short-time current ratings. This example demonstrates the need for the application of transfer switches with extended short-time current ratings.

II. TRANSFER SWITCHES

Transfer switches are switching devices for transferring one or more load conductor connections from one power source to another [1]. A transfer switch may be automatic (self-acting) or nonautomatic (manual). UL defines an automatic transfer switch as a device that automatically transfers a common load from a normal supply to an alternate supply in the event of failure of the normal supply and automatically returns the load to the normal supply when the normal supply is restored [2]. If not self-protecting, transfer switches require protection by upstream overcurrent protective devices.

Transfer switches are critical for reliable power and are applied in emergency and standby systems. Emergency systems are those that meet the requirements of National Electrical Code (NEC) Articles 517 and 700 [3] and National Fire Protection Association NFPA 99 [4]. They are legally required to automatically supply alternate power, within ten seconds of power interruption, to a number of prescribed functions essential for the safety of human life. Legally required standby systems meet the requirements of NEC Article 701. These systems are intended to automatically supply power to selected loads (other than those classed as emergency systems) in the event of failure of the normal source. Optional standby systems meet the requirements of NEC Article 702. They are intended to supply power either automatically or nonautomatically to selected loads other than those classed as emergency or legally required standby. Transfer switches are used extensively in health care facilities, data centers, and other applications.

UL defines the test requirements for short-circuit current withstand and fault closing ratings of automatic transfer switches. The transfer switch must withstand the designated level of short-circuit current until the overcurrent protective devices open unless overcurrent protection is integral to the design. The test current is specified in terms of the required symmetrical amperes and the power factor of the test circuit. The test current is maintained for at least 3 cycles (50 ms), the standard short-time current rating for transfer switches. The same sample is used for the closing test, and the requirements are similar to those for the withstand test.

TABLE I
TRANSFER SWITCH TEST CIRCUIT POWER FACTOR REQUIREMENTS

Withstand and Closing Rating (rms symmetrical amperes)	UL 1008 Maximum Test Power Factor	NEMA Maximum Test Power Factor	Minimum Corresponding X/R Ratio
10,000 or less	0.40 - 0.50	0.50	1.73
10,001 - 20,000	0.25 - 0.30	0.30	3.18
Greater than 20,000	0.20 or less	0.20	4.90

TABLE II
TYPICAL TRANSFER SWITCH 3-CYCLE SHORT-CIRCUIT CURRENT WITHSTAND AND FAULT CLOSING RATINGS
FOR VARIOUS CONTINUOUS CURRENT RATINGS

Continuous Rating (amperes)	UL Standard Requirement (kA)	Switch A (kA)	Switch B (kA)	Switch C (kA)	Switch D (kA)
400	10	35	42	35	65
600	12	50	65	50	65
800	16	50	65	50	65
1000	20	65	85	50	65
1200	24	65	85	50	100
1600	32	100	100	100	100
2000	40	100	100	100	100
3000	60	100	100	100	100
4000	80	100	100	NA	100

Table I shows the UL and NEMA test circuit power factor requirements and corresponding X/R (reactance/resistance) ratios for the withstand and closing test current values. The minimum magnitude of the short-circuit test current is related to the switch continuous current rating. UL 1008 requires switches with a continuous current rating of 101 – 400 amperes to be tested for 3 cycles with a short circuit rms symmetrical current of 10,000 amperes. Switches 401 amperes and greater are tested for 3 cycles with a short circuit current 20 times their rating but not less than 10,000 amperes rms symmetrical. Manufacturers are allowed to test their designs with higher available short-circuit test current at their option. Table II shows typical transfer switch 3-cycle short-circuit current withstand and fault closing ratings available from the industry.

The overcurrent protective device may be (a) an integral circuit breaker provided in the transfer switch if the circuit breaker is part of the design, (b) the maximum-ampere-rated fuse that can be inserted if integral fuse holders are provided, or (c) an externally connected circuit breaker or fuse. If the short-circuit current rating of a transfer switch is dependent on the use of a specific overcurrent protective device (circuit breaker or fuse) ahead of the transfer switch, the transfer switch must be so marked.

The standard withstand ratings for transfer switches shown in Table II are 3-cycle ratings. In applications with line side circuit breakers having instantaneous trip elements, the

transfer switches are adequately protected, since the operating time of such circuit breakers is within the 3-cycle rating of the transfer switches. In applications with circuit breakers having short-time-delay trip elements and no instantaneous trip elements, the transfer switches may not be adequately protected if the time delay is beyond the transfer switch 3-cycle rating.

III. POWER CIRCUIT BREAKERS

The short-circuit current rating of a power circuit breaker is defined by its interrupting capacity, the maximum current the circuit breaker can safely interrupt. The interrupting capacities of most power circuit breakers without integral fuses range from 30 kA to 100 kA. The short-time current rating of a power circuit breaker defines the ability of the device to remain closed for a time interval under high fault current conditions. Most power circuit breaker short-time current ratings range from 35 kA to 85 kA. The preferred three-phase short-circuit current and short-time current ratings of power circuit breakers with and without instantaneous trip elements are defined in ANSI C37.16 [5].

The ANSI test standards for power circuit breakers require fault testing for a short-delay time of 30-cycle duration, followed by a 15-second zero current interval and another fault test for a short-delay time of 30-cycle duration. This short-time current capability is one of the main distinctions

between a molded case or insulated case circuit breaker and a power circuit breaker.

Short-time current ratings allow an upstream circuit breaker to remain closed and power flow to a distribution system to be maintained while a downstream circuit breaker clears a faulted circuit. This short-time current rating allows circuit breakers in series to be selectively coordinated.

Selective coordination may be sacrificed for current magnitudes in excess of the maximum short-time current rating when circuit breakers in series have instantaneous trip elements. All molded case and insulated case circuit breakers have instantaneous trip elements, although some insulated case circuit breakers also have high short-time current ratings that allow withstand ratings up to the limit of their instantaneous trip. Power circuit breakers are available with or without instantaneous trip elements. When power circuit breakers are applied without instantaneous trip elements, their short-time current rating is equivalent to their interrupting current rating, and their maximum short-delay time rating is 30 cycles.

IV. TEST POWER FACTOR (X/R)

Devices are tested at a short-circuit power factor based on their fault current rating and the type of device. Power factor, cosine θ , is a mathematical relationship between reactance (X) and resistance (R), so each test power factor has a specific corresponding test ratio X/R, or tangent θ . The lower the short-circuit test power factor, the higher the X/R ratio and the more demanding the test. X and R represent the total reactance and resistance from the faulted point in the system back to the generating source.

Unfused power circuit breakers are tested for a short-circuit power factor of 15% maximum, or an X/R ratio of 6.6. Transfer switches with a fault current rating of 20,000 amperes or greater are tested at a 20% power factor, corresponding to an X/R ratio of 4.90. For applications in systems with an X/R ratio in excess of 4.90, the transfer switch fault current rating should be reduced. Multiplying factors for adjusting the calculated short-circuit current can be found in ANSI C37.13 [6].

A typical asymmetrical current wave is shown in Fig. 1. The effect of reactance in an AC system is to cause the initial current to be high and then decay toward steady-state value. The initial asymmetrical waveform becomes symmetrical as the direct-current component of the fault current decays. The rate of decay depends on the X/R ratio of the circuit. For a 15% power factor, or an X/R ratio of 6.6, the first peak of the total current would be 2.3 times the first peak of the symmetrical current wave.

The higher the X/R ratio, the greater the first peak value of the short-circuit test current. The X/R ratio determines the degree of asymmetry in the faulted circuit, or the maximum

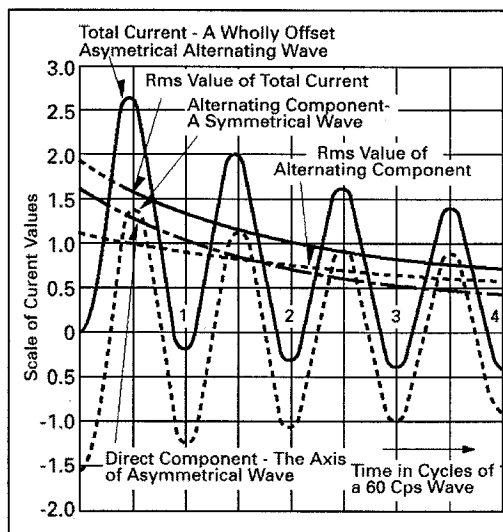

Fig. 1. Structure of an Asymmetrical Current Wave

value by which the first half-cycle peak current exceeds the steady-state rms value of the fault current. The maximum rms asymmetrical current is derived from the rms symmetrical current and the DC component at the fault current peak. The actual degree of asymmetry depends on when in the voltage wave the fault occurs.

V. SYSTEM COORDINATION AND SELECTIVITY

The coordination capabilities of some circuit breakers are limited by their instantaneous trip characteristics. For overloads and low-magnitude faults, the time and current settings of circuit breakers can be coordinated based on their specific adjustments and the available overcurrent. For high-magnitude faults, instantaneous trips generally cannot be coordinated, since there is no time delay for coordination purposes.

When power circuit breakers without an instantaneous trip element are provided, their short-delay current capability allows engineers to specify settings that are fully selective for applications with a high-magnitude fault current available.

A one-line diagram for a typical application for a transfer switch is shown in Fig. 2. A 4000-ampere power circuit breaker is the main circuit breaker for the utility source. A 1600-ampere power circuit breaker feeds a 1600-ampere automatic transfer switch used to provide power to the load either from the utility during normal operation, or from the generator upon loss of utility power. Molded case circuit breakers could be chosen for the 4000-ampere and 1600-ampere protective devices and would provide protection for the transfer switches; however, their instantaneous trip elements might inhibit their ability to selectively coordinate should a high-current fault occur. For system applications requiring full selectivity for all values of fault current, power circuit breakers are a better selection.

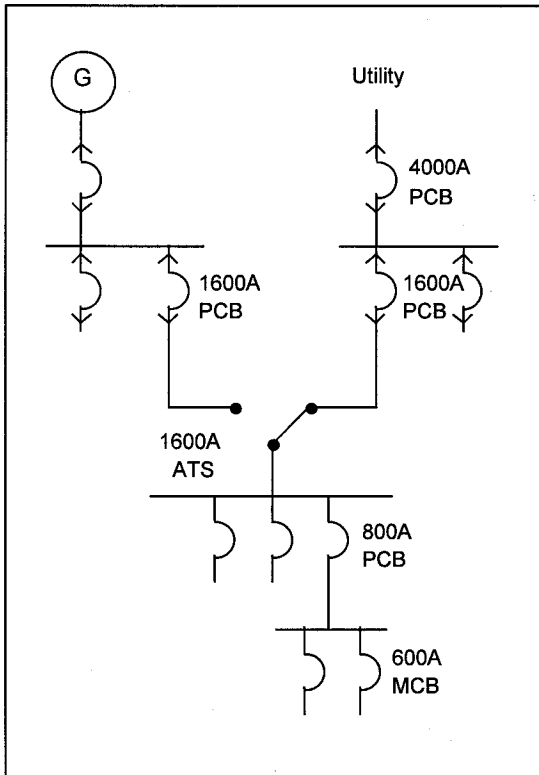

Fig. 2. System One-Line Diagram

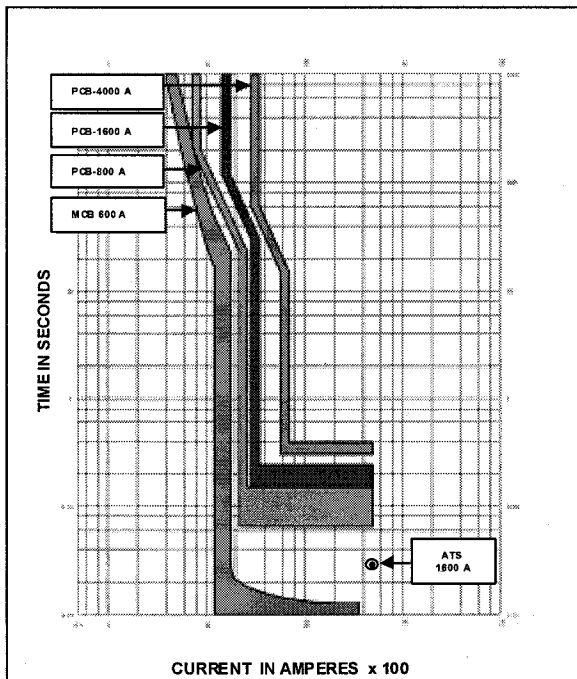

Fig. 3. System Time-Current Coordination

The time-current curves in Fig. 3 show the degree of coordination of the power circuit breakers and molded case circuit breakers for the distribution system in Fig. 2. The 4000-ampere main and 1600-ampere feeder power circuit breakers are fully selective, since there is time and current separation for the entire fault range between the circuit breaker response curves. Neither device has an instantaneous trip element, and the short-delay time and current settings of both devices coordinate up to the maximum available fault current of 50,000 amperes.

Likewise, the 800-ampere feeder power circuit breaker and the 600-ampere feeder molded case circuit breaker (which has an electronic trip unit) are fully selective for all values of fault current. Even though the molded case circuit breaker has an instantaneous trip, the absence of an instantaneous trip in the upstream power circuit breakers allows the devices to coordinate up to the maximum available fault current.

VI. SHORT-TIME-DELAY SETTINGS

The short-time-delay settings selected for the power circuit breaker trip units in the system in Fig. 2 are 0.4 second (24 cycles) for the main circuit breaker, 0.2 second (12 cycles) for the transfer switch feeder circuit breaker, and 0.1 second (6 cycles) for the downstream feeder circuit breaker. These settings are not uncommon for a system with multiple levels of power circuit breakers.

A transfer switch is selected for an application based on its voltage, continuous current, withstand, closing, and interrupting ratings. It is important to note that for transfer switches the standard withstand rating, as stated earlier in this paper, is only 3 cycles. If the transfer switch for the system

TABLE III
CIRCUIT BREAKER SETTINGS

4000 A PCB (Static Trip - LS)

Frame: 4000 A, Sensor: 4000
LTPU: 0.8 LTD: 2.0 sec.
STPU: 2.0 STD: 0.4 sec.
No Instantaneous Trip

1600 A PCB (Static Trip - LS)

Frame: 1600 A, Sensor: 1600
LTPU: 1.0 LTD: 4.0 sec.
STPU: 2.0 STD: 0.2 sec.
No Instantaneous Trip

800 A PCB (Static Trip - LS)

Frame: 800 A, Sensor: 800
LTPU: 1.0 LTD: 7.0 sec.
STPU: 3.0 STD: 0.1 sec.
No Instantaneous Trip

600 A MCB (Thermal-Magnetic, LI)

Frame: 600 A, Trip: 600 A
Instantaneous PU: $5 \cdot T = 3000$ A

shown in Fig. 2 were applied with a standard withstand rating, it would be protected by an upstream power circuit breaker with a 12-cycle short-time delay and no instantaneous trip element. This is a misapplication, since the switch must be protected within its 3-cycle short-time current rating. This system design requires a switch with an extended short-time current rating of at least 12 cycles. Switch designs with extended time withstand ratings up to 30 cycles are available. Which extended rating is appropriate depends on the system design and the protective device settings.

Many applications, such as health care facilities and data centers, use several transfer switches in their emergency or standby systems. The systems often have multiple levels of power circuit breakers, and settings of 6, 12, 18, 24, or 30 cycles are not uncommon for the trip unit short-time-delay pickup. The electrical engineer must determine which transfer switch design characteristics are necessary based on the system requirements and the performance of the transfer switch to be used.

It is also necessary to check that the transfer switch is rated for the available short-circuit current and short-circuit power factor, and thus the corresponding minimum X/R ratio, at the point of application. Because of their high withstand and closing ratings, most transfer switches have a test power factor of 20%, corresponding to an X/R ratio of 4.90. However, for applications in close proximity to generators, the X/R ratio of the available fault current may be 20 or greater, requiring the use of multiplying factors for derating both the circuit breakers and the transfer switches.

UL is presently considering proposed changes to the requirements of UL 1008 that would permit short-time current ratings for transfer and by-pass isolation switches. If adopted, this change, which addresses the need to coordinate systems, will allow manufacturers the option of adding a short-time current rating to products presently UL listed.

The proposed short-time tests would be performed at rated voltage and with an available short-time rms symmetrical current at the test source terminals not less than the short-time current rating of the transfer switch. Tests are performed at the test power factors indicated in Table I. The total length of the test circuit conductors could not exceed 8 feet (2.4 m) per conductor unless the excess length was included in the test circuit calibration. After the switch

passed the proposed UL test requirements, the manufacturer could label the switch with the marking "This transfer switch may be applied with an upstream circuit breaker having a short-time rating not exceeding ____ volts at ____ amperes, for ____ cycles (seconds)."

VII. CONCLUSIONS

The UL, NEMA, and ANSI standards provide industry test requirements for transfer switches and power circuit breakers. The short-time current ratings of standard-rated transfer switches assume that the upstream protection will clear the fault within 3 cycles (50 ms) and that the short-circuit power factor is at least 20%. On the other hand, short-time current ratings of power circuit breakers assume that the fault current can be maintained for as long as 30 cycles (500 ms) and that the short-circuit power factor could be as low as 15%.

For proper coordination at the different levels of protection in a system, it may be desirable to choose power circuit breakers without instantaneous trip elements for protection upstream of the transfer switch. In these applications it is necessary to choose a transfer switch capable of carrying the required short-circuit current for a time equal to the short-time delay setting of the upstream circuit breaker. This would certainly be longer than the standard 3-cycle transfer switch withstand test interval. Transfer switches should have a short-time current withstand capability equivalent to the rating of the upstream power circuit breaker so that no problem results if the short-time delay is set to 0.5 second.

REFERENCES

- [1] NEMA ICS 10-1993, *Industrial Control and Systems AC Transfer Switch Equipment*, Rosslyn, VA: NEMA.
- [2] UL 1008-1996, *Automatic Transfer Switches*, Northbrook, IL: UL.
- [3] NFPA 70, *1999 National Electrical Code*, Quincy, MA: NFPA.
- [4] NFPA 99, *Health Care Facilities*, Quincy, MA: NFPA.
- [5] ANSI C37.16-1997, *Low-Voltage Power Circuit Breakers and AC Power Circuit Protectors – Preferred Ratings, Related Requirements, and Application Recommendations*, Rosslyn, VA: NEMA.
- [6] ANSI/IEEE C37.13-1990, *IEEE Standard for Low-Voltage AC Power Circuit Breakers Used in Enclosures*, New York, NY: IEEE.