

**IntelliView™ Series  
Photoelectric Sensors**

**Contents**

Overview . . . . .	1
Model Selection, Sensors . . . . .	2
Model Selection, Cables . . . . .	6
Model Selection, Accessories . . . . .	7
Wiring Diagrams . . . . .	8
Dimensions . . . . .	9
Detection Diagrams . . . . .	11
Specifications . . . . .	13

The IntelliView Series from Eaton is a family of compact, high performance specialty photoelectric sensors designed to solve a wide array of sensing challenges.

IntelliView encompasses a variety of new sensing technologies: color, contrast and luminescence sensing; field-adjustable foreground and background suppression sensing; short-range distance sensing with analog outputs; and long-range, high-precision laser distance sensing with analog outputs.

To fit into your application, IntelliView sensors are available in industry-standard M18 flat-tubular and compact rectangular package sizes. For ease of installation and replacement, all models are available with micro connectors.

**Approvals**

- UL Listed
- C-UL Listed

CE

 Unless otherwise noted, the products contained in this document are not designed or intended for use in human safety applications.

**New Cutting-Edge Sensors Detect Color, Contrast, Luminescence and Distance with High Precision**



**Product Features**

- **New Sensing Technologies** — Now, Eaton has solutions for sensing color, contrast, luminescence and distance with great accuracy
- **Small Size, Big Solutions** — IntelliView sensors come in either compact rectangular or flat-tubular package sizes, both rugged sealed enclosures
- **Simple “Teach In” Installation** — Most models include a teach mode, allowing for quick and simple installation and setup
- **Adjustable Background Suppression** — For the first time, Eaton offers a fully field-adjustable background suppression photoelectric sensor capable of detecting targets as far as 3.9 ft. (1.9 m) away
- **LED Indicators and Pushbuttons** — Multiple LEDs communicate output and power status while built-in pushbuttons and adjustment potentiometers simplify the teaching of sensor settings
- **C-UL Listed and CE Approved** — Accepted worldwide

For Customer Service in the U.S. call **1-877-ETN CARE (386-2273)**,  
in Canada call **1-800-268-3578**.  
For Application Assistance in the U.S. and Canada  
call **1-800-426-9184**.

**Overview — Adjustable Foreground/Background Suppression Models**





- Ignores nuisance foreground or background objects
- Field-adjustable sensing ranges
- Compact 50x50mm rectangular package size
- M12 micro connector termination with 90- and 180-degree rotation options
- Sensing ranges up to 47.2 in. (120 cm)

**Foreground/Background Sensing Basics**

Foreground/background suppression sensors allow the user to precisely set the minimum and maximum detection distance. This allows detection of a target only when it is inside a given area, avoiding the interference of objects lying before (foreground) and behind

(background). This type of sensor is ideal for suppressing the detection of box edges and bottoms, sending an output only upon the presence of goods actually contained in the box.

**Model Selection — Adjustable Foreground/Background Suppression Selection**

	Voltage Range	Output Type	Connection	Adjustable Sensing Range	Catalog Number
<b>Background Suppression Models</b>					
	10 – 30V DC	Light Operate or Dark Operate (Selectable), PNP	4-Pin Micro Connector ①	3 – 10 cm (1.2 – 4.0 in.)	<b>E75-PPA010P-M12</b>
				3 – 25 cm (1.2 – 9.8 in.)	<b>E75-PPA025P-M12</b>
				10 – 50 cm (4.0 – 19.7 in.)	<b>E75-PPA050P-M12</b>
<b>Extended Range Background Suppression</b>					
	10 – 30V DC	Light Operate or Dark Operate (Selectable), PNP	4-Pin Micro Connector ①	6 – 120 cm (2.4 – 47.2 in.)	<b>E75-PP1MP-M12</b>
<b>Foreground/Background Suppression Models</b>					
	10 – 30V DC	Light Operate or Dark Operate (Selectable), PNP	4-Pin Micro Connector ①	Foreground: 5 – 20 cm (2.0 – 7.9 in.) Background: 12 – 110 cm (4.7 – 43.3 in.)	<b>E75-PPA110P-M12</b>

① For compatible connector cables, see Page 6.

January 2009

Overview — Distance Sensing Models with Analog Outputs



Long-Range, High-Precision Laser Distance Measurement Sensor

- When within the effective range of the sensor, outputs a 0 – 10V signal proportional to the target’s distance from the sensor face
- Class II laser emitter detects objects from 0.3 to 4 m (1 to 13.1 ft.) away
- Two additional PNP outputs can be programmed to switch at predetermined ranges
- Simple three-step teach routine to program range cutoffs
- Unmatched accuracy and resolution at long sensing distances



Short-Range Distance Sensor



- When within the effective range of the sensor, outputs a 0 – 10V signal proportional to the target’s distance from the sensor face
- Visible red LED emitter detects objects from 5 to 10 cm (1.9 to 3.9 in.)
- Two indicator LEDs communicate sensor status: a yellow LED with light intensity proportional to the target’s distance within the sensor’s range, and a red LED that activates when the target is beyond maximum sensing range
- Flat tubular package can be mounted using the body threads or flat against a surface

Distance Sensing Explained

Distance sensors output a 0 – 10V analog signal in proportion to the measurement of the distance between the sensor and target. Optical triangulation, a technology similar to that used in Eaton’s Perfect Prox® or diffuse sensors, is used for short- to mid-range distance sensing applications that do not require a high degree

of accuracy. Time-of-flight technology, a method of measuring the time it takes for the emitted beam to bounce off the target and return to the detector, is used for longer range distance sensing applications. Time-of-flight is highly accurate with precise resolution over long sensing distances.

Model Selection — Distance Sensing Models with Analog Outputs

	Voltage Range	Output Type	Adjustable Sensing Range	Connection	Catalog Number
<b>Long-Range Laser Distance Sensor with Time-of-Flight Technology</b>					
Rectangular (80 x 53 x 31 mm) 	15 – 30V DC	Analog Output (0 – 10V), Dual Teachable PNP Outputs, Light Operate Mode	0.3 – 4.0 m (1.0 – 13.1 ft.)	5-Pin Micro Connector ①	<b>E75-DST400A010-M12</b> ②
<b>Short-Range Distance Sensor</b>					
Flat Tubular (18 mm) 	18 – 30V DC	Analog Output (0 – 10V)	5.0 – 10.0 cm (1.9 – 3.9 in.)	4-Pin Micro Connector ①	<b>E75-DST010A010-M12</b>

① For complete connector cables, see Page 6.

② This sensor is a Class II laser device. Eye irradiation for over 0.25 seconds is dangerous. Refer to the Class II Standard (EN60825-1) for additional safety information.

Overview — Color, Contrast and Luminescence Sensing Models



Color Sensors

- Can be programmed to recognize three different colors independently
- Capable of sensing targets 5 – 45 mm away from the sensor face
- Rectangular plastic package features a four-digit display, two programming buttons and output status LEDs
- Optional serial connection (RS485) allows for remote communications
- Standard M12 8-pin micro connector (mating cable available on **Page 15**)

**Color Sensing Basics**

Color sensors work by using a “chromaticity” detection algorithm. Chromaticity is determined by two characteristics: hue and saturation. Hue is determined by the reflected light’s wavelength, while saturation indicates the pureness percentage (with white representing 0%). Eaton’s color sensor goes one step further and provides an optional “chromaticity plus intensity” algorithm. This mode provides a higher sensitivity to tone variations and is recommended for detection of different colors on the same type of material. It will also better distinguish between gray tones.



Contrast Sensors

- Ideal for detecting different colored or grayscale contrasts, such as registration marks
- Capable of sensing targets out to 10 mm from the sensor face
- Simple three-step setup routine for quick installation or optional “fine setup routine” for more complicated applications
- Complementary outputs can function in either light operate or dark operate modes
- Standard M12 4-pin micro connector (mating cable available on **Page 16**)

The color of a target is determined by the color components of the reflected source light. The target color is identified by analyzing the red (R), green (G) and blue (B) channels of reflected light. For example, yellow can be identified by the following reflections: R=50%, G=50%, B=0%; Orange can be identified by R=75%, G=25%, B=0%; Pink by R=50%, G=0%, B=0%. The RGB combinations are practically limitless. Applications for color sensors are common in many industries, ranging from quality and process control, to automatic material handling for identification, to orientation and selection of objects according to their color.



Luminescence Sensors

- Perfect for the detection of any luminescent target, even on reflective materials such as ceramics, metal or mirrored glass
- Capable of sensing from 8 – 20 mm from the sensor face
- Simple three-step setup routine and optional “fine setup routine” for more complicated applications
- Can function in either light operate or dark operate mode
- Standard M12 4-pin micro connector (mating cable available on **Page 17**)

**Contrast Sensing Basics**

Contrast sensors (also defined as color mark readers, according to their most popular application) go beyond simple presence/absence detection to distinguish two surfaces according to the contrast produced by their difference in reflectivity. For example, a dark reference mark (low reflectivity) can be detected by comparing it against the contrast of the lighter surface (high reflectivity). A white LED light source is used for general purpose contrast sensing, enabling detection of the very slightest of contrast variations — even those that share the same general material and color. Contrast sensors are frequently used in automated packaging applications for registration mark detection to automate the folding, cutting and sorting phases.

January 2009



**Luminescence Sensing Basics**

Luminescence is defined as visible light emission from fluorescent or phosphorescent substances. Luminescence sensors emit ultraviolet light, which is then reflected at a higher wavelength from the target

surface. The UV emission from the sensor is modulated and the visible light received is synchronized, resulting in immunity against external interferences such as reflections caused by shiny objects. Luminescence sensors are used in various

industries to detect labels, fluorescent marks or signs, fluorescent glues on paper, to distinguish cutting and sewing guides, and to check fluorescent paints or lubricants.

**Model Selection — Color, Contrast and Luminescence Sensing Models**



	Voltage Range	Sensing Range	Connector	Output Type	Catalog Number
<b>Color Sensors</b>					
Rectangular (50 x 50 x 25 mm)  	10 – 30V DC	5 – 45 mm (0.19 – 1.77 in.) ①	8-Pin Micro Connector ②	3 N.O. PNP Outputs	<b>E76-CLRMKP-M12</b>
				3 N.O. NPN Outputs	<b>E76-CLRMKN-M12</b>
				3 N.O. NPN Outputs, RS485 Connection ③	<b>E76-CLRMKRS-M12</b>
<b>Contrast Sensors</b>					
Flat Tubular (18 mm)  	10 – 30V DC	10 mm (0.39 in.) ideal	4-Pin Micro Connector ②	Light Operate or Dark Operate, PNP Output	<b>E76-CNT010P-M12</b>
				Light Operate or Dark Operate, NPN Output	<b>E76-CNT010N-M12</b>
<b>Luminescence Sensors</b>					
Flat Tubular (18 mm)  	10 – 30V DC	8 – 20 mm (0.31 – 0.79 in.)	4-Pin Micro Connector ②	Light Operate or Dark Operate, PNP Output	<b>E76-UV020P-M12</b>

① Refer to Detection Diagram on **Page 12**.

② For complete connector cables, see **Page 6**.





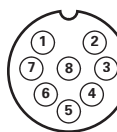

③ Remote sensor communications is possible using the RS485 serial interface. For additional information, see Installation Manual P52078.

**Model Selection — Compatible Connector Cables**

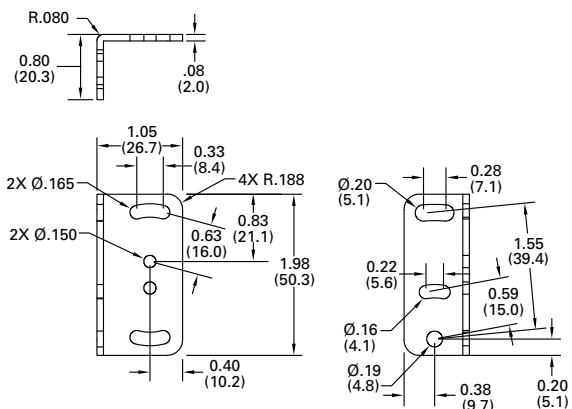
	Voltage Style	Number of Pins	Gauge	Length	Catalog Number			Pins
					PVC	PUR	IRR PUR	
	DC	4-Pin 4-Wire	22 AWG	6.0 ft.	<b>CSDS4A4CY2202</b>	<b>CSDS4A4RY2202</b>	<b>CSDS4A4IO2202</b>	 1-Brown 2-White 3-Blue 4-Black
				16.4 ft.	<b>CSDS4A4CY2205</b>	<b>CSDS4A4RY2205</b>	<b>CSDS4A4IO2205</b>	
				32.8 ft.	<b>CSDS4A4CY2210</b>	<b>CSDS4A4RY2210</b>	<b>CSDS4A4IO2210</b>	
		5-Pin 5-Wire	22 AWG	6.0 ft.	<b>CSDS5A5CY2202</b>	—	—	 1-Brown 2-White 3-Blue 4-Black 5-Green/Yellow
				16.4 ft.	<b>CSDS5A5CY2205</b>	—	—	
				32.8 ft.	<b>CSDS5A5CY2210</b>	—	—	
		8-Pin 8-Wire	24 AWG	4.9 ft. (1.5 m)	<b>CSDS8A8CY2401.5</b>	—	—	 1-White 5-Gray 2-Brown 6-Pink 3-Green 7-Blue 4-Yellow 8-Red
					<b>CSDS8A8CY2405</b>	—	—	
					<b>CSDS8A8CY2410</b>	—	—	

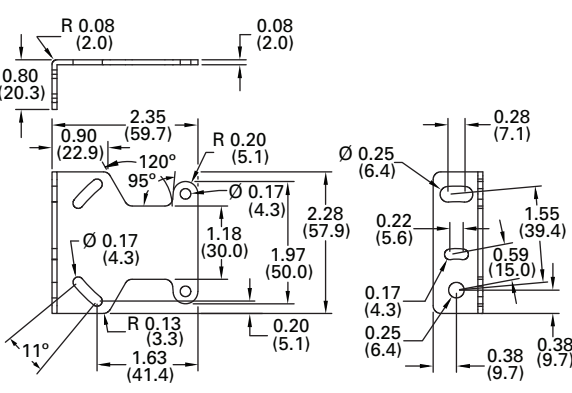
January 2009

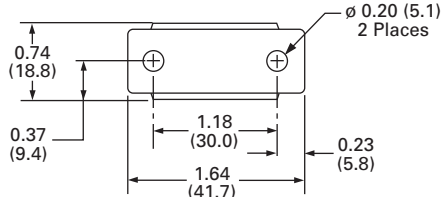
**Model Selection — Accessories**

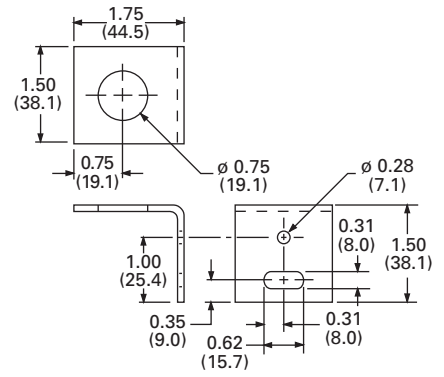
	Description	Sensor Compatibility	Catalog Number	Approximate Dimensions
 <p>Mounting Bracket</p>	<p>L-shaped mounting bracket for IntelliView sensors</p> <p>Mounting hardware included</p>	All models starting with E75-PPA...	<b>E75-MTB1</b>	
 <p>Mounting Bracket</p>	<p>Long L-shaped mounting bracket for IntelliView sensors</p> <p>Mounting hardware included</p>	All models starting with E76-CLR... and E75-PP1MP-M12	<b>E76-MTB1</b>	
 <p>Mounting Bracket Ball Swivel</p>	<p>Allows 360° rotation and 10° vertical tilt</p> <p>Hole spacing is identical to our 50 and 55 Series sensors</p> <p>Ideal for mounting right-angle sensors</p> <p>Made of Noryl®</p>	All 18mm flat tubular sensors	<b>6181AS5200</b>	
 <p>Mounting Bracket L-Shaped</p>	<p>Adjustability: Allows some adjustment in one axis and allows for aiming of the sensor through a short arc</p> <p>Sensor Mounting: Sensor mounts with two jam nuts and washers (included with sensor)</p> <p>Material of Construction: Aluminum with chromate finish</p> <p>Packaging: Two per package</p>	All 18mm flat tubular sensors	<b>6161AS6501</b>	
Additional Mounting Brackets	More mounting brackets compatible with IntelliView sensors	—	See <b>Section 8</b>	

**Wiring Diagrams — IntelliView Series**

Models	Micro Connector Diagram (Face View Male Shown)
Foreground/Background Suppression Models  <i>Models starting with E75-PPA... or E76-PP1...</i>	
Distance Sensing Models (Rectangular Package Only)  <i>E75-DST400A010-M12</i>	
Distance Sensing Models (Tubular Package Only)  <i>E75-DST010A010-M12</i>	
Color Sensing Models  <i>E76-CLRMKN-M12 E76-CLRMKP-M12 E76-CLRMKRS-M12</i>	
Contrast and Luminescence Sensing Models  <i>Models starting with E76-UV... or E76-CN...</i>	

① Direct proportionality (DIR) is activated when the white wire is connected to +V DC. Inverse proportionality (INV) is activated when the white wire is connected to 0V. The white wire must always be connected.  
 ② Available only on E76-CLRMKRS-M12 with RS485 serial connection.

January 2009

Approximate Dimensions — IntelliView Series

Models	Diagram
<p>Foreground/Background Suppression Models</p> <p><i>Models starting with E75-PP1...</i></p>	<p>Technical drawing showing top, side, and detail views of the sensor. Dimensions include: 0.04 (1.1), 1.97 (50.0), 1.65 (42.0), 0.03 (0.8), 0.71 (18.0), 0.19 (4.7), 0.08 (2.0), 18x45°, 0.43 (11.0), 0.24 (6.0), 0.55 (14.0), 0.72 (18.2), 0.61 (15.5), 0.63 (16.0), 0.24 (6.2), 0.42 (10.7), 0.43 (11.0), 0.72 (18.4). Labels include Receiver, Emitter, Distance Adjustment Pot, Position Indicator, Stability LED, and Output LED. Connector is M12 with diameter ø0.59 (ø15.0).</p>
<p>Foreground/Background Suppression Models</p> <p><i>Models starting with E75-PPA...</i></p>	<p>Technical drawing showing top, side, and detail views of the sensor. Dimensions include: 0.02 (0.5), 1.97 (50.0), 1.57 (40.0), 0.02 (0.5), 0.02 (0.5), 1.57 (40.0), 0.02 (0.5), 0.28 (7.0), 0.47 (12.0), 0.71 (18.0), 1.06 (27.0), n°2 ø4.6, M12, ø0.59 (ø15.0). Labels include Output LED, Stability LED (E75-PPA025/050/110), and Adjustment Screw (E75-PPA025/050/110).</p>
<p>Distance Sensing Models (Rectangular Package Only)</p> <p><i>E75-DST400A010-M12</i></p>	<p>Technical drawing showing top, side, and detail views of the sensor. Dimensions include: 1.22 (31.0), 1.50 (38.0), 1.10 (28.0), 2.09 (53.0), 1.61 (40.8), 1.61 (41.0), 0.62 (15.7), 1.85 (47.0), 0.69 (17.5), 0.98 (25.0), 1.22 (31.0), 0.96 (24.5), 0.55 (14.0), 0.59 (15.0), 3.15 (80.0), 0.83 (21.0), 1.10 (28.0). Labels include Button, Power On / Alarm LED, Output LED, and M5 depth 6 mm max. (4 mounting holes).</p>

① Connector can rotate 90- or 180-degrees to accept different sensor mounting orientations.

Approximate Dimensions — IntelliView Series (Continued)

Models	Diagram
<p>Distance Sensing Models (Tubular Package Only)</p> <p><i>E75-DST010A010-M12</i></p>	
<p>Color Sensing Models</p> <p><i>E76-CLRMKN-M12</i> <i>E76-CLRMKP-M12</i> <i>E76-CLRMKRS-M12</i></p>	
<p>Contrast and Luminescence Sensing Models</p> <p><i>Models starting with E76-UV... or E76-CN...</i></p>	

① Connector can rotate 90- or 180-degrees to accept different sensor mounting orientations.

January 2009

**Detection Diagrams — IntelliView Series**

Models	Diagram
Foreground/Background Suppression Models  <i>Models starting with E75-PPA... or E76-PP1...</i>	Black /White Difference — E75-PPA010P-M12 ① 
	Black /White Difference — E75-PPA025P-M12 ① 
	Black /White Difference — E75-PPA050P-M12 ① 
	E75-PPA110P-M12 
Distance Sensing Models (Rectangular Package Only)  <i>E75-DST400A010-M12</i>	Analog Output Diagram 
	Digital Output Diagram 
	Black/White Difference 
Distance Sensing Models (Tubular Package Only)  <i>E75-DST010A010-M12</i>	Analog Output Diagram (Direct Proportionality – Default) 
	Analog Output Diagram (Inverted Proportionality) 

① These diagrams depict the width of the sensing beam over distance. These diagrams also show the sensing difference between white and gray targets. Because gray is less reflective than white, gray targets will typically need to come closer to the beam centerpoint to be detected.

Detection Diagrams — IntelliView Series (Continued)

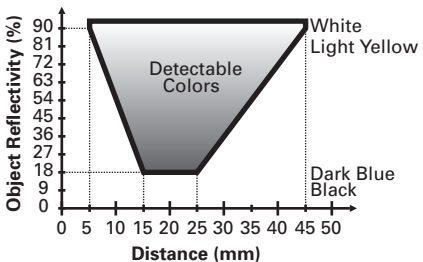
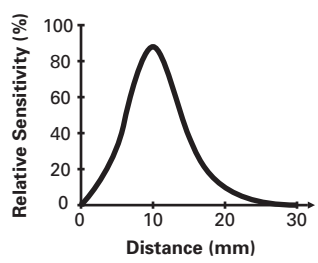
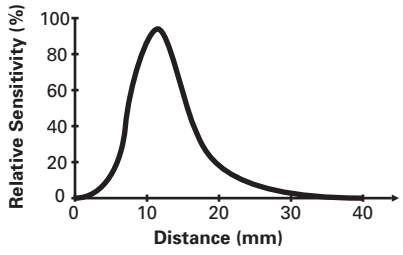
Models	Diagram
<p>Color Sensing Models</p> <p><i>E76-CLRMKN-M12</i> <i>E76-CLRMKP-M12</i> <i>E76-CLRMKRS-M12</i></p>	<p style="text-align: center;">Color Detection Diagram</p> 
<p>Luminescence Sensing Models</p> <p><i>Models starting with E76-CN...</i></p>	<p style="text-align: center;">Contrast Detection Diagram</p> 
<p>Luminescence Sensing Models</p> <p><i>Models starting with E76-UV...</i></p>	<p style="text-align: center;">Luminescence Detection Diagram</p> 

January 2009

**Specifications — Foreground/Background Suppression Models**

	Foreground/Background Suppression Models
Input Voltage	10 – 30V DC
Ripple	2 Vpp max.
Outputs	PNP, N.O. or N.C.; 30V DC max.
Output Current	100 mA max. (short-circuit protected)
Output Saturation Voltage	< 2V max.
Response Time	1 ms
Switching Frequency	500 Hz
Indicator LEDs	For E75-PPA: Output LED (red), Stability LED (green) For E75-PP1: Output LED (yellow), Stability LED (green)
Gain Adjustment	For E75-PPA: Adjustment screw (except for E75-PPA010P) For E75-PP1: Six-turn adjustment pot with numerical indicator
Operating Temperature	-25 to +55°C (-13 to +131°F)
Storage Temperature	-25 to +70°C (-13 to +158°F)
Electrical Protection	Class 2
Sensing Distance	Varies by model, see model selection table on <b>Page 5</b>
Beam Type	All Models Except E75-PPA010P-M12: Infrared LED 880nm E75-PPA010P-M12: Red LED
Vibration	Amplitude: 0.5 mm Frequency: 10 – 55 Hz for every axis (EN60068-2-6)
Shock Resistance	Half sine, 30 g <sub>r</sub> , 11 ms, 3 axes
Housing Material	ABS
Lenses	PMMA
Enclosure Ratings	For E75-PPA...: IP65 For E75-PP1...: IP67
Connections	M12 4-pin connector
Weight	40g max.

**Specifications — Distance Sensing Models**

	Distance Sensing Models	
	For E75-DST4... (Long-Range Distance Sensor)	For E75-DST0... (Short-Range Distance Sensors)
Input Voltage	16 – 28V DC	18 – 30V DC
Burden Current	2 Vpp max.	
Current Consumption (Output Current Excluded)	120 mA max.	30 mA max.
Outputs	Analog, 0 – 10V 2 PNP outputs 30V DC max.	Analog, 0 – 10V
Output Switching Mode	Light operate (output on when target present)	Output can be inverted via button
Output Current	100 mA max. (short-circuit protected)	—
Output Saturation Voltage	< 2V max.	—
Response Time	12 ms	7.3 ms
Switching Frequency	42 Hz	68 Hz
Indicator LEDs	2 Output LEDs (yellow) Power/Alarm LED (green)	Output LED (yellow) Field LED (red)
Distance Adjustment	Dual buttons	—
Warm-Up	15 min.	—
Operating Temperature	0 to +50°C (+32 to +122°F)	-10 to +55°C (+14 to +131°F)
Storage Temperature	-20 to +70°C (-4 to +158°F)	-20 to +70°C (-4 to +158°F)
Measurement Range	0.3 – 4.0 m (1.0 – 13.1 ft.)	5.0 – 10.0 cm (1.9 – 3.9 in.)
Linearity	< 1% (24V DC, 25°C, with 90% white target)	—
Repeatability	± 4 mm	—
Hysteresis	20 mm	—
Temperature Drift	< 1 mm per °C	—
Beam Type	Red Laser (665 nm), Class 2 EN 60825-1 (1994) + A1 (2002) + A2 (2001)	Red LED (630 nm)
Vibration	Amplitude: 0.5 mm, Frequency: 10 – 55 Hz for every axis (EN60068-2-6)	
Shock Resistance	Half sine, 30 g <sub>r</sub> , 11 ms, 3 axes	
Material of Construction	ABS	PBT
Lenses	PMMA	
Enclosure Ratings	IP67	
Connections	M12 5-pin micro connector	M12 4-pin micro connector
Weight	92g max.	25g max.
Approvals	UL, C-UL, CE	

January 2009

**Specifications — Color Sensing Models**

	Color Sensing Models
Input Voltage	10 – 30V DC
Burden Current	2V max.
Current Consumption (Output Current Excluded)	60 mA max.
Outputs	3 PNP outputs 30V DC max. (short-circuit protected)
Output Current	100 mA max.
Output Saturation Voltage	< 2V
Response Time	650 µs
Switching Frequency	770 Hz
Indicator LEDs	4-Digit Display (green), Output LED (yellow), 3 Status LEDs (green)
Sensing Adjustment	SET, SEL buttons
Operating Temperature	-10 to +55°C (+14 to +131°F)
Storage Temperature	-20 to +70°C (-4 to +158°F)
Protection	Class 2
Sensing Distance	20 mm (0.79 in.)
Beam Spot Dimension	Ø 4 mm
Beam Type	White Light LED (400 – 700 nm)
Vibration	Amplitude: 0.5 mm, Frequency: 10 – 55 Hz for every axis (EN60068-2-6)
Shock Resistance	Half sine, 30 g <sub>n</sub> , 11 ms, 3 axes
Material of Construction	ABS Thermoplastic
Lens Material	Glass window and lens
Mechanical Protection	IP67
Connections	M12 8-pin micro connector
Approvals	UL, C-UL, CE

**Specifications — Contrast Sensing Models**

	Contrast Sensing Models
Input Voltage	10 – 30V DC
Burden Current	2V max.
Current Consumption (Output Current Excluded)	25 mA max.
Outputs	PNP or NPN by model, NO and NC, 30 Vcc max. (short-circuit protected)
Output Current	100 mA max.
Output Saturation Voltage	< 2V
Response Time	185 µs
Switching Frequency	2.7 kHz
Indicator LEDs	Output LED (yellow) Ready/Error LED (green/red)
Data Retention	EEPROM non-volatile memory
Operating Mode	Light operate on NO output Dark operate on NC output
Operating Temperature	-10 to +55°C (+14 to +131°F)
Storage Temperature	-20 to +70°C (-4 to +158°F)
Operating Distance	10 mm ± 2 mm
Beam Type	White LED (400 – 700 nm)
Vibration	Amplitude: 0.5 mm, Frequency: 10 – 55 Hz for every axis (EN60068-2-6)
Shock Resistance	Half sine, 30 g <sub>r</sub> , 11 ms, 3 axes
Material of Construction	PBT
Lenses	PMMA Plastic
Enclosure Ratings	IP67
Connections	M12 4-pin micro connector cable
Weight	25g max.
Approvals	UL, C-UL, CE

January 2009

**Specifications — Luminescence Sensing Models**

	Luminescence Sensing Models
Input Voltage	10 – 30V DC
Burden Current	2V max.
Current Consumption (Output Current Excluded)	25 mA max.
Outputs	PNP or NPN by model, N.O. and N.C., 30 Vcc max. (short-circuit protected)
Output Current	100 mA max.
Output Saturation Voltage	< 2V
Response Time	1.1 ms
Switching Frequency	445 Hz
Indicator LEDs	Output LED (yellow) Relay/Error LED (green/red)
Data Retention	EEPROM non-volatile memory
Operating Mode	Light operate on N.O. output Dark operate on N.C. output
Operating Temperature	-10 to +55°C (+14 to +131°F)
Storage Temperature	-20 to +70°C (-4 to +158°F)
Sensing Distance	8 – 20 mm (best signal at 10 mm)
Beam Type	White LED (400 – 700 nm)
Vibration	Amplitude: 0.5 mm, Frequency: 10 – 55 Hz for every axis (EN60068-2-6)
Shock Resistance	Half sine, 30 g <sub>r</sub> , 11 ms, 3 axes
Material of Construction	PBT
Lens Material	PMMA Plastic
Enclosure Ratings	IP67
Connections	M12 4-pin micro connector cable
Weight	25g max.
Approvals	UL, C-UL, CE

