

### EPRM Series Current Sensor CurrentWatch Current Sensors

#### Contents

Overview .....	1
Model Selection, Switches .....	2
Wiring Diagram .....	2
Specifications .....	3
Dimensions .....	3

The CurrentWatch EPRM Series from Eaton's electrical business is a family of DIN-rail compatible, split-core current sensors. Product features include a large aperture, switch-selectable inputs and outputs and isolation between primary and secondary circuits. A patented technology eliminates the use of a magnetic core and protects the sensor against saturation and damage, which can occur from continuous exposure to high currents. Models available up to 400A and with 0 – 5/0 – 10V DC or 4 – 20 mA outputs as standard.

For typical applications of the Current-Watch™ EPRM Series, see listing to the right.

#### Approvals

- UL Listed (Pending)
- C-UL Listed (Pending)



**Unless otherwise noted, the products contained in this document are not designed or intended for use in human safety applications.**

### AC Current Sensors with Up to 400A Input Range and Analog Outputs

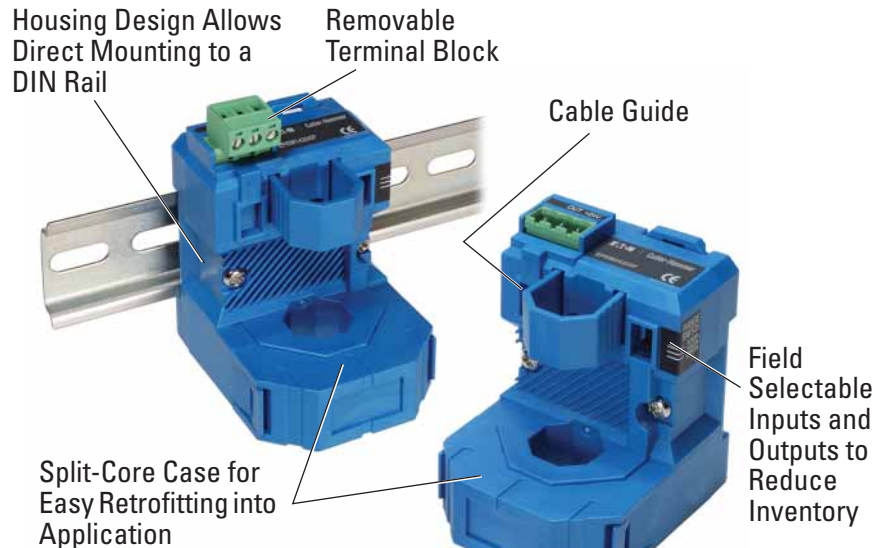

#### Product Features

- **True RMS Output Models Available** — True RMS technology is accurate on distorted waveforms like VFD or SCR outputs
- **Switch-Selectable Input and Output Ranges** — Field selectable input accommodates multiple AC current ranges, while voltage output models offer choice of 0 – 5V DC or 0 – 10V DC analog outputs
- **Application Versatility** — Supports input ranges of up to 400A and standard 50/60 Hz or distorted (VFD, SCR) loads
- **Agency Approvals and Patented Technology** — CE Approved and UL 508 Pending with a patented technology that eliminates problems inherent with magnetic technology such as core saturation

#### Typical Applications

- **Motor Control Centers** — Motor status monitoring for pumps and conveyors, and can be used with panel meters for inexpensive indication of motor current status
- **Automation and Data Logging** — Loop-powered units help conserve data logger batteries and 0 – 10V/4 – 20 mA outputs are ideal for remote monitoring and alarm functions and are compatible with most automation systems and PLCs
- **VFD Controlled Loads** — Monitoring VFD output indicates how the motor and attached load are operating

#### Why "True RMS"?

The current waveform of a typical linear load is a pure sine wave. In VFD and SCR applications, however, output waveforms are rough approximations of a sine wave. There are numerous spikes and dips in each cycle. Certain models in the CurrentWatch™ EPRM Series use a mathematical algorithm called "True RMS" which integrates the actual waveform over time. The output is the amperage component of the true power (heating value) of the AC current waveform. True RMS is the only way to accurately measure distorted AC waveforms. **Select the EPRM Series True RMS models for nonlinear loads in "noisy" power environments.**

For Customer Service in the U.S. call **1-877-ETN CARE (386-2273)**,  
in Canada call **1-800-268-3578**.  
For Application Assistance in the U.S. and Canada  
call **1-800-426-9184**.

October 2007

**Model Selection — CurrentWatch EPRM Series**

	Power Supply	Output Signal	Current Selectable Range	Catalog Number
<b>AC Current Sensors</b>				
Split-Core Housings 	24V DC ± 5% Auxiliary Power	0 – 5 or 0 – 10V DC	10, 25 or 50A	EPRM0510ASP
			50, 75 or 100A	EPRM1510ASP
			100, 150 or 200A	EPRM2510ASP
			200, 300 or 400A	EPRM3510ASP
	24V DC ± 5% Loop-Powered	4 – 20 mA	10, 25 or 50A	EPRM0420LSP
			50, 75 or 100A	EPRM1420LSP
			100, 150 or 200A	EPRM2420LSP
			200, 300 or 400A	EPRM3420LSP

**True RMS Sensors**

Split-Core Housings 	24V DC ± 5% Auxiliary Power	0 – 5 or 0 – 10V DC	10, 25 or 50A	EPRMR0510ASP
			50, 75 or 100A	EPRMR1510ASP
			100, 150 or 200A	EPRMR2510ASP
			200, 300 or 400A	EPRMR3510ASP
	24V DC ± 5% Loop-Powered	4 – 20 mA	10, 25 or 50A	EPRMR0420LSP
			50, 75 or 100A	EPRMR1420LSP
			100, 150 or 200A	EPRMR2420LSP
			200, 300 or 400A	EPRMR3420LSP

■ Stocked product, typical order quantities guaranteed in stock.

**Wiring Diagram — CurrentWatch EPRM Series**

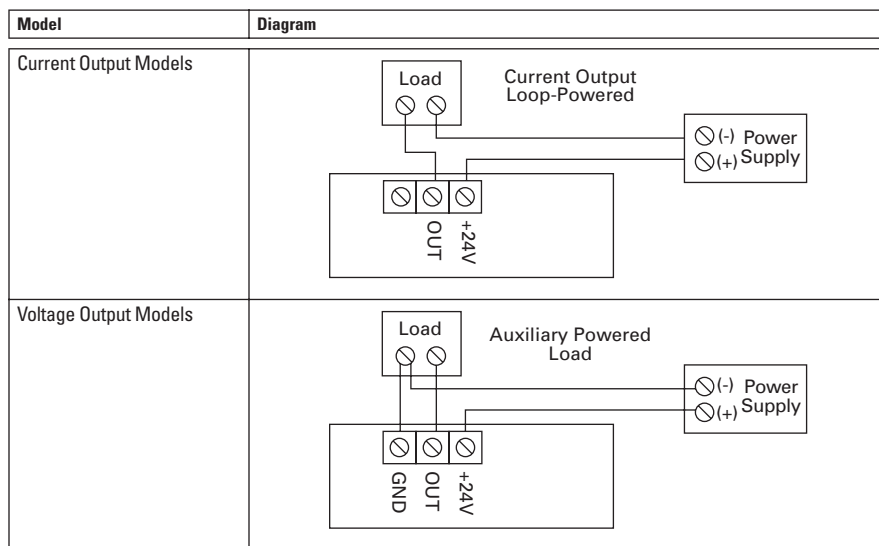

**Specifications — CurrentWatch EPRM Series**

Description	Voltage Output Models (0 – 5 or 0 – 10V)	Current Output Models (4 – 20 mA)
Power Supply	24V DC $\pm$ 5%	Loop-Powered
Output Signal	0 – 5 or 0 – 10V DC	4 – 20 mA
Electrical Offset	< 0.5%	4 mA
Accuracy	1.0% FS	
Loading	Voltage Output Models: 10 Kohm Recommended	
Response Time	EPRM: <500 mS EPRMR: <1,000 mS	
Frequency Range	20 – 6,000 Hz	
Linearity	0.5%	
Input Ranges	0 – 400A Switch Selectable	
Sensing Aperture	0.74 in. (19 mm) sq.	
Housing	UL94 V0 Flammability Rated	
Environmental	Operating Temperature: -4 to 122°F (-20 to 50°C) Humidity: 0 – 95% RH, Non-condensing	
Approvals	UL 508 Industrial Control Equipment (Pending, USA and Canada), CE Certified	

**Approximate Dimensions in Inches (mm) — CurrentWatch EPRM Series**
