

August 2007

**80 Series
Photoelectric Sensors****Contents**

Overview	1
Model Selection, Sensor Heads	2
Model Selection, Control Units	3
Model Selection, Logic Modules	4
Model Selection, Accessories	4
Wiring Diagrams	5
Specifications	5
Dimensions	6

The Cutler-Hammer® 80 Series by Eaton's electrical business combines the advantages of self-contained packaging with the flexibility of interchangeable sensor heads. 80 Series sensors provide high optical performance and are excellent for dirty, dusty, wet, steamy or smoky application environments.

The 80 Series offers a choice of nine sensor heads, seven control units, and three logic modules. Output functions are provided by the control units. All sensor heads, control units, and logic modules are interchangeable. Sensor heads are available in reflex or diffuse reflective models in visible-beam and infrared versions. A fiber optic model is also available. Sensor heads plug directly on top of the control units, providing an integrated package with NEMA 1, 3, 4, 12 and 13 ratings.



Unless otherwise noted, the products contained in this document are not designed or intended for use in human safety applications.

Extremely Long Sensing Ranges and the Flexibility of Interchangeable Components

High-Powered Optics
Provide Long Sensing
Ranges

Modular Construction
with Separate Heads
and Control Units



Plug-In
Logic Modules
Yield
Additional
Functionality

1/2" NPT
Conduit Entrance
on Bottom of Unit

Product Features

- High optical performance for long sensing ranges
- Interchangeable design so you can optimize the sensor to meet your needs
- Plug-in logic modules provide time delay, one-shot or retriggerable one-shot functions
- AC high current control units are rated for 1A output current
- AC low leakage control units switch AC or DC loads and are ideal for use with programmable controllers
- DC control units provide complementary NPN outputs for light and dark activation
- A beam status alignment indicator on all units glows brightly when the unit is properly aligned
- Sensitivity adjustment allows you to fine tune performance for the application
- Control units feature a light/dark selection switch for easy selection of output device normally open or normally closed operation
- Easy terminal wiring with built-in 1/2-inch NPT conduit entrance for convenience and protection

For Customer Service in the U.S. call **1-877-ETN CARE (386-2273)**,
in Canada call **1-800-268-3578**.
For Application Assistance in the U.S. and Canada
call **1-800-426-9184**.

Model Selection — Sensor Heads

	Sensing Mode	Sensing Beam	Sensing Range	Optimum Range	Field of View	Response Time (Maximum)		Catalog Number
						Dark-to-Light	Light-to-Dark	
 <p>1480B-6501 ■</p> <p>1383B-6501 ■</p> <p>1580B-6501 ■</p>	Reflex ^②	Infrared	50 feet (15m) min.	—	4 inch (101.6 mm) diameter at 10 feet (3m)	3 mS	5 mS	1480B-6501
		Visible Red	32 feet (10m) min.	—		3 mS	5 mS	1480R-6501
	Diffuse Reflective ^①	Infrared	7 inches (177.8 mm) ^⑤	0.2 – 4.5 inches (5.1 – 114.3 mm)	0.7 inch (17.8 mm) diameter at 4 inches (101.6 mm)	3 mS	5 mS	1380B-6501
		Infrared	18 inches (457.2 mm) ^⑤	0.5 – 12 inches (12.7 – 304.8 mm)	0.7 inch (17.8 mm) diameter at 8 inches (203.2 mm)	3 mS	5 mS	1381B-6501
		Infrared	8 feet (2.44m) ^⑤	—	8 inch (203.2 mm) diameter at 100 inches (2540 mm)	3 mS	5 mS	1382B-6501
		Infrared	12 feet (3.66m) ^⑤	1 – 7 feet (0.3 – 2m)	7 inch (177.8 mm) diameter at 5 feet (1.5m)	3 mS	5 mS	1384B-6501
		Focused Infrared	6 inches (152.4 mm) ^⑤	3 – 5 inches (76.2 – 127 mm)	0.2 inch (5.1 mm) diameter at 3 – 5 inches (76.2 – 127 mm)	3 mS	5 mS	1383B-6501
		Focused Visible Red	5 inches (127 mm) ^⑤	4 inches (101.6 mm)	0.1 inch (2.5 mm) diameter at 3.5 – 4 inches (88.9 – 101.6 mm)	3 mS	5 mS	1383R-6501
	Fiber Optic (See PG.05E.15.T.E for E51KF Style Glass Fiber Optic Cables)	Infrared	8 inches (0.20m) ^③ 2 inches (0.05m) ^④	—	—	3 mS	5 mS	1580B-6501

^① Effective beam diameter is 1.25 x 0.8 inches (31.75 x 20.32 mm). Sources use any control unit — output is not connected.

^② Ranges based on a 3 inch (76.2 mm) retroreflector.

^③ Thru-beam range with 3-foot long, 0.125 inch (3.17 mm) diameter fiber.

^④ Diffuse reflective range with 3-foot long, 0.125 inch (3.17 mm) diameter fiber, based on 90% reflectance white card.

^⑤ Ranges based on a 90% reflectance white card.

■ Fast turn product with typical one business day lead-time to shipment.

Excess Gain

Reflex

Ranges based on a 3 inch (76.2 mm) retroreflector.

- 1480R
- 1480B

Fiber Optic

- Diffuse reflective range with 3-foot long, 0.125 inch (3.17 mm) diameter fiber, based on 90% reflectance white card.
- Thru-beam range with 3-foot long, 0.125 inch (3.17 mm) diameter fiber.

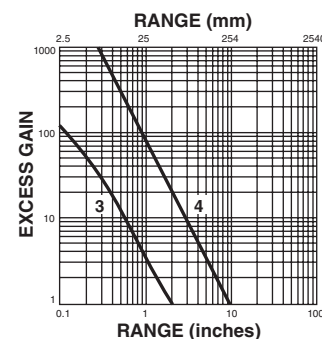
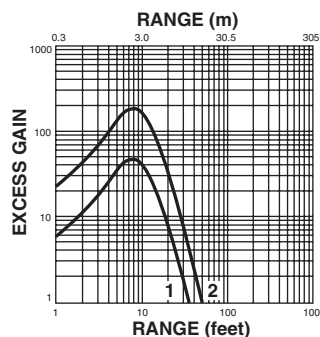

August 2007

Excess Gain

Diffuse Reflective
Ranges based on a 90% reflectance white card.

- 5. 1380B
- 6. 1381B
- 7. 1382B
- 8. 1384B
- 9. 1383R
- 10. 1383B

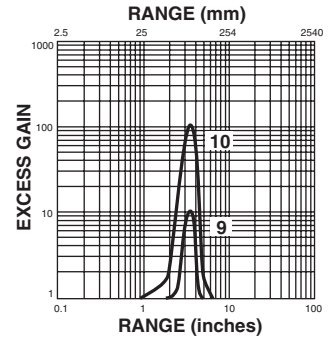
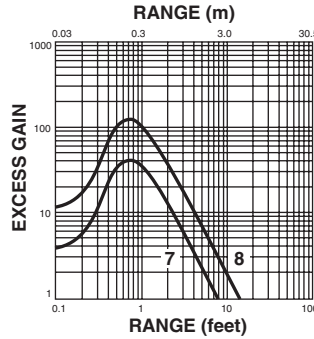
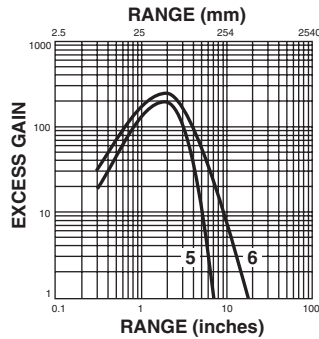

Model Selection — Control Units (Connection is by Terminal Wiring)

	Type	Input		Output					Catalog Number	
		Voltage	VA	Type/Response Time	ON-State	Maximum Load Current	OFF-State Leakage	Surge Current		
	High Current	97 – 130V AC, 50/60 Hz	Less than 4.5 VA	TRIAC — Operates as a SPST solid-state relay for switching non-capacitive AC loads up to 1A; response time is 8 mS maximum	< 1.5V from 100 mA to 1A	1A at 75°F — derated linearly to 0.5A at 130°F	< 2 mA at 120V AC	30A max. for 1/2 cycle; 10A for 1/2 second	8880C-6501	
		204 – 255V AC, 50/60 Hz	Less than 4.5 VA				< 4 mA at 230V AC			8881C-6501
		22 – 26V AC, 50/60 Hz	Less than 4.5 VA				< 0.35 mA at 24V AC			
	Low Leakage ①	22 – 26V AC, 50/60 Hz	Less than 4.5 VA	VMOS — Operates as a SPST solid-state switch for loads up to 50 mA — switches up to 188V DC or 132V AC; response time is 2 mS maximum	< 2.5V from 5 mA to 50A	50 mA _{RMS}	< 20 μA at 24V _{RMS}	250 mA for 1 cycle; 100 mA for 1 second	8884C-6502	
		97 – 130V AC, 50/60 Hz	Less than 4.5 VA				< 50 μA at 110V _{RMS}		8880C-6502	
		204 – 255V AC, 50/60 Hz	Less than 4.5 VA				TRIAC — Operates as a SPST solid-state switch for loads up to 50 mA — switches up to 256V AC; response time is 8 mS maximum		< 3V from 4 mA to 50A	< 200 μA at 240V _{RMS}
DC	10 – 30V DC ②		Complementary NPN; response time is instantaneous	< 0.5V at max. current rating 200 mA	200 mA	Output shuts off up to 30V DC at less than 20 μA leakage	—	8882B-6501		

① Extremely low leakage in OFF-state makes this unit ideal for use as an input to a programmable controller.



② Unregulated, derated to 10 – 20V DC above 115°F, less than 90 mA.

Fast turn product with typical one business day lead-time to shipment.

Model Selection — Logic Modules

	Description	Operation	Selectable Ranges	Catalog Number
	Time Delay Delays response of the sensor until the beam has been broken for a set period of time (ON-delay), or completed for a set period of time (OFF-delay). Time delays are disabled for 20 mS on power-up	Provides ON and OFF time delays ranging from 0.01 to 20 seconds. Independently adjustable. Once delay range is switch selected, the exact delay is adjusted via separate potentiometers for ON-and OFF-delay	0.01 to 0.2 seconds 0.1 to 2.0 seconds 1.0 to 20.0 seconds	8280A-6501
	One-Shot Triggered by sensing the leading or trailing edges of objects, these modules produce a pulse of preset time when triggered	Switch-selectable to start one-shot pulse from light-to-dark or dark-to-light transition. Switch-selected pulse width ranges — once range is selected, the exact pulse width is adjusted via a potentiometer	0.01 to 0.4 seconds 0.04 to 5.0 seconds 0.2 to 25.0 seconds	8281A-6501
	Retriggerable One-Shot/Motion Detector Like the one-shot module, this module produces a pulse of a preset width when triggered. The difference is the width of the pulse can be lengthened by successive triggering. As long as the module is triggered, the output stays high	The one-shot function is triggered by light-to-dark or dark-to-light transitions, as selected by the user. Switch-selected retrigger interval — once a range is selected, the exact interval is adjusted via a potentiometer	0.01 to 0.2 seconds 0.1 to 2.5 seconds	8282A-6501

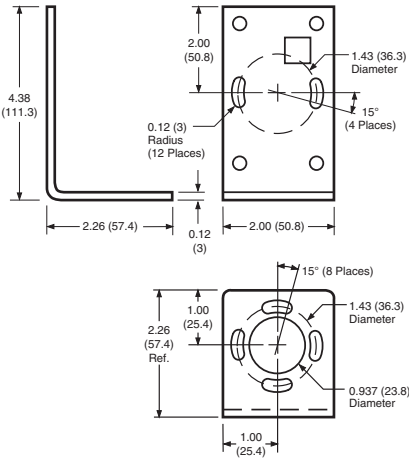
Model Selection — Accessories

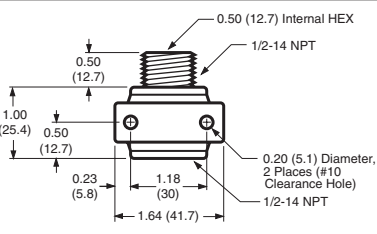
Description		Catalog Number	Approximate Dimensions in Inches (mm)
Swivel Mounting Bracket 	Zinc plated steel	6180A-6501	
Ball Swivel Mounting Bracket 	Allows 360° rotation and 10° vertical tilt for easy installation and alignment of 80 Series sensors	6181A-6501	
Retroreflectors	Retroreflectors and retroreflective tape	See PG.05E.17.T.E	

■ Stocked product, typical order quantities guaranteed in stock.

August 2007

Wiring Diagrams — Control Units

Triac Output:
8880C-6501,
8881C-6501,
8881C-6502 and
8884C-6501

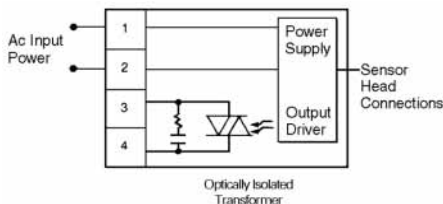

VMOS Output:
8880C-6502 and
8884C-6502

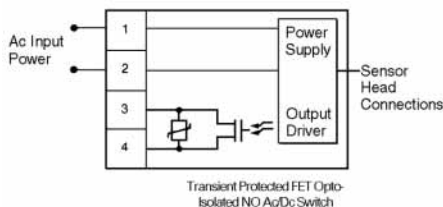

DC: 8882B-6501

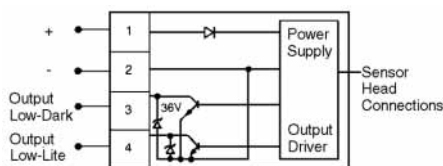

Specifications — Assembled Sensors

Description	Specification
Response Time: High Current Low Leakage Except Cat. No. 8881C-6502 Cat. No. 8881C-6502 DC	8 mS maximum 2 mS maximum 8 mS maximum Instantaneous
Sensitivity Adjustment	20:1 ratio nominal
Operating Temperature	-4° to 131°F (-20° to 55°C)
Humidity	95% relative humidity, non-condensing
Material of Construction	Housing: Noryl® ①; Lens: Clear polycarbonate ①
Sunlight Immunity	10,000 foot-candles
Vibration	5g or 0.06 inch displacement, whichever is less, over 20 Hz to 2 kHz
Shock	15g minimum for 1 mS
Enclosure Ratings	NEMA 1, 3, 4, 12 and 13 ②
Power On Condition	No False Pulse

① Avoid exposing to chlorinated, halogenated or aromatic hydrocarbons.

② NOTE: Our products conform to NEMA tests as indicated, however, some severe washdown applications can exceed these NEMA test specifications. If you have questions about a specific application, contact Eaton's Cutler-Hammer Sensor Applications Department at 1-800-426-9184.

Approximate Dimensions in Inches (mm)

All Control Units with: 1380B, 1381B, 1382B, 1384B, 1480B, 1480R, 1580B Sensor Heads

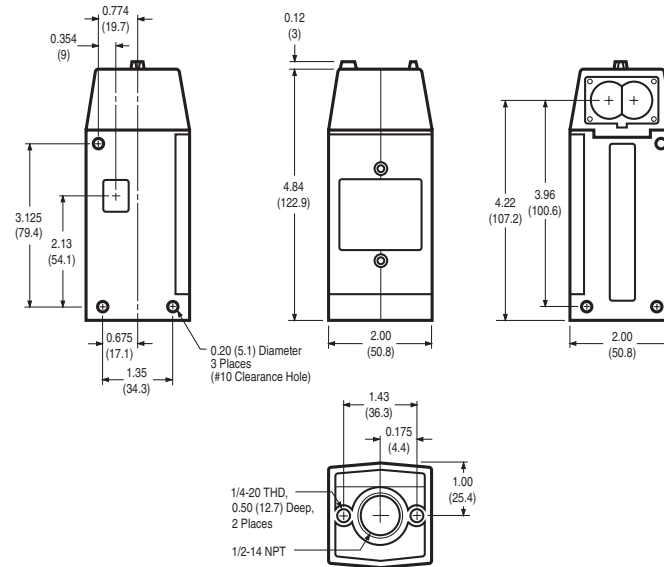

All Control Units with: 1383B and 1383R Sensor Heads

