

11 Series Photoelectric Sensors

Contents

Overview.....	1
Model Selection, Sensors.....	2
Model Selection, Output Devices.....	2
Model Selection, Logic Module.....	3
Model Selection, Accessories.....	3
Wiring Diagram.....	3
Specifications.....	4
Dimensions.....	4

The Cutler-Hammer® 11 Series from Eaton's electrical business is a highly configurable photoelectric sensor. The sensor operates in the reflex sensing mode with a choice of visible or infrared source light. Select one of four different output devices to match your control needs. An optional time delay logic module is also available.



Unless otherwise noted, the products contained in this document are not designed or intended for use in human safety applications.

Self-Contained, with Multiple Output Options Including High Current DPDT Relay

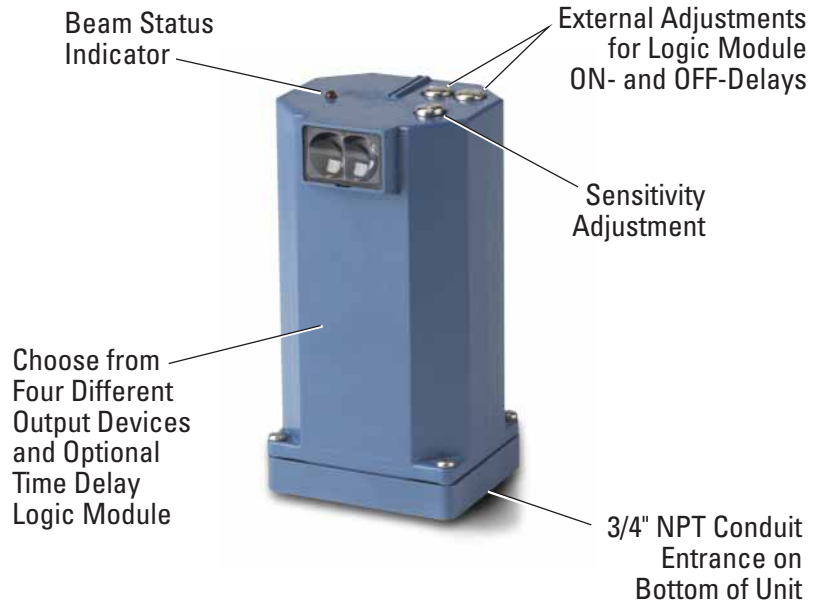

Product Features

- Quick disconnect base for easy installation and maintenance
- Beam status indicator glows brightly when the sensor is properly aligned
- Four different output devices to tailor the sensor to your control system
- Optional logic module provides independent ON-delay and OFF-delay functions
- Output devices and logic modules mount inside the sealed housing
- Directly interchangeable with Photoswitch® 4000 Series, P&F/Microswitch® FE MLS 8 units, and other similar models
- Power-up suppression and switch selection of light/dark operation

NOTE: Photoswitch and Microswitch are registered trademarks of Photoswitch Corp. and Microswitch Inc., respectively.

For Customer Service in the U.S. call **1-877-ETN CARE (386-2273)**,
in Canada call **1-800-268-3578**.
For Application Assistance in the U.S. and Canada
call **1-800-426-9184**.

August 2007

Model Selection — Reflex Sensors

Type	Sensing Range ^①	Optimum Range	Sensing Beam	Input Power		Catalog Number
				Voltage	Volt Amperes	
	20 feet (6.1m)	2.5 – 10 feet (0.8 – 3.0m)	Visible Red	115 – 125V AC, 50/60 Hz	6 VA max.	1411R-6501
				230V AC, 50/60 Hz	6 VA max.	1411R-6502
	30 feet (9.1m)	1 – 15 feet (0.3 – 4.6m)	Infrared	115 – 125V AC, 50/60 Hz	6 VA max.	1411D-6501
				230V AC, 50/60 Hz	6 VA max.	1411D-6502

① Ranges based on a 3 inch reflector (not included).

■ Fast turn product with typical one business day lead-time to shipment.

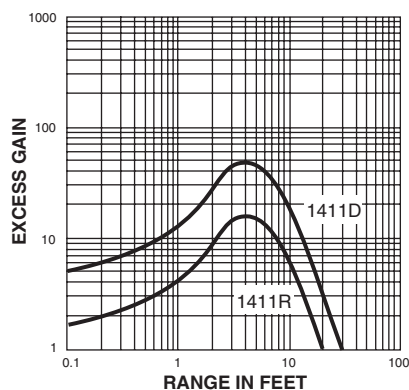
Excess Gain^②

② Based on a 3 inch reflector (not included).

Model Selection — Output Devices (One required for sensor operation)

	Description	Input		Output				Catalog Number	
		Operating Voltage	Current	Type	ON-State Current	OFF-State Leakage	ON-State V Drop		One Cycle Surge A
	DPDT Relay Plug-in industrial control relay. Polycarbonate housing.	12V DC nominal. Power supplied by control unit	75 mA at 75°F 12V DC	DPDT	Contact Ratings: Resistive Load: 10A, 1/4 hp maximum at 110/220V AC, 10A maximum at 28V DC Inductive Load: 7A maximum at 110/220V AC, 7A maximum at 28V DC Contact Life: 500,000 operations at rated load				8530A-6501
	Isolated Triac Optically isolated, industrial solid-state relay for switching non-capacitive AC loads. Response is 100,000 operations/hour. Polycarbonate housing.	3 – 20V DC. Power supplied by control unit	—	SPST Normally open triac	2 A _{RMS} at 25°C, 1 A _{RMS} at 65°C	5 mA at 100V AC, 9 mA at 200V	1.7 V _{RMS} or less	60A peak	8572A-6501
	Triac, PC Compatible Optically isolated, industrial solid-state relay for switching non-capacitive AC loads. Response is 100,000 operations/hour. Polycarbonate housing.	8 – 20V DC. Power supplied by control unit	9.5 – 20 mA	SPST Normally open triac	5 – 500 mA _{RMS} at 70°C	1.5 mA at 120V AC	1.7V maximum	6A peak	8573A-6501
	Isolated NPN Transistor Optically isolated, NPN SPST transistor switch. Plastic housing.	12V DC nominal	20 mA typical	Optically isolated NPN transistor switch	20 mA at V _{SAT} less than 0.2V, 500 mA at V _{SAT} less than 1V ^③	10 μA maximum at 30V DC ^④	—	—	8586A-6501

③ For 3-wire connection. For 2-wire connection, 100 mA at V_{SAT} less than 1.2V.

④ For 3-wire connection. For 2-wire connection, 0.1 μA maximum at 30V DC.

■ Stocked product, typical order quantities guaranteed in stock.

Model Selection — Logic Module (Optional, not required for sensor operation)

	Description	Operation	Timing Range	Catalog Number
	Time Delay Delays response of the sensor until the beam has been broken for a set period of time (ON-delay), or until the beam has been completed for a set period of time (OFF-delay)	Independent adjustments provided for ON-delay and OFF-delay timing. Time delays are disabled for 20 mS upon power-up	0.05 to 5 seconds in one range	8211B-6501

Model Selection — Accessories

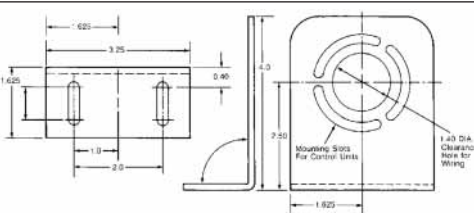
Description	Catalog Number	Approximate Dimensions in Inches
Swivel Mounting Bracket, Aluminum 	6141A-6501	
For retroreflectors and retroreflective tape	See PG.05E.17.T.E	

 Stocked product, typical order quantities guaranteed in stock.

Wiring Diagram

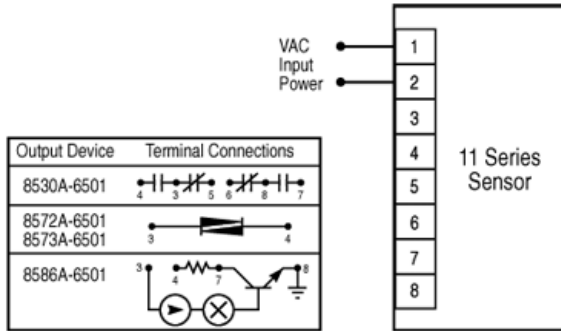

August 2007

Specifications — Sensors

Description	Specification
Operating Temperature	-5° to 130°F (-15° to +55°C)
Humidity	95% RH non-condensing
Material of Construction	Housing: Noryl® ①; Lens: Clear polycarbonate ①
Sunlight Immunity	10,000 foot-candles
Response Time	7 mS maximum
Vibration	2.5g or 0.06 inch displacement, whichever is less, over 20 Hz to 2 kHz
Sensitivity Adjustment	10:1 Ratio
Enclosure Ratings	NEMA 4 and 13 ②

- ① Avoid exposing lens and enclosure to chlorinated halogenated or aromatic hydrocarbons.
- ② NOTE: Our products conform to NEMA tests as indicated, however, some severe washdown applications can exceed these NEMA test specifications. If you have questions about a specific application, contact Eaton's Cutler-Hammer Sensor Applications Department at 1-800-426-9184.

Specifications — Output Devices

	DPDT Relays 8530A-6501	Traics		Isolated NPN Transistor
		Isolated	PC Compatible	
Operating Temperature	-4° to 131°F (-20° to 55°C)	-4° to 149°F (-20° to 65°C)	-4° to 149°F (-20° to 65°C)	-4° to 149°F (-20° to 65°C)
Response Time	25 mS maximum	1 mS maximum		Instantaneous
Off-to-On (pull-in) On-to-Off (drop-out)	25 mS maximum	1/2 cycle of line voltage		Instantaneous
Pull-In Voltage	8 – 9.6V	3V minimum	3V	3V
Drop-Out Voltage	1.2 – 2V	0.8V maximum	8V	1V

Approximate Dimensions in Inches

