

# Pad-Mounted Transformers

## Contents

### Pad-Mounted Transformers

General Description .....	17.0-2
Introduction .....	17.0-2
Application .....	17.0-2
Industry Standards .....	17.0-2
Ratings .....	17.0-2
Design Impedances .....	17.0-2
Application Limitations .....	17.0-2
Standard Features .....	17.0-3
Options .....	17.0-3
Primary Protection Options .....	17.0-4
Primary Switching Options .....	17.0-6
Loadbreak Wells and Inserts .....	17.0-7
Primary Fuse Details .....	17.0-8
Layout Dimensions .....	17.0-9
Dimensional Variations .....	17.0-9

### Specifications

See Eaton's Cutler-Hammer Product Specification Guide on enclosed CD-ROM:

CSI Format .....	1995	2004
	<b>Section 16321</b>	<b>Section 26 12 19</b>



*Typical Pad-Mounted Transformer*

General Description

Three-Phase Pad-Mounted Transformers



Typical Pad-Mounted Transformer

Introduction

Eaton's Cutler-Hammer® Three-Phase Pad-Mounted Transformer is offered in a variety of designs and configurations. The following pages describe the standard designs and common options that are available.

Some special designs and options may require additional engineering, factory coordination, unusual application requirements, or special manufacturing needs.

Higher impedances limit secondary fault currents such that coordination with secondary LV molded case circuit breakers is usually possible. (Low impedances are also available if required for paralleling, etc.)

Standard colors are pad-mounted green [Munsell® Green (#7GY3.29/1.5)]. ANSI #24, 61 and 70 are available as options.

Application

Liquid-filled, 3-phase, commercial pad-mounted distribution transformers are designed for servicing such underground distribution loads as shopping centers, schools, institutions and industrial plants. They are available in both livefront and deadfront construction, for radial or loop feed applications, with or without taps.

Industry Standards

Pad-mounted transformers meet industry standards: IEEE C57.12.00, IEEE C57.12.34, IEEE C57.12.28, IEEE C57.12.29, IEEE C57.12.70, IEEE C57.12.80, IEEE C57.12.90, IEEE C57.91 and NEMA®.

Ratings

- 75 – 5000 kVA.
- High voltages (primary):
 

4160 Grd. Y/2400	2400Δ
through	through
34,500 Grd. Y/19,920	34,500Δ
- HV Taps: 2 – 2-1/2% above and below normal, or 4 – 2-1/2% below normal.
- Standard BIL levels:
 

<b>kV Class</b>	<b>BIL (kV)</b>
1.2	30
2.5	45
5.0	60
8.7	75
15.0	95
25.0 Grd. Y Only	125
25.0	150
34.5 Grd. Y Only	150
34.5	150
- Low voltages (secondary).  
All voltages through 5 kV class.
- UL labeling available.
- Factory Mutual labeling available.

Design Impedances

Impedances are supplied to meet IEEE C57.12.00 standards. Customer specified impedances are available. (Subject to IEEE/ANSI ±7.5% impedance tolerance.)

■ Typical design impedances:	
<b>kVA</b>	<b>%Z</b>
75	4.00
112-1/2	4.00
150	4.00
225	4.00
300	5.00
500	5.00
750	5.75
1000	5.75
1500	5.75
2000	5.75
2500	5.75
3000	5.75
3750	5.75
5000	5.75

**Note:** Subject to NEMA/IEEE ±7.5% impedance tolerance.

**Note: Non-standard design impedance** may be obtained by contacting Eaton.

Application Limitations

The transformers described herein are designed for the application conditions normally encountered on electric power distribution systems. As such, they are suitable for use under the "usual service conditions" described in IEEE Standard C57.12.00 general requirements for liquid-immersed distribution, power and regulating transformers.

Consult Eaton for unusual service conditions such as:

- Abnormal environmental conditions.
- Unusual transient voltages present on the source voltage.
- Frequent or planned through-fault duty.
- Planned overloading unless in strict accordance with the IEEE loading guide (C57.91).
- Motors whose horsepower rating is greater than half the transformer kVA rating.
- Unusual frequency of impact loading may occur when supplying welding apparatus, electric arc furnaces, or motors with cyclical loads.
- Loads involving abnormal harmonic or dc current which may result where appreciable load currents are controlled by solid state or similar devices.

These lists do not purport to cover all unusual conditions and applicable limitations. Other "unusual service conditions" are described in IEEE Standard C57.12.00.

Table 17.0-1. Temperature Guarantees

Description	Ambient ①	Rise ②③
Standard	30°C	65°C
Optional	30°C	55°C

- ① 30°C average ambient temperature of cooling air not to exceed 40°C maximum over any 24 hour period.
- ② Degree rise is the average winding temperature rise by resistance.
- ③ A dual temperature rating of 55°/65°C adds 12% additional continuous capacity to the base kVA rating of the transformer.

**Note:** Altitudes not to exceed 3,300 feet (1,006 m).

Fluids — Liquid Dielectric

The choice of fluid, mineral oil or vegetable oil (BIOTEMP®, Envirottemp FR3®) is made based upon site conditions and proximity to facility walls, windows and flammable structures and environmentally sensitive areas.

**Note:** For additional information about transformer applications and types of insulating fluids, see Section 14.

March 2009  
Sheet 17003

### General Description

## Standard Features

- ① Four lifting hooks.
- ② Bolted-on terminal compartment with removable front sill.
- ③ Hinged, lift-off cabinet doors.
- ④ Interlocked hex-head or penta-head bolt padlock handle operates a cam assembly which is part of the 3-point door latching mechanism.

Hex-head or penta-head bolts must be removed from the flange formed on the steel high/low barrier before the HV door can be opened — not shown.

Removable neutral ground strap — not shown.

- ⑤ Tank ground pads (1 in HV, 1 in LV).
- ⑥ Steel high/low voltage compartment barrier.
- ⑦ Nameplate.
- ⑧ Fill plug and self-actuating pressure relief device.
- ⑨ Externally operated no load tap changer.
- ⑩ Drain valve and sampling device.
- ⑪ Liquid level gauge

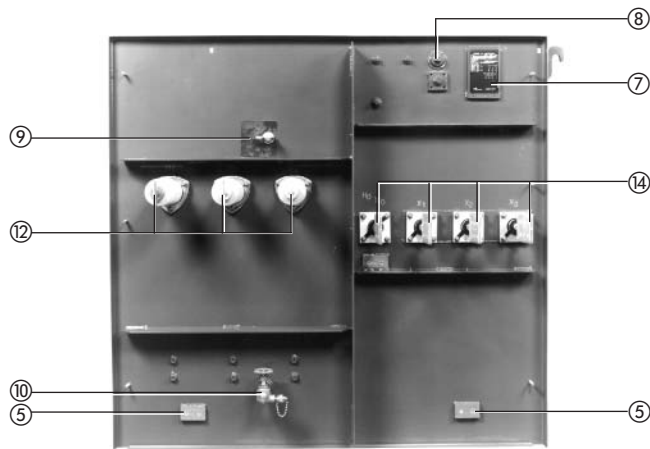
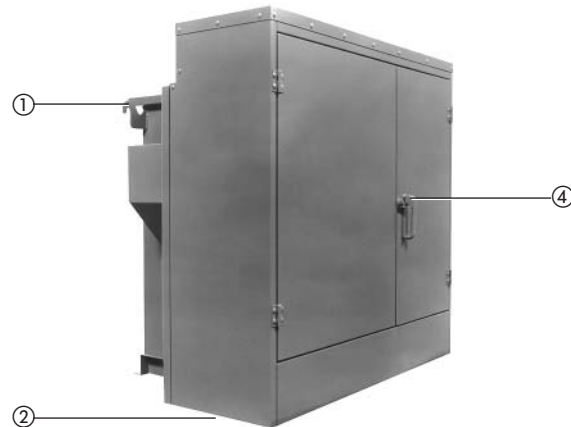

## Options

### Primary Termination

- ⑫ For livefront construction, externally clamped high voltage porcelain bushings double eye-bolt or spade for cable (75 – 225 kVA) or a single eyebolt or spade for cable (300 – 1500 kVA). Spade bushings are also offered.
- ⑬ For deadfront construction, externally clamped high-voltage epoxy bushing wells for 200 A loadbreak, or 600 A non-loadbreak inserts.

### Secondary Termination

- ⑭ NEMA spade terminals.

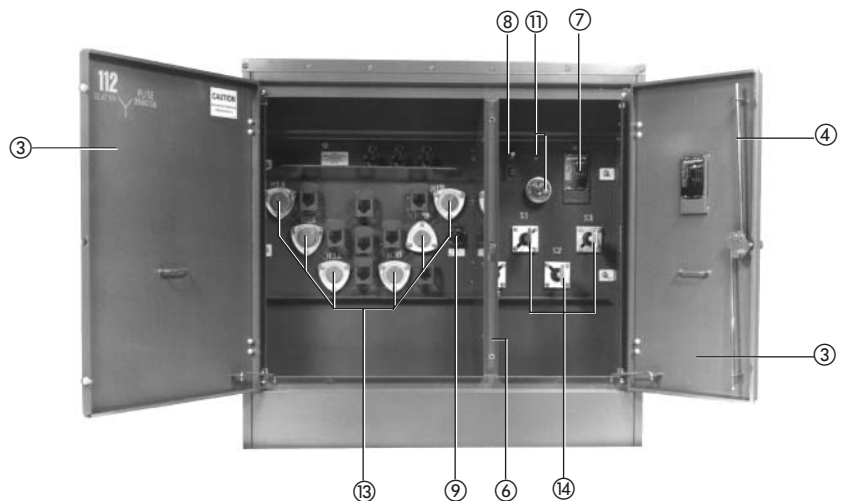

Primary and Secondary Compartment Features

General Description

**Primary Overcurrent Protection Options**

Primary protective devices are applied to distribution transformers in order to:

1. Prevent injury to personnel.
2. Prevent or minimize damage to equipment.
3. Improve the continuity of service by selectively controlling outages.

Factors which affect the protection scheme are:

1. Industry standard.
2. Customer's specification.
3. Customer's system configuration (available fault current, system voltage, system connection, etc.)
4. Availability of equipment.

The first consideration in determining the ampere rating of a fuse is to verify that the fuse in question is capable of withstanding typical inrush currents without element damage. When a transformer is energized, it is exposed to very large currents for very short periods of time, these currents are known as magnetizing inrush (or fuse withstand), and cold load pickup and are a result of the transformer's magnetic circuit, the electrical system configuration, and the connected load.

The second consideration for selecting the fuse ampere rating is the maximum load current the fuse is expected to carry without damage. Transformer fusing tables available from the manufacturer normally list the range of overload provided. If the longtime minimum melt current for a particular fuse size is known, it can be compared to the transformer rated current to determine the exact amount of overload permitted. An ambient of 25 – 40°C is generally assumed for application tables. Care should be taken when fuses are applied in higher ambient conditions, which will reduce the amount of overload permitted. An example of a high ambient condition used frequently in distribution transformers is that of current limiting fuses in dry-well canisters. To accommodate the overload and derating factors referred to, the following ratios are used on general-purpose CL fuses.

Nameplate current rating of fuse/nameplate current rating of transformer = 1.25 for enclosures surrounded by air (EFD, Clip mount, Arc-Strangler) or = 1.35 for enclosures surrounded by oil (canisters).

Derating factors are not applied to expulsion or backup CL fuses since high temperature has minimal effect on their operation.

Finally, it is necessary to verify that the fuse current rating under consideration will, in fact, operate prior to the transformer sustaining any permanent thermal damage (conductor or insulation burning or melting). This is done by comparing the total clearing characteristics of the fuse in question with the IEEE (I<sup>2</sup>t) damage line.

It is important that the total clearing characteristics of the device under consideration lie to the left of the damage line for all expected values of fault current. Note that most all fuse characteristics will cross the damage line at some point. It is important to make this occur at the lowest possible value of the current.

The interrupting rating of a device is a measure of the maximum symmetrical fault current at which the device can successfully clear a fault condition without excessive damage to itself, the equipment it is protecting, or the surrounding environment.

It is extremely critical that the interrupting rating of a device be greater than the maximum available symmetrical fault current. For devices applied to the transformer primary, the maximum fault current must be supplied by the utility since this value is dependent on the electrical system configuration.

**Protective Fuse Link**

- Internal, oil-immersed, expulsion type.
- Sized to operate only in the event of a winding failure, isolating the transformer from the primary system.
- Interrupting rating is 3500 A at 8.3 kV.



Protective Fuse Link

**Bay-O-Net-Type Fuse**

- Oil immersed, expulsion type.
- Drawout for fuse replacement.
- Hookstick operable, loadbreak design.
- Available with either overload-sensing or fault sensing.
- 3500 AIC at 8.3 kV, 1800 AIC at 15.5 kV.

Bay-O-Net fuse assemblies are used to protect transformers and distribution systems. They are designed for use in pad-mounted or sub-surface distribution transformers filled with transformer oil or approved equivalent. The assemblies combine the ease of hotstick operation with the safety of deadfront construction.

Removal of the fuse holder from the assembly indicates that the apparatus is electrically disconnected. It also allows convenient fuse element inspection and replacement. When typical safety practices are followed, the assemblies can be load-break operated for working on the transformer secondary; changing distribution voltage with dual voltage switches or tap changers; or disconnecting the apparatus from the line.

The optional Flapper™ Bay-O-Net Assembly (available as sidewall-mounted only) includes a flapper valve inside the housing, which closes when the fuse holder is removed, thus minimizing oil spillage.

Table 17.0-2. Bay-O-Net Fuse Electrical Ratings

kV Rating	Specification
150 50	BIL and Full Wave Crest 60 Hz, ac, 1-Minute Withstand
<b>Electrical Ratings</b>	
8.3	3000 Amperes rms Asymmetrical — Cover Mount 3500 Amperes rms Symmetrical — Sidewall Mount
15.5	2500 Amperes rms Asymmetrical — Cover Mount 2500 Amperes rms Symmetrical — Sidewall Mount ②
23.0	1000 Amperes rms Asymmetrical — Cover Mount 1000 Amperes rms Symmetrical — Sidewall Mount
<b>Load Break Ratings (Phase-to-Phase at 80% PF)</b>	
10.0	160 Amperes
15.5	150 Amperes
26.7	80 Amperes
34.5	50 Amperes

① With RTE Bay-O-Net fuse links only.  
② Except high ampere overload links, which are rated at 2000 amperes symmetrical.



Bay-O-Net-Type Fuse Assembly

General Description

**Current Limiting Fuses**

- Air immersed in drywell canister.
- Drawout for fuse replacement.
- Hookstick operable.
- Limits both the current magnitude and energy associated with low impedance faults.
- Effective in minimizing the probability of tank rupture due to internal, high energy, low impedance faults.
- Available fuse interrupting ratings of 25,000 or 50,000 amperes rms (symmetrical).
- Maximum fuse ampere rating at 15 kV (2 – 50 ampere fuses).

**Table 17.0-3. Current-Limiting Backup Fuse Electrical Ratings and Characteristics**

Fuse Type	Maximum Interrupting Current
Backup (Partial Range) "C" Rated	50,000 Amperes rms symmetrical ①

① See Table 17.0-5 for fuses with ratings other than 50,000 amperes rms symmetrical.



*Drawout Current Limiting Fuse Canister*



*Drawout Current Limiting Fuse Loadbreak Assembly*

**Partial Range Current Limiting Fuses**

- Oil immersed, internally block mounted.
- Applied in series with an expulsion type fuse (Bayonet-type see above).
- Protection against tank rupture.

The current-limiting backup fuse is used in series with low-current primary protection devices such as a Bay-O-Net Fuse.

The fuse's highly efficient current-limiting section minimizes the effects of high fault current stresses on equipment and the distribution system. Its minimum interrupting rating is coordinated with that of a low current interrupter to avoid undesirable low current operation; yet its maximum interrupting rating will clear the highest fault currents likely to occur. Higher continuous current ratings can be achieved by connecting two fuses in parallel.

The current-limiting fuse is used in transformers to protect and isolate faulted equipment. When connected in series with a low current primary protection device, the fuse becomes an element of a two-part protection system that gives a full range of fault protection.

This two-part system provides low current protection with the replaceable expulsion fuse and it adds the energy-

limiting protection of a current-limiting fuse. Together, they coordinate easily with upstream and downstream devices.

**Table 17.0-4. Two- and Four-Position, Load Break, Sectionalizing Switch**

Ratings	200 Ampere	300 Ampere	600 Ampere
Voltage kV Phase — Phase Maximum	35	25	15
Voltage kV Phase — Ground Maximum	21.1	15.2	8.3
Impulse Withstand kV	150	125	95
60 Hz 1 minute Withstand kV	50	40	34
Continuous Current	200	300	600
Loadbreak	200	300	600
Momentary, 10 Hz Two-Second	10,000	10,000	15,000
3-Shot Make and Latch Ampere	10,000	10,000	10,000
	6,000	10,000	10,000

**Table 17.0-5. Current-Limiting Backup Fuse Interrupting Ratings**

Continuous Ampere Current Rating	Minimum Interrupting Capacity (Amperes)	Minimum Melt I <sup>2</sup> t (A <sup>2</sup> x s)	Maximum Clear I <sup>2</sup> t (A <sup>2</sup> x s)
----------------------------------	---	--	---

**8.3 kV ②**

30	100	1,200	5,800
40	125	1,800	8,200
50	165	4,100	16,500
65	300	6,200	26,700
80	200	9,600	42,900
100	350	17,100	62,000
125	375	30,500	97,800
150	450	43,900	148,000
165	500	68,600	245,000
250 ③	800	122,000	369,000
300 ③	1000	175,600	566,000
330 ③	1200	274,400	875,700

**15.5 kV ④**

30	100	1,200	7,600
40	150	1,800	11,000
50	200	4,100	23,000
65	350	6,200	33,000
80	250	9,600	52,900
100	350	17,100	93,800
125	400	30,500	125,700
150	450	43,900	162,300
165	—	—	—
250 ③	800	122,000	408,000
300 ③	1000	175,600	660,700
330 ③	—	—	—

**23 kV ⑤**

30	125	1,200	10,500
40	200	1,800	15,100
50	325	4,100	34,300
65	400	6,200	38,400
80	300	9,600	68,300
100	400	17,100	121,000
125	500	30,500	149,700
150	600	43,900	196,700
165	700	68,600	307,300
250 ④	900	122,000	391,100
300 ④	1200	175,600	563,000
330 ④	1400	274,400	882,000

② The 8.3 kV, 30 – 100 ampere ratings have been tested and approved for application at 9.9 kV. The maximum interrupting capacity for the 65 – 100 ampere ratings at 9.9 kV is 18 kA.

③ Parallel fuses.

④ The 15.5 kV, 30 – 125 ampere and 250 ampere ratings have been tested and approved for application at 17.2 kV. The maximum interrupting rating for the 15.5 kV fuse, 30 – 125 amperes at 17.2 kV is 43 kA. For the 15 kV, 250 ampere fuse at 17.2 kV, the maximum interrupting rating is 12 kA.

⑤ The maximum interrupting rating for the 23 kV fuse, 80 – 165 amperes, 300 and 330 amperes, is 30 kA. For the 23 kV, 250 ampere fuse, the maximum interrupting rating is 12 kA.

General Description

**Primary Switching Options**

Eaton's Cutler-Hammer oil immersed switches are available for radial or loop feed system switching in three current ratings. The 3-phase gang operated switch has a spring loaded mechanism for loadbreak and latch operation. The switch is mounted near the core and coil assembly, for low cable capacitance; and with simultaneous 3-phase switching, the possibility of ferroresonance is reduced. Available in ratings through 600 A at 15 kV, 300 A at 25 kV, and 200 A at 35 kV.

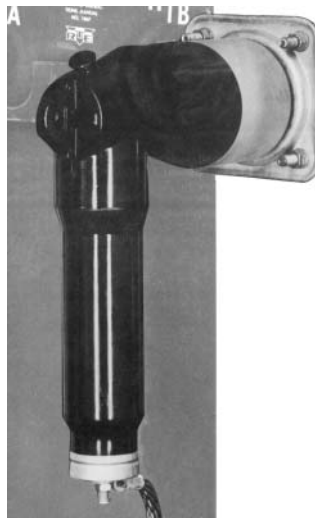

*Deadfront Elbow Arrester*

**Metal Oxide Varistor (MOV) Deadfront Arrester**

Surge Protection is available without losing deadfront construction in the cabinet. The Cutler-Hammer type MOV arrester is completely deadfront. It is compact, and is usable wherever a loadbreak elbow can be used.

The highly non-linear characteristics of the varistor elements provide more precise and predictable operating characteristics. The MOV arrester is capable of withstanding temporary overvoltages, so that ratings can be reduced, providing improved margins of protection.

Since it is fully shielded, and dead-front, it is mountable at any angle and submersible. Its durable rubber construction means there are no fragile porcelain skirts to chip or crack. The MOV arrester is available in ratings from 3 kV to 27 kV.

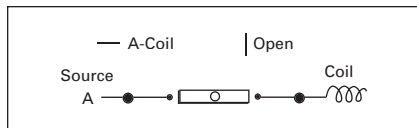

**Figure 17.0-1. Two-Position Switch**

**Surge Arresters**

Cutler-Hammer distribution class surge arresters are supplied on transformers when specified. Transformers with livefront configuration have mounting nuts welded on the tank wall for arrester mounting.

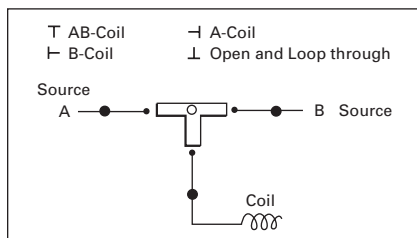

**Figure 17.0-2. Four-Position Switch (Loop Feed) "T Blade"**

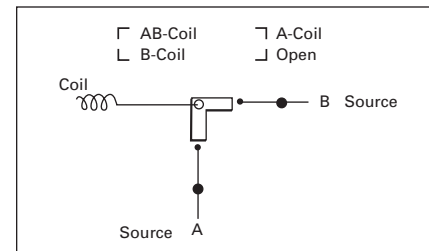

**Figure 17.0-3. Four-Position Switch (Loop Feed) "V Blade"**

March 2009  
Sheet 17007

### General Description

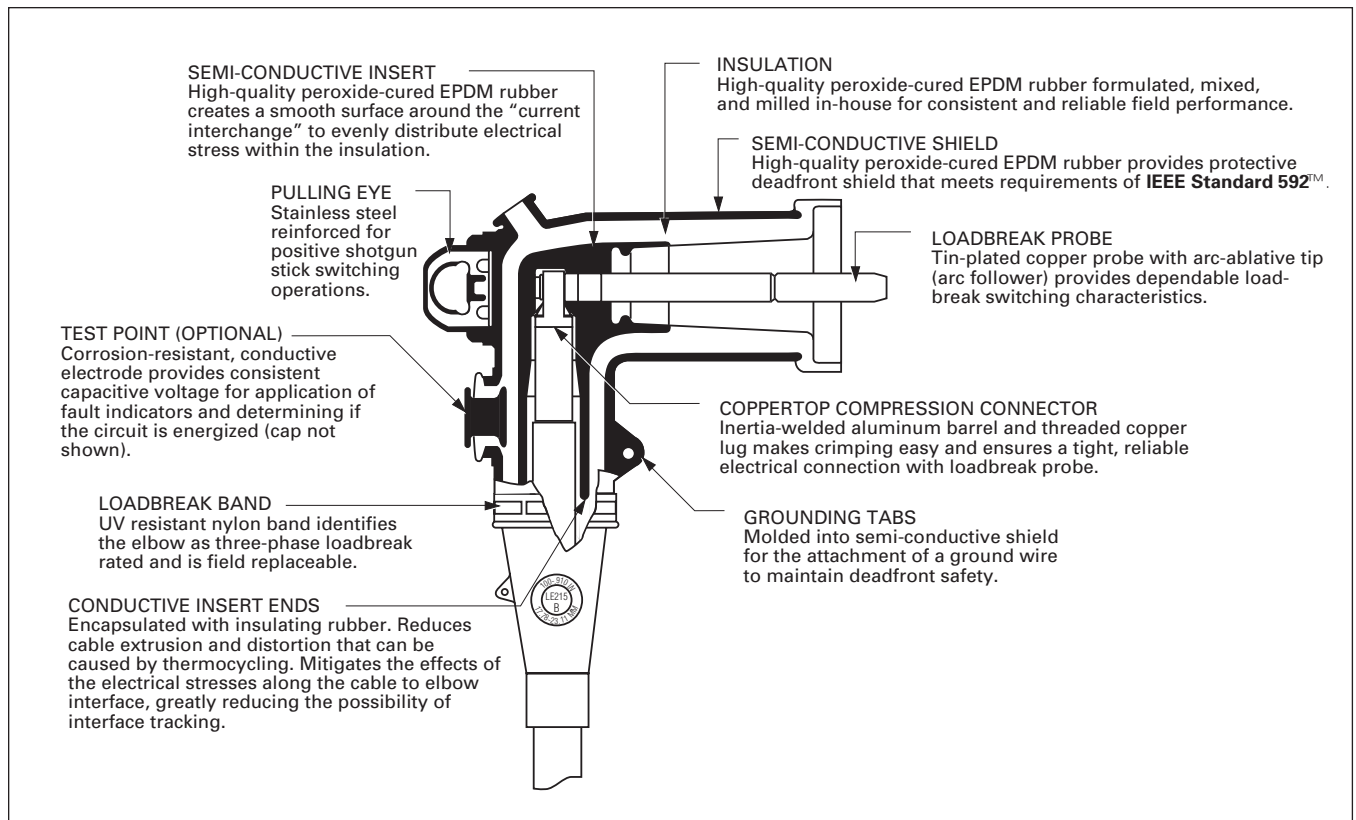

Figure 17.0-4. 200 Ampere, 15 kV Class Loadbreak Elbow Connector

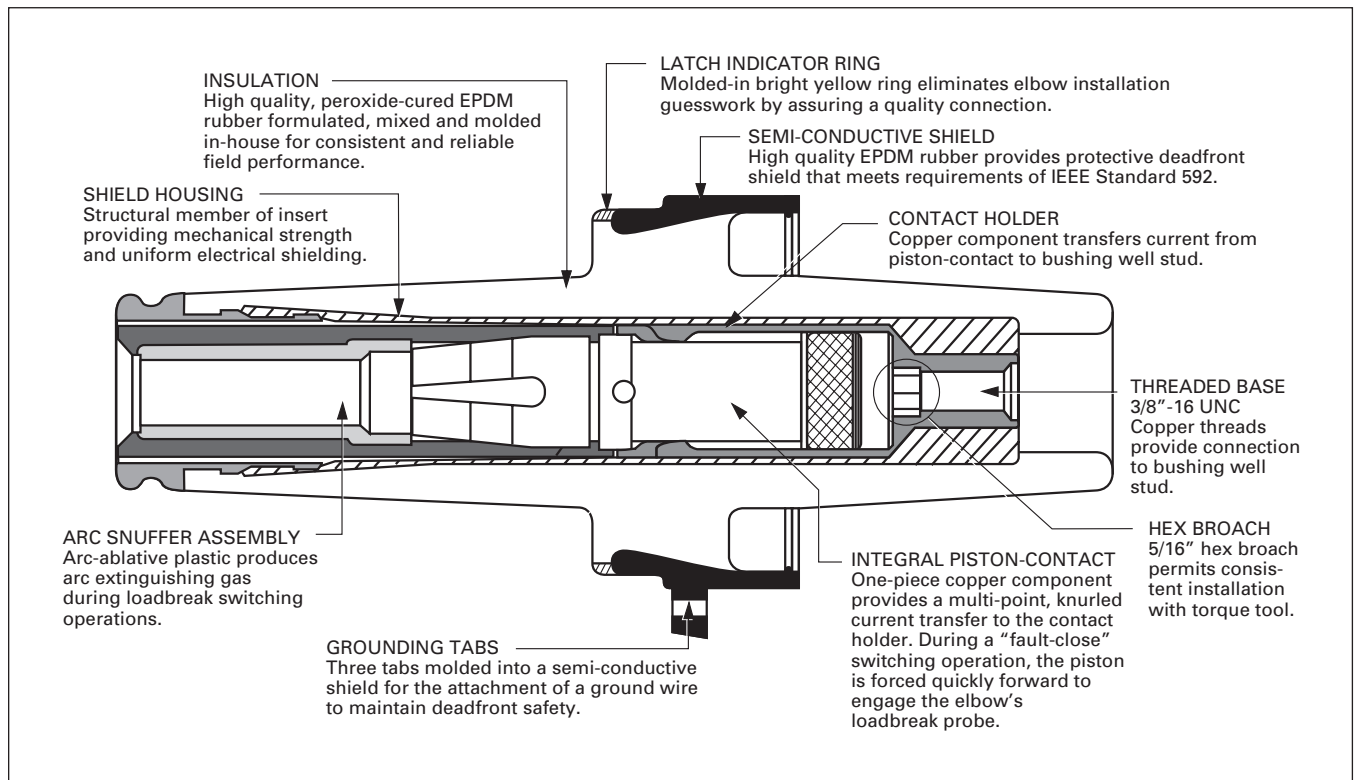

Figure 17.0-5. Bushing Well Insert Cutaway Illustrates Uncomplicated Nature of Current Path

General Description

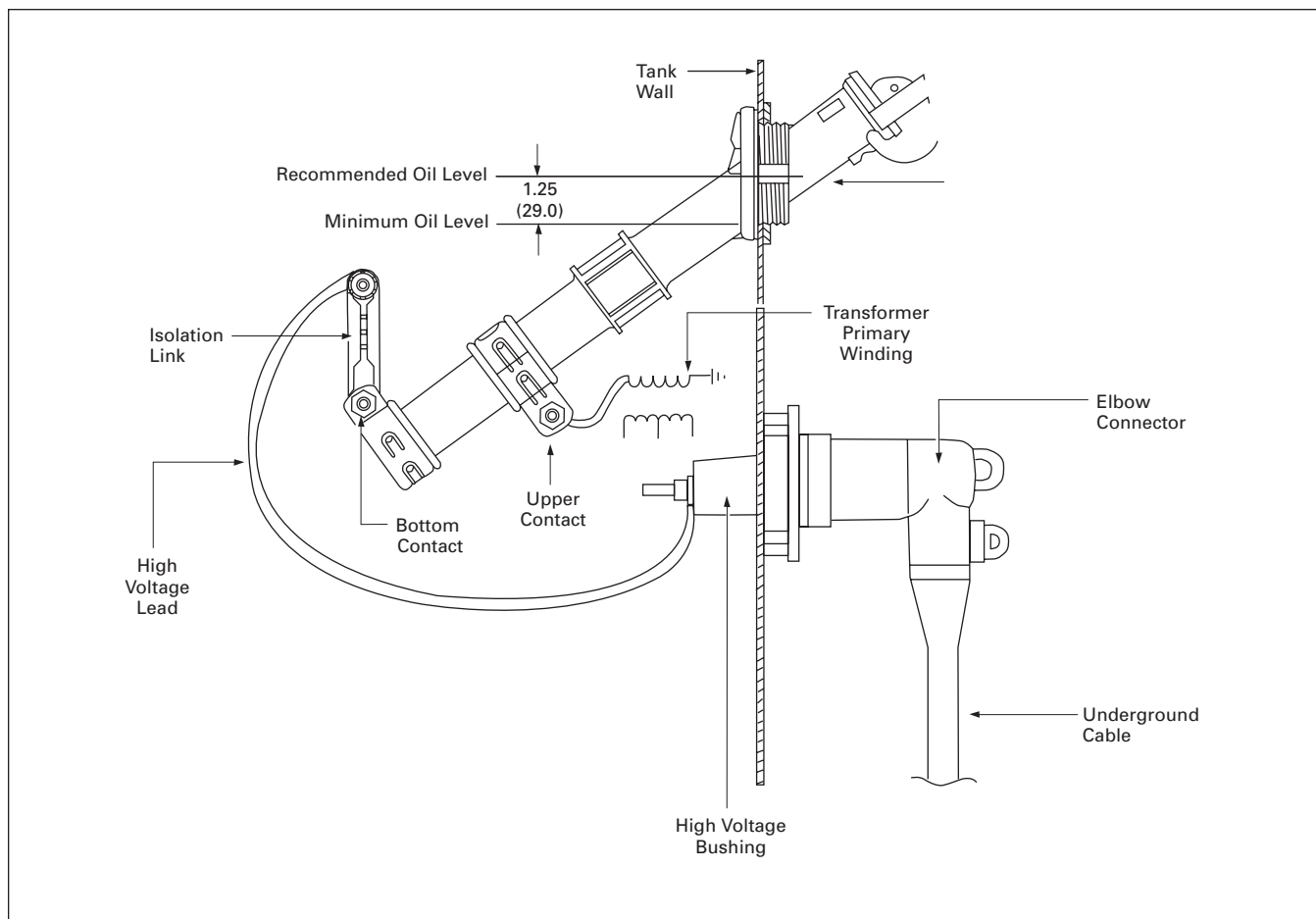

Figure 17.0-6. Bay-O-Net Assembly with Isolation Link

Note: Isolation link is not required if the Bay-O-Net fuse is used in series with a backup energy limiting fuse.

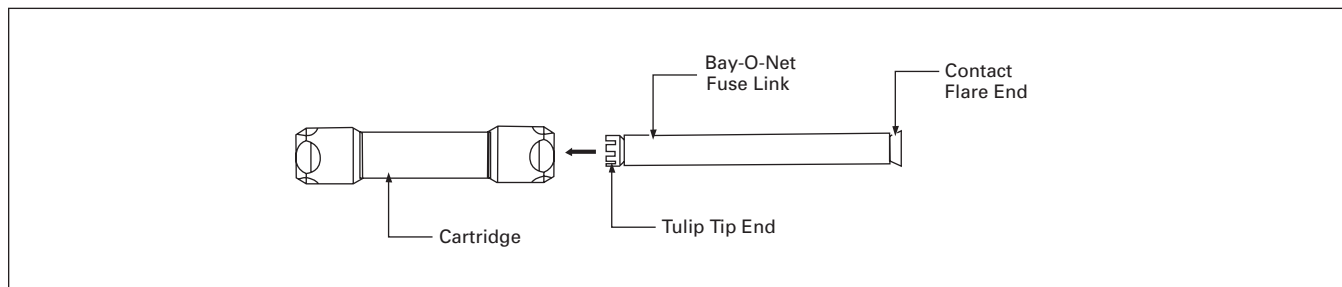

Figure 17.0-7. Insertion of Bay-O-Net Into Cartridge

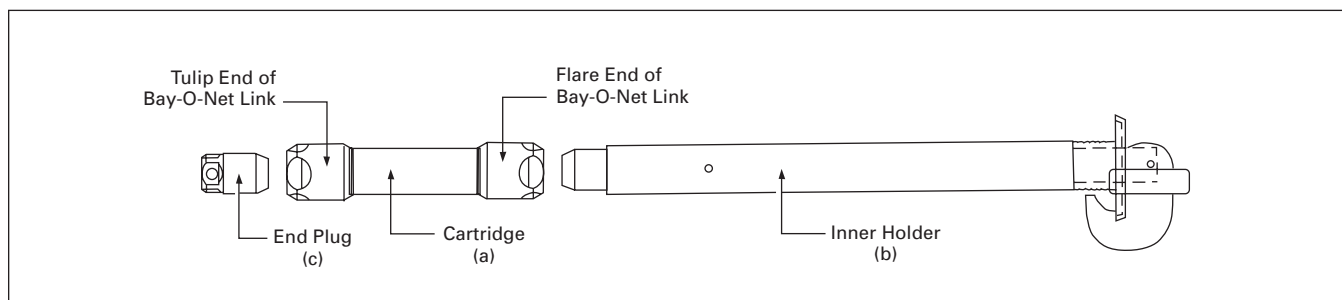

Figure 17.0-8. Assembly of Cartridge with Fuse Onto Inner Holder

Layout Dimensions

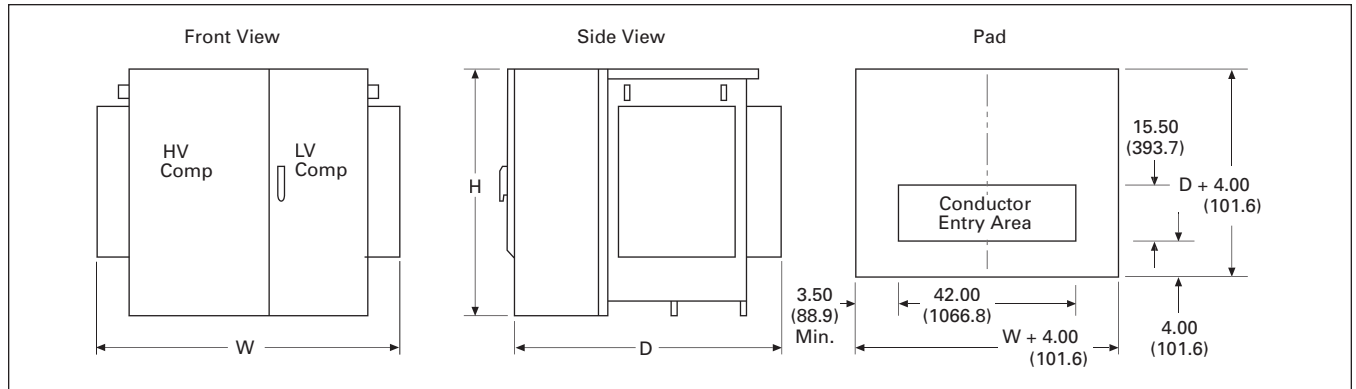

Figure 17.0-9. Pad-Mounted Transformer (75 – 2500 kVA) — Dimensions in Inches (mm)

Table 17.0-6. Standard Unit, Oil-Immersed 65°C Rise, 75 – 2500 kVA — Dimensions in Inches (mm)

kVA	Transformer Dimensions			Approximate Weight Lbs. (kg)	Gallons (Liters) of Oil (Approximate)
	Width (W)	Depth (D)	Height (H)		
<b>High Voltage: 5 – 15 kV Radial Feed, Livefront</b>					
75 – 150	68.00 (1727.2)	52.00 (1320.8)	55.00 (1397.0)	3500 (1589)	135 (511)
225 – 300	72.00 (1828.8)	54.00 (1371.6)	55.00 (1397.0)	4500 (2043)	185 (700)
500	72.00 (1828.8)	56.00 (1422.4)	55.00 (1397.0)	6000 (2724)	190 (719)
750	89.00 (2260.6)	62.00 (1574.8)	64.00 (1625.6)	9200 (4177)	360 (1363)
1000	89.00 (2260.6)	66.00 (1676.4)	72.00 (1828.8)	10,000 (4540)	415 (1571)
1500	89.00 (2260.6)	70.00 (1778.0)	72.00 (1828.8)	11,000 (4994)	455 (1722)
2000	92.00 (2336.8)	91.00 (2311.4)	72.00 (1828.8)	12,000 (5448)	510 (1930)
2500	98.00 (2489.2)	101.00 (2565.4)	72.00 (1828.8)	16,000 (7264)	530 (2006)
<b>High Voltage: 5 – 15 kV Radial Feed, Deadfront</b>					
75 – 150	68.00 (1727.2)	52.00 (1320.8)	55.00 (1397.0)	3500 (1589)	135 (511)
225 – 300	72.00 (1828.8)	54.00 (1371.6)	55.00 (1397.0)	4500 (2043)	185 (700)
500	72.00 (1828.8)	56.00 (1422.4)	55.00 (1397.0)	6000 (2724)	190 (719)
750	89.00 (2260.6)	62.00 (1574.8)	64.00 (1625.6)	9200 (4177)	360 (1363)
1000	89.00 (2260.6)	66.00 (1676.4)	72.00 (1828.8)	10,000 (4540)	415 (1571)
1500	89.00 (2260.6)	70.00 (1778.0)	72.00 (1828.8)	11,000 (4994)	455 (1722)
2000	92.00 (2336.8)	91.00 (2311.4)	72.00 (1828.8)	12,000 (5448)	510 (1930)
2500	98.00 (2489.2)	101.00 (2565.4)	72.00 (1828.8)	16,000 (7264)	530 (2006)
<b>High Voltage: 5 – 15 kV Loop Feed, Deadfront</b>					
75 – 150	68.00 (1727.2)	52.00 (1320.8)	55.00 (1397.0)	3500 (1589)	135 (511)
225 – 300	72.00 (1828.8)	54.00 (1371.6)	55.00 (1397.0)	4500 (2043)	185 (700)
500	72.00 (1828.8)	56.00 (1422.4)	55.00 (1397.0)	6000 (2724)	190 (719)
750	89.00 (2260.6)	62.00 (1574.8)	64.00 (1625.6)	9200 (4177)	360 (1363)
1000	89.00 (2260.6)	66.00 (1676.4)	72.00 (1828.8)	10,000 (4540)	415 (1571)
1500	89.00 (2260.6)	70.00 (1778.0)	72.00 (1828.8)	11,000 (4994)	455 (1722)
2000	92.00 (2336.8)	91.00 (2311.4)	72.00 (1828.8)	12,000 (5448)	510 (1930)
2500	98.00 (2489.2)	101.00 (2565.4)	72.00 (1828.8)	16,000 (7264)	530 (2006)
<b>High Voltage: 25 kV Radial Feed, Deadfront</b>					
75 – 150	68.00 (1727.2)	52.00 (1320.8)	55.00 (1397.0)	3500 (1589)	135 (511)
225 – 300	72.00 (1828.8)	54.00 (1371.6)	55.00 (1397.0)	4500 (2043)	185 (700)
500	72.00 (1828.8)	56.00 (1422.4)	55.00 (1397.0)	6000 (2724)	190 (719)
750	89.00 (2260.6)	62.00 (1574.8)	64.00 (1625.6)	9200 (4177)	360 (1363)
1000	89.00 (2260.6)	66.00 (1676.4)	72.00 (1828.8)	10,000 (4540)	415 (1571)
1500	89.00 (2260.6)	70.00 (1778.0)	72.00 (1828.8)	11,000 (4994)	455 (1722)
2000	92.00 (2336.8)	91.00 (2311.4)	72.00 (1828.8)	12,000 (5448)	510 (1930)
2500	98.00 (2489.2)	101.00 (2565.4)	72.00 (1828.8)	16,000 (7264)	530 (2006)
<b>High Voltage: 25 kV Loop Feed, Deadfront</b>					
75 – 150	68.00 (1727.2)	52.00 (1320.8)	55.00 (1397.0)	3500 (1589)	135 (511)
225 – 300	72.00 (1828.8)	54.00 (1371.6)	55.00 (1397.0)	4500 (2043)	185 (700)
500	72.00 (1828.8)	56.00 (1422.4)	55.00 (1397.0)	6000 (2724)	190 (719)
750	89.00 (2260.6)	62.00 (1574.8)	64.00 (1625.6)	9200 (4177)	360 (1363)
1000	89.00 (2260.6)	66.00 (1676.4)	72.00 (1828.8)	10,000 (4540)	415 (1571)
1500	89.00 (2260.6)	70.00 (1778.0)	72.00 (1828.8)	11,000 (4994)	455 (1722)
2000	92.00 (2336.8)	91.00 (2311.4)	72.00 (1828.8)	12,000 (5448)	510 (1930)
2500	98.00 (2489.2)	101.00 (2565.4)	72.00 (1828.8)	16,000 (7264)	530 (2006)

Dimensional Variations

Height Variations

1. Add 9 inches (228.6 mm) to the height when using bayonet fusing on all kVA ratings.
2. Add 7 inches (177.8 mm) to the height when using dry well canister fusing on 75 – 500 kVA ratings.
3. Add 8 inches (203.2 mm) to the height when using dry well canister fusing on 750 kVA rating only.

Depth Variations

4. Canister fuses require deeper tanks on some transformer sizes.
  - a. Add 4 inches (101.6 mm) to the depth of kVA ratings 75, 150 and 225.
  - b. Add 2 inches (50.8 mm) to the depth of kVA rating 300.
5. Vegetable oil fluid require deeper tanks on some transformer ratings.
  - a. Add 2 inches (50.8 mm) to the depth of kVA ratings 75 – 1500. Add 4 inches (101.6 mm) to the depth of kVA ratings 2000 and 2500.

BIOTEMP is a registered trademark of ABB, Inc. Envirotemp FR3 is a registered trademark of Cooper Power Systems Division and/or Cooper Industries, Inc. Cutler-Hammer is a federally registered trademark of Eaton Corporation. Munsell is a registered trademark of GretagMacbeth. NEMA is the registered trademark and service mark of the National Electrical Manufacturers Association.

Dimensions are approximate — not for construction.

Layout Dimensions

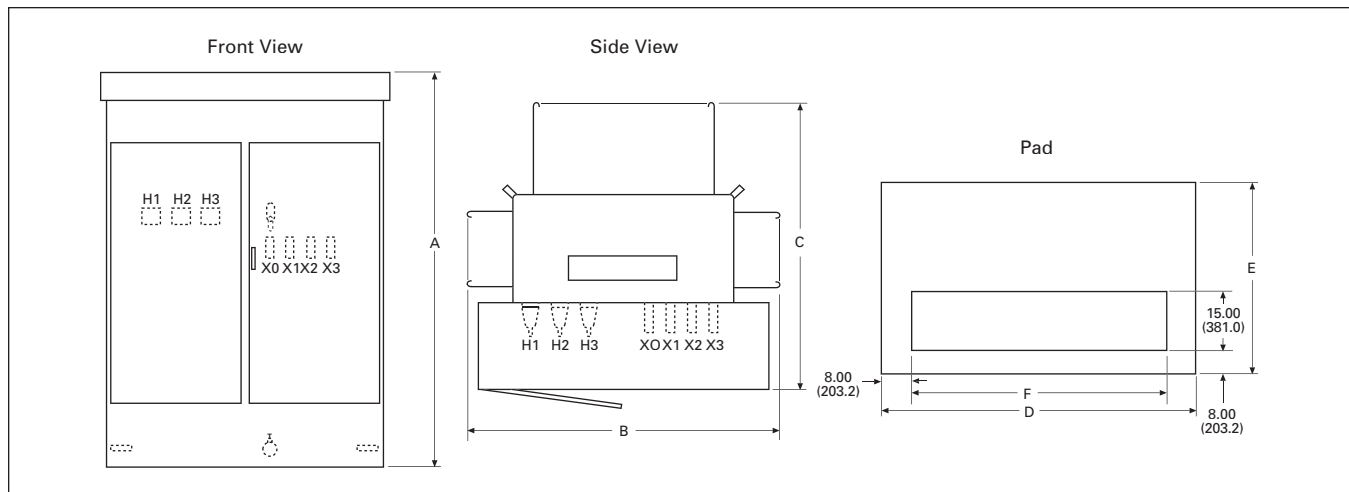

Figure 17.0-10. Pad-Mounted Transformer (3000 – 5000 kVA) — Dimensions in Inches (mm)

Table 17.0-7. Standard Unit, Oil-Immersed Rated 65°C Rise, 3000 – 5000 kVA — Dimensions in Inches (mm)

kVA	Transformer			Pad			Approximate Weight Lbs. (kg)	Gallons (Liters) of Oil
	A	B	C ①	D	E ②	F		
<b>15 kV Class, Delta Connected HV-HV 95 kV BIL, LV 30 kV BIL ③</b>								
3000	76.00 (1930.4)	119.00 (3022.6)	100.00 (2540.0)	74.00 (1879.6)	72.00 (1828.8)	58.00 (1473.2)	12,900 (5857)	385 (1457)
3750	80.00 (2032.0)	82.00 (2082.8)	111.00 (2819.4)	79.00 (2006.6)	83.00 (2108.2)	63.00 (1600.2)	20,000 (9080)	540 (2044)
5000	78.00 (1981.2)	137.00 (3479.8)	108.00 (2743.2)	76.00 (1930.4)	80.00 (2032.0)	60.00 (1524.0)	21,500 (9761)	565 (2139)
<b>15 kV Class, WYE Connected HV-HV 95 kV BIL, LV 30 kV BIL ③</b>								
3000	74.00 (1879.6)	117.00 (2971.8)	102.00 (2590.8)	78.00 (1981.2)	74.00 (1879.6)	62.00 (1574.8)	15,000 (6810)	390 (1476)
3750	97.00 (2463.8)	81.00 (2057.4)	101.00 (2565.4)	81.00 (2057.4)	77.00 (1955.8)	65.00 (1651.0)	21,800 (9897)	550 (2082)
5000	81.00 (2057.4)	119.00 (3022.6)	108.00 (2743.2)	84.00 (2133.6)	80.00 (2032.0)	68.00 (1727.2)	22,000 (9988)	585 (2214)
<b>25 kV Class, Delta Connected HV-HV 150 kV BIL, LV 30 kV BIL ③</b>								
3000	83.00 (2108.2)	84.00 (2133.6)	101.00 (2565.4)	86.00 (2184.4)	74.00 (1879.6)	70.00 (1778.0)	15,400 (6992)	515 (1949)
3750	96.00 (2438.4)	84.00 (2133.6)	98.00 (2489.2)	86.00 (2184.4)	78.00 (1981.2)	70.00 (1778.0)	20,100 (9125)	650 (2460)
5000	101.00 (2565.4)	101.00 (2565.4)	107.00 (2717.8)	84.00 (2133.6)	79.00 (2006.6)	68.00 (1727.2)	22,900 (10,397)	670 (2540)
<b>25 kV Class, WYE Connected HV-HV 125 kV BIL, LV 30 kV BIL ③</b>								
3000	84.00 (2133.6)	80.00 (2032.0)	102.00 (2590.8)	80.00 (2032.0)	74.00 (1879.6)	64.00 (1625.6)	16,300 (7400)	450 (1703)
3750	93.00 (2362.2)	85.00 (2159.0)	99.00 (2514.6)	84.00 (2133.6)	78.00 (1981.2)	68.00 (1727.2)	21,200 (9625)	575 (2176)
5000	90.00 (2286.0)	110.00 (2794.0)	108.00 (2743.2)	84.00 (2133.6)	80.00 (2032.0)	68.00 (1727.2)	23,100 (10,487)	605 (2290)
<b>35 kV Class, Delta Connected HV-HV 200 kV BIL, LV 30 kV BIL</b>								
3000	86.00 (2184.4)	104.00 (2641.6)	101.00 (2565.4)	107.00 (2717.8)	83.00 (2108.2)	91.00 (2311.4)	18,100 (8217)	755 (2858)
3750	86.00 (2184.4)	104.00 (2641.6)	106.00 (2692.4)	107.00 (2717.8)	88.00 (2235.2)	91.00 (2311.4)	21,500 (9761)	850 (3217)
5000	102.00 (2590.8)	102.00 (2590.8)	113.00 (2870.2)	105.00 (2667.0)	88.00 (2235.2)	89.00 (2260.6)	25,700 (11,668)	960 (3634)
<b>35 kV Class, WYE Connected HV-HV 125 kV BIL, LV 30 kV BIL</b>								
3000	82.00 (2082.8)	86.00 (2184.4)	101.00 (2565.4)	78.00 (1981.2)	73.00 (1854.2)	62.00 (1574.8)	15,700 (7128)	420 (2006)
3750	91.00 (2311.4)	82.00 (2082.8)	102.00 (2590.8)	82.00 (2082.8)	76.00 (1930.4)	66.00 (1676.4)	19,800 (8989)	525 (1987)
5000	92.00 (2336.8)	122.00 (3098.8)	106.00 (2692.4)	83.00 (2108.2)	78.00 (1981.2)	67.00 (1701.8)	22,600 (10,260)	580 (2195)
<b>35 kV Class, Delta Connected HV-HV 150 kV BIL, LV 30 kV BIL</b>								
3000	84.00 (2133.6)	84.00 (2133.6)	100.00 (2540.0)	86.00 (2184.4)	74.00 (1879.6)	70.00 (1778.0)	15,400 (6992)	530 (2006)
3750	84.00 (2133.6)	84.00 (2133.6)	101.00 (2565.4)	86.00 (2184.4)	77.00 (1955.8)	70.00 (1778.0)	19,300 (8762)	630 (2385)
5000	92.00 (2336.8)	122.00 (3098.8)	106.00 (2692.4)	81.00 (2057.4)	78.00 (1981.2)	65.00 (1651.0)	20,500 (9307)	600 (2271)
<b>35 kV Class, WYE Connected HV-HV 150 kV BIL, LV 30 kV BIL</b>								
3000	80.00 (2032.0)	84.00 (2133.6)	104.00 (2641.6)	86.00 (2184.4)	76.00 (1930.4)	70.00 (1778.0)	17,100 (7718)	500 (1893)
3750	86.00 (2184.4)	87.00 (2209.8)	107.00 (2717.8)	86.00 (2184.4)	79.00 (2006.6)	70.00 (1778.0)	20,600 (9352)	560 (2120)
5000	95.00 (2413.0)	105.00 (2667.0)	107.00 (2717.8)	85.00 (2159.0)	79.00 (2006.6)	69.00 (1752.6)	23,800 (10,805)	625 (2366)
<b>35 kV Class, WYE Connected HV-HV 200 kV BIL, LV 30 kV BIL</b>								
3000	88.00 (2235.2)	104.00 (2641.6)	99.00 (2514.6)	107.00 (2717.8)	83.00 (2108.2)	91.00 (2311.4)	19,800 (8989)	720 (2725)
3750	90.00 (2286.0)	104.00 (2641.6)	104.00 (2641.6)	107.00 (2717.8)	90.00 (2286.0)	91.00 (2311.4)	24,400 (11,078)	840 (3179)
5000	101.00 (2565.4)	102.00 (2590.8)	106.00 (2692.4)	105.00 (2667.0)	90.00 (2286.0)	89.00 (2260.6)	28,600 (12,984)	920 (3482)

① Standard compartment depth is 22 inches (558.8 mm) except 200 kV BIL has a depth of 30 inches (762.0 mm); Depth may be altered by the addition of switching and fusing.

② Extends under base of transformer only. Does not include rear coolers.

③ Standard low voltages are 480Y and 480Δ (through 3750 kVA only). Low voltage above 3750 kVA must be 2400 volts or above.

Dimensions are approximate — not for construction.