

Introduction

1

Contents

<i>Description</i>	<i>Page</i>
Welcome	1-2
Eaton Corporation	1-2
Technical Reference	1-2
Enclosure Types	1-2
Enclosure Ratings	1-3
Motor Circuit Elements	1-5
Power Supplies	1-5
Functions of Control	1-6
Two- and Three-Wire Control	1-7



Cutler-Hammer® Enclosed Control Products

1

Welcome

Welcome to the latest edition of the *Enclosed Control Product Guide* from Eaton's electrical business. In this updated edition, you will find complete details on our extensive line of Cutler-Hammer® Enclosed Products.

Eaton Corporation

Eaton Corporation is a diversified industrial manufacturer ranked among the largest Fortune 500 companies. The electrical group is Eaton's largest division and is a global leader in electrical control, power distribution, power quality, automation, and monitoring products and services. Eaton's electrical products include brands such as Cutler-Hammer®, MGE Office Protection Systems, Powerware®, Holec®, and MEM®. Eaton provides PowerChain Management® solutions to serve the needs of the industrial, institutional, IT, data center, mission critical, utility, residential and OEM markets worldwide.

PowerChain Management solutions help enterprises achieve sustainable and competitive advantages through proactive management of the power system as a strategic, integrated asset throughout its life cycle. With Eaton's distribution, generation and power quality equipment; full-scale engineering services; and information management systems, the power system is positioned to deliver powerful results: greater reliability, operating cost efficiencies, effective use of capital, enhanced safety, and risk mitigation.

Technical Reference**Enclosure Types**

Enclosures provide mechanical and electrical protection for operator and equipment. Brief descriptions of the various types of Cutler-Hammer enclosures offered by Eaton are given below. See NEMA Standards Publication No. 250 for more comprehensive descriptions, definitions and/or test criteria.

**Type 1****Type 1 (Conforms to IP40) — for Indoor Use**

Suitable for most applications where unusual service conditions do not exist and where a measure of protection from accidental contact with enclosed equipment is required. Designed to meet tests for rod entry and rust resistance. Enclosure is sheet steel, treated to resist corrosion. Depending on the size, knockouts are provided on the top, bottom and sometimes on the side.

**Type 3R****Type 3R (Conforms to IP52) — for Outdoor Use**

Primarily intended for applications where falling rain, sleet or external ice formations are present. Gasketed cover. Designed to meet tests for rain, rod entry, external icing and rust resistance. Enclosure is sheet steel, treated to resist corrosion. Depending on the size, a blank cover plate is attached to the top (for a conduit hub) and knockouts are provided on the bottom.

Cover-mounted pilot device holes are provided and covered with hole plugs.

Type 4 (Conforms to IP65) — for Indoor or Outdoor Use

Provide measure of protection from splashing water, hose-directed water and wind blown dust or rain. Constructed of sheet steel with gasketed cover.

Designed to meet tests for hose-down, external icing and corrosion protection. When conduit connections are specified, enclosure has two watertight hubs (power) installed top and bottom or one control hub installed in bottom — depending on size.

Cover-mounted pilot device holes are provided and covered with hole plugs.

**Type 4X****Type 4X (Conforms to IP65) — for Indoor or Outdoor Use**

Provide measure of protection from splashing water, hose-directed water, wind blown dust, rain and corrosion. Constructed of stainless steel with gasketed cover. Designed to meet same tests as Type 4 except enclosure must pass a 200-hour salt spray corrosion resistance test.

Provided as 304-grade stainless steel as standard. Select 316-grade option for improved corrosion resistance.



Type 7 & 9 Bolted

Type 7/9 — for Hazardous Gas Locations

For use in Class I, Group B, C or D; Class II, Groups E, F and Class III indoor locations as defined in the National Electrical Code. Type 7/9 enclosures must withstand the pressure generated by explosion of internally trapped gases and be able to contain the explosion so that gases in the surrounding atmosphere are not ignited. Under normal operation, the surface temperature of the enclosure must be below the point where it could ignite explosive gases present in the surrounding atmosphere. Designed to meet explosion, temperature and hydrostatic design tests.



Type 12

Type 12 — (Conforms to IP62) — for Indoor Use

Provide a degree of protection from dripping liquids (non-corrosive), falling dirt and dust. Designed to meet tests for drip, dust and rust resistance. Constructed of sheet steel. Hole plugs cover pilot device holes. There are no knockouts, hub cover plates or hubs installed.

Many Cutler-Hammer Type 12 enclosures are suitable for use in Class II, Division 2, Group G and Class III, Divisions 1 and 2 locations as defined in the National Electrical Code.

Type 12 — Safety Interlock

The Type 12 enclosure can be ordered with a safety interlock on the door that can be padlocked off. A vault-type door latch system is used. A tapered

plate holds the gasketed door tight against the case edge to provide a positive seal. The special door interlock consists of the door handle and a screwdriver operated cover defeater.

The cover defeater and the disconnect interlock defeater are both recessed screwdriver operated devices which cannot be manipulated with other types of tools.

Enclosure Ratings

Table 1-1. IEC IP Index of Protection Ratings

1st Number	Description	2nd Number	Description
0	No Protection	0	No Protection
1	Protection Against Solid Objects Greater than 50 mm	1	Protection Against Vertically Falling Drops of Water
2	Protection Against Solid Objects Greater than 12 mm	2	Protection Against Dripping Water When Tilted Up to 15 Degrees
3	Protection Against Solid Objects Greater than 2.5 mm	3	Protection Against Spraying Water
4	Protection Against Solid Objects Greater than 1 mm	4	Protection Against Splashing Water
5	Total Protection Against Dust — Limited Ingress (Dust Protected)	5	Protection Against Water Jets
6	Total Protection Against Dust (Dust-Tight)	6	Protection Against Heavy Seas
—	—	7	Protection Against the Effects of Immersion
—	—	8	Protection Against Submersion

The UL, NEMA and IEC organizations (and other international groups) define degrees of protection provided by electrical enclosures with respect to personnel, equipment within the housing and the ingress of water.

Subtle differences do exist between the test procedures and specifications of these organizations.

To claim ratings to NEMA Type specifications, the testing is performed and certified by the manufacturers themselves.

To comply to UL and IEC specifications, the manufacturers must submit product samples, materials used and other data to an independent testing laboratory before ratings can be claimed.

In addition, IEC "IP" ratings differ from NEMA Type in that they do not apply to protection against the risk of explosion or conditions such as humidity, corrosive gases, fungi or vermin. In addition, different parts of the equipment can have different degrees of protection and still comply.

Table 1-2 is a comparison of the NEMA/UL/IEC enclosure specifications to be used as an approximate reference only. **Do not use the table to convert from IEC to NEMA designations.**

1

Table 1-2. NEMA/UL/IEC Enclosure Type Cross-Reference — Approximate

NEMA Enclosure Rating	IP10	IP20	IP21	IP22	IP23	IP30	IP31	IP32	IP33	IP40	IP41	IP42	IP43	IP50	IP51	IP52	IP53	IP54	IP55	IP56	IP60	IP61	IP62	IP63	IP64	IP65	IP66	IP67	IP68
1	X	X	X	X	X																								
2	X	X	X	X	X																								
3	X	X	X	X	X	X	X	X	X	X	X	X	X	X	X	X	X	X	X	X	X	X	X	X	X				
3R	X	X	X	X	X	X	X	X																					
3S	X	X	X	X	X	X	X	X	X	X	X	X	X	X	X	X	X	X	X	X	X	X	X	X					
4	X	X	X	X	X	X	X	X	X	X	X	X	X	X	X	X	X	X	X	X	X	X	X	X	X	X	X		
4X	X	X	X	X	X	X	X	X	X	X	X	X	X	X	X	X	X	X	X	X	X	X	X	X	X	X	X		
6	X	X	X	X	X	X	X	X	X	X	X	X	X	X	X	X	X	X	X	X	X	X	X	X	X	X	X	X	
6P	X	X	X	X	X	X	X	X	X	X	X	X	X	X	X	X	X	X	X	X	X	X	X	X	X	X	X	X	
12	X	X	X	X	X	X	X	X	X	X	X	X	X	X	X	X	X	X	X	X	X	X	X	X	X	X			
13	X	X	X	X	X	X	X	X	X	X	X	X	X	X	X	X	X	X	X	X	X	X	X	X	X	X			

Note: IEC 529 does not specify equivalents to NEMA Enclosure Types 7, 8, 9 or 10.

Table 1-3. IEC Environmental Enclosure Ratings — Examples of Designations

<p style="text-align: center;">IP 4 4</p> <p>Characteristic letters _____</p> <p>1st characteristic numeral _____</p> <p>(See Table 1-2)</p> <p>2nd characteristic numeral _____</p> <p>(See Table 1-2)</p> <p>An enclosure with this designation is protected against the penetration of solid objects greater than 1.0 mm and against splashing water.</p>	<p style="text-align: center;">IP 2 3</p> <p>Characteristic letters _____</p> <p>1st characteristic numeral _____</p> <p>(See Table 1-2)</p> <p>2nd characteristic numeral _____</p> <p>(See Table 1-2)</p> <p>An enclosure with this designation is protected against the penetration of solid objects greater than 12 mm and against splashing water.</p>
---	--

Motor Circuit Elements

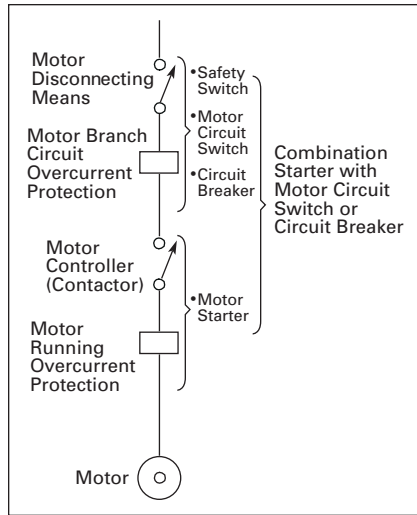

Figure 1-1. Typical Motor Circuit

DISCONNECT SWITCH — horsepower rated — located in sight of controller — arranged for padlocking in open position — disconnects motor and controller from ungrounded power conductors — position indicating — readily accessible — 115% carrying capacity of full load motor current — interrupting capacity of stalled motor current — may serve as disconnect for more than one motor if motors driving parts of single machine or motors all in single room within sight of disconnecting means, must equal sum of horsepower ratings to be disconnected — device may be general use switch, motor circuit switch or circuit breaker meeting code requirements — disconnecting means should contain motor branch-circuit short circuit and ground fault protection.

MOTOR RUNNING OVERCURRENT PROTECTION — called overload relay — protect motor and control apparatus against overheating due to motor overload — does not protect against short circuits or ground faults — selected to trip at not more than 125% full load motor current, 40°C rise motors — 115% all other motors — continuous duty motor protection — intermittent duty motors protected by branch circuit protection — sufficient time delay to permit motor to start and accelerate load without tripping — sensing devices (heater coils) in ungrounded conductor for single-phase — three sensing devices (heater coils) required for three-phase.

CONTACTOR — starting, stopping motor it controls — interrupt stalled motor current — horsepower rated — not lower than horsepower of motor controlled — contactor not in sight of connected motor must have disconnect capable of locking in open position or manually operable switch which will prevent contactor closing within sight of motor — interrupt all ungrounded power lines — manually or magnetically operated.

CONTROLLER OR STARTER — non-combination contains contactor and motor running overcurrent protection in one enclosure — starts, stops, protects and regulates motor — combination starters contain disconnecting means, branch short circuit protection in same enclosure. (See Motor Control Sections — three-phase, single-phase and DC.)

REDUCED VOLTAGE — restrictions in power supply capacity or machine design may require reduced voltage starting — motor connected to power supply at voltage lower than supply voltage — requires use of primary resistance, reactance or use of autotransformer — special motor designs such as part winding and wye-delta considered as reduced voltage starting.

Power Supplies

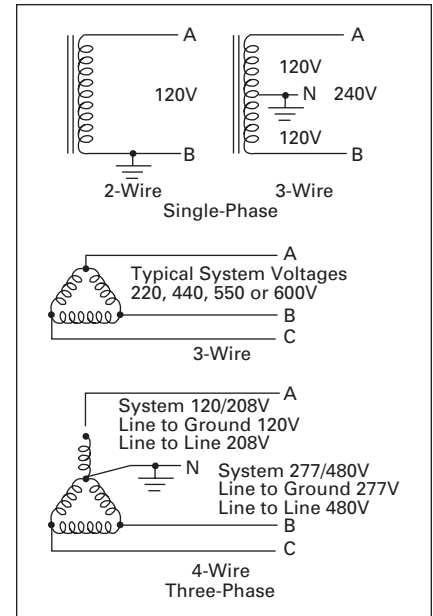

Figure 1-2. Single- and Three-Phase Power Supply

All electrical power supplied as AC or DC — primarily AC — generation, transmission and some distribution of power at high voltage — most power distribution at use voltage for industrial and residential is 600V and under — AC power generally at a frequency of 60 hertz — 50 and 25 hertz used in some specific areas — AC distribution at use location single- or three-phase — limited areas have two-phase — **SINGLE-PHASE** — two-wire, 120V one line grounded — 120/240V three-wire center line grounded — residential distribution, lighting, heat, fractional horsepower motors, business machines — **THREE-PHASE** — three-wire delta 220/440V, 550V — four-wire wye 120/208 and 277/480V neutral line grounded — primary industrial power distribution — main motor drives, integral horsepower motors, lighting, heating, fractional horsepower motors, business machines — used as three-phase or single-phase power supply.

1

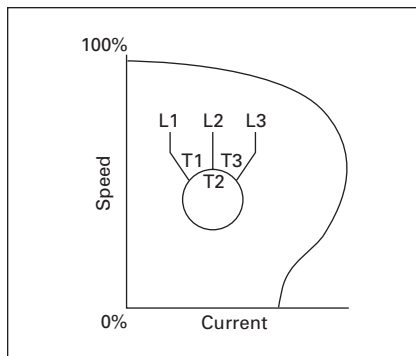

Figure 1-3. Squirrel Cage Speed

AC SQUIRREL CAGE MOTOR — single- or three-phase — single-phase requires starting winding — three-phase self-starting — stationary stator winding — no electrical connection to short circuited rotor — torque produced from magnetic reaction of stator and rotor fields — speed a function of supply frequency and number of electrical poles wound on stator — considered as constant speed even though speed decreases slightly with increased load — high inrush currents during starting on full voltage — rugged construction — easily serviced and maintained — high efficiency — good running power factor when delivering full load — requires motor control only for stator windings.

Functions of Control

Controller functions to start, stop, reverse, regulate and protect connected motor — when functions do not include speed regulation, device is known as a starter rather than controller — **general** applications of control functions on fans, pumps, heating and applications of variable torque and horsepower where relatively infrequent cycling is necessary — functions usually starting and stopping with or without motor running overcurrent protection — manual or magnetic control — **Commercial and Industrial** control functions for constant horsepower, constant or variable torque machine loads, constant torque metal working machinery, variable torque and horsepower fans and blowers, constant power heating, lighting, pumps and motors for all types of applications — may include speed regulation — good for cycling or infrequent starting and stopping — manual or magnetic.

Remote and Local Control

Local Control — controlling or sensing device, master switch or pilot device initiating operation located in same enclosure as controller.

Remote Control — controlling devices located at some other point than controller — may have more than one operating point with control devices connected in parallel or in series, depending on operating sequence required.

Wiring Diagrams

A symbolic representation of operation and function of control devices.

Jogging, Inching, Plugging Service

Jogging or inching — momentary operation of driven machine for small movement or positioning — requires non-maintained operator and electrical control circuit — control subject to motor inrush current on each jog or inch cycle — contactor derated where the contactor is opened or closed more than five times per minute or more than ten times in a 10-minute period.

Plugging — plugging stop or plugging reverse — reverse power supplied to motor — motor generates braking — contactors subjected to higher than normal motor inrush during plugging — requires reversing contactors — contactor derated for plugging service.

Two- and Three-Wire Control

Two-Wire Control

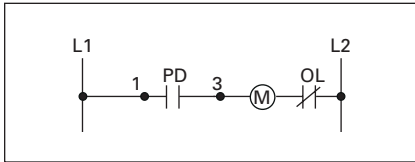

Figure 1-4. Two-Wire Wiring

Two-wire control is a control function which utilizes a maintained contact type of pilot device to provide low voltage release (LVR).

Three-Wire Control

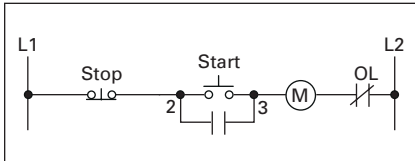

Figure 1-5. Three-Wire Wiring

Three-wire control is a control function which utilizes a momentary contact pilot device and a holding circuit to provide low voltage protection (LVP).

Panel Diagram — wiring, panel and pilot device layout — actual position of devices — power line bold and control lines light — circuit symbols show basic construction details.

Line Diagram — connection representation but not wiring configuration — sequence and function of devices but not location — symbols do not represent physical construction of device.

Remote Pilot Devices

2-Wire Control

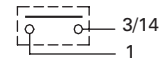

Not for Use with Auto Reset OL Relays

3-Wire Control

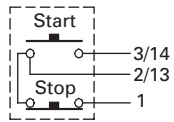

When More Than One Pushbutton Station Is Used, Omit Connector "A" and Connect per Sketch Below

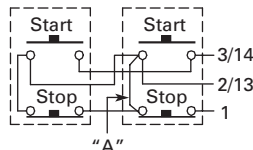

Separate Control

Remove Wire "C" if Supplied and Connect Separate Control Lines to the Number 1 Terminal on the Remote Pilot Device and to the Number 96 Terminal on the Overload Relay.

Connections for Non-reversing Starter

Figure 1
Front View of Panel

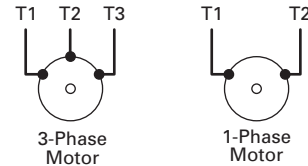
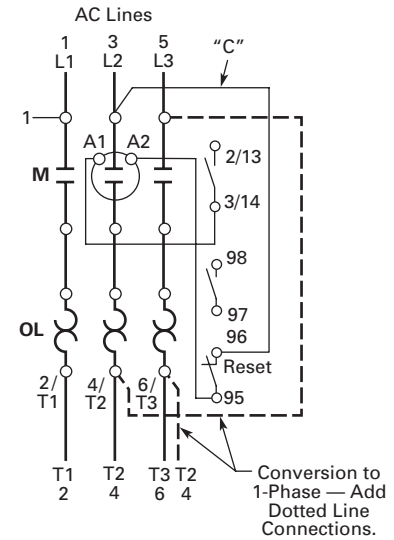

Figure 1-6. Typical Line Diagram