

# Installation instructions for Eaton Innovative Technology Equalizer 2 Series surge protective device (SPD)



## Contents

Description	Page
1. Introduction . . . . .	2
2. Equalizer 2 Series catalog number . . . . .	3
3. Equalizer 2 Series product nameplate . . . . .	3
4. Installation . . . . .	3
5. Wiring diagrams . . . . .	6
6. Operation . . . . .	7
7. Specifications . . . . .	7
8. Maintenance . . . . .	8
9. Liability . . . . .	8
10. Ordering guidelines . . . . .	9
11. Voltage configurations per enclosure size . . . . .	9
12. Warranty . . . . .	10



*Powering Business Worldwide*

## 1. Introduction

### 1.1 Manual introduction

This installation manual describes the installation and operation of the Eaton Innovative Technology Equalizer 2 Series surge protective device (SPD). This technical document covers most aspects of installation and operation. This document is a guide only for licensed/qualified electricians. If you require further information regarding a particular installation, application, or maintenance activity, please contact your Eaton Innovative Technology Master Distributor. These instructions do not cover all details, variations or combinations of the equipment, its storage, delivery, installation, check-out, safe operation or maintenance. Care must be exercised to comply with local, state, and national regulations, as well as safety practices for this class of equipment.

**Please read and understand ALL installation and operating instructions prior to installation and use of this equipment.**

### 1.2 Product overview

The Eaton Innovative Technology Equalizer 2 Series protects critical electrical and electronic equipment from damage by voltage transients and surges when properly installed. This is done by shunting high energy lightning surges (and other transient disturbances) away from the equipment being protected. It does this in nanoseconds by providing a low impedance surge path through thermally protected metal oxide varistors while supporting power frequency voltage. Eaton's Type 2 Equalizer 2 models equipped with EMI Filtering are designed to protect sensitive equipment from electrical noise. Proper installation is critical to ensure the Equalizer 2 operates as intended.

Eaton's Type 1 SPD is intended for installation between the secondary of the service transformer and the line side of the service equipment overcurrent device. As well as the load side, including watt-hour meter socket enclosures and Molded Case surge protective devices intended to be installed without an external overcurrent protective device.

Eaton's Type 2 SPD is intended for installation on the load side of the service equipment overcurrent device. Including branch panel locations and functions to protect sensitive electronic equipment from damaging voltage transients and surges.

Equalizer 2 devices should be installed as close as possible to the equipment to be protected.

The Equalizer 2 Series is available in voltage ratings from 120 Vac to 600 Vac, surge current ratings from 50kA to 200kA, and two sizes of Type 4X enclosures. Enclosure size is determined by voltage and peak surge current rating. The P1 enclosure measures 6.00" x 5.56" x 3.19" (152.3 mm x 141.2 mm x 81.1 mm) with a maximum weight of 2.5 lbs (1.13 kg). The P2 enclosure measures 8.50" x 7.56" x 3.19" (215.9 mm x 192.0 mm x 81.1 mm) with a maximum weight of 4.15 lbs (1.81 kg).

The Equalizer 2 Series is available in eight feature options, see **Section 10, Ordering guidelines** for more details.

### 1.3 Safety precautions

---

#### WARNING

---

**WARNING – SHOCK HAZARD – DO NOT OPEN.**  
**AVERTISSEMENT – RISQUE DE CHOC – NE PAS OUVRIR.**

**WARNING NO SERVICEABLE PARTS.**  
**ATTENTION : AUCUNE PIÈCE REMPLACABLE OU RÉPARABLE.**

**A LICENSED/QUALIFIED ELECTRICIAN MUST COMPLETE ALL INSTRUCTIONS IN THIS MANUAL IN ACCORDANCE WITH THE NATIONAL ELECTRIC CODE (NEC), CANADIAN ELECTRICAL CODE (CEC), STATE, AND LOCAL CODES, OR OTHER APPLICABLE COUNTRY CODES. ALL APPLICABLE LOCAL ELECTRICAL CODES SUPERSEDE THESE INSTRUCTIONS.**

**CHECK THE VOLTAGE-RATING LABEL LOCATED ON THE SIDE OF THE SPD TO VERIFY THAT THE ELECTRICAL SYSTEM'S VOLTAGE AND WIRING CONFIGURATION ARE THE SAME AS THE SPD.**

**CONDUCTING DIELECTRIC, MEGGAR, OR HI-POTENTIAL TESTING WITH THE SPD INSTALLED WILL CAUSE INTERNAL DAMAGE TO THE SPD. THE SPD WILL CAUSE THE TEST TO FAIL.**

**IMPROPER INSTALLATION COULD CAUSE DEATH, INJURY AND EQUIPMENT DAMAGE. FOLLOW ALL WARNINGS AND CAUTIONS. COMPLETELY READ AND UNDERSTAND THE INFORMATION IN THIS INSTRUCTION MANUAL BEFORE ATTEMPTING TO INSTALL OR OPERATE THIS EQUIPMENT.**

**ARC FLASH DURING INSTALLATION COULD CAUSE INJURY OR DEATH. USE APPROPRIATE SAFETY PRECAUTIONS AND EQUIPMENT FOR ARC FLASH PROTECTION.**

**INSTALLING A PROTECTION DEVICE WHICH IS UNDER RATED FOR THE ELECTRICAL SYSTEM VOLTAGE CAN CREATE A POTENTIALLY HAZARDOUS CONDITION.**

**CHECK THE FACILITY'S GROUNDING SYSTEM. ALL GROUNDING, BONDING AND EARTHING PRACTICES MUST MEET NEC, CEC AND LOCAL APPROVED PRACTICES. A POOR GROUND, OR A GROUNDING / BONDING VIOLATION WILL SERIOUSLY AFFECT THE SPD'S ABILITY TO FUNCTION AS SPECIFIED.**

---

## 2. Equalizer 2 Series catalog number

Each Eaton Innovative Technology Equalizer 2 Series unit is identified by a catalog number, see **Table 1**. The number identifies the parameters that make up the unit.

**Table 1. Catalog Numbering System**

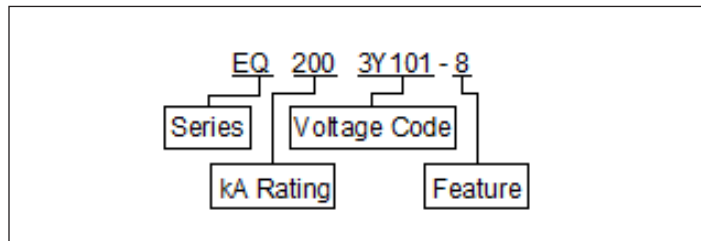

For example, an Equalizer 2 unit with a catalog number of **EQ2003Y101-8**, where:

**EQ** = Equalizer 2 Series

**200** = peak surge current rating (50 kA – 200 kA)

**3Y101** = voltage code and system configuration

**8** = feature option (1 – 8)

See **Section 10. Ordering guidelines** for additional surge current kA ratings, voltage codes and feature options.

## 3. Equalizer 2 Series product nameplate

Each Eaton Innovative Technology Equalizer 2 Series unit has a nameplate affixed to the side of the unit that identifies the catalog number and operating parameters. The catalog # consists of letters and numbers which identify the Equalizer 2 Series, kA rating, voltage code, and feature option as shown in Figure 1.

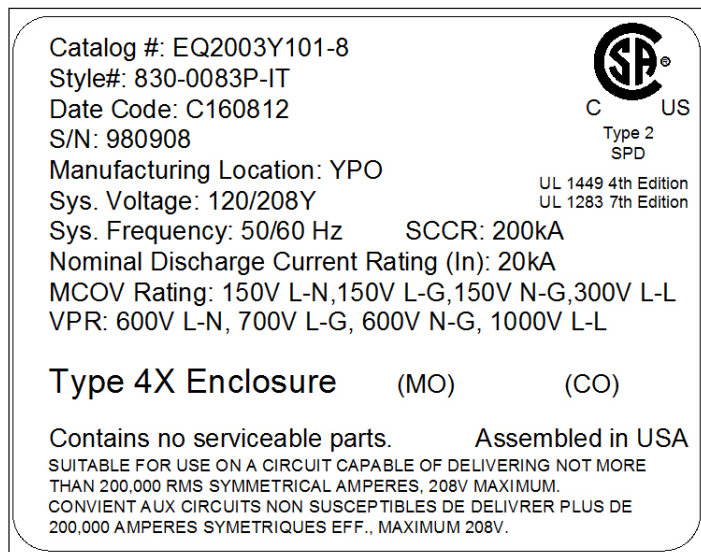

**Figure 1. Equalizer 2 Series Product Nameplate.**

## 4. Installation

### ⚠ WARNING

**A LICENSED/QUALIFIED ELECTRICIAN MUST COMPLETE ALL INSTRUCTIONS IN THIS MANUAL IN ACCORDANCE WITH THE NATIONAL ELECTRIC CODE (NEC), CANADIAN ELECTRICAL CODE (CEC), STATE, AND LOCAL CODES, OR OTHER APPLICABLE COUNTRY CODES. ALL APPLICABLE LOCAL ELECTRICAL CODES SUPERSEDE THESE INSTRUCTIONS.**

**INSTALLING AN SPD THAT IS IMPROPERLY RATED FOR THE ELECTRICAL SYSTEM VOLTAGE COULD CREATE A POTENTIALLY HAZARDOUS CONDITION, RESULTING IN INJURY OR EQUIPMENT DAMAGE.**

**CHECK THE VOLTAGE-RATING LABEL LOCATED ON THE SIDE OF THE SPD TO VERIFY THAT THE ELECTRICAL SYSTEM'S VOLTAGE AND WIRING CONFIGURATION ARE THE SAME AS THE SPD.**

**TO PROVIDE THE BEST PROTECTION FOR SENSITIVE ELECTRICAL EQUIPMENT THE 10 AWG WIRES SHOULD BE LESS THAN 14" IN LENGTH, TWISTED TOGETHER AND THEN BOUNDED.**

**AVOID USING 90° CONDUIT ELBOWS AND KEEP THE CONDUIT RUN AS SHORT AND STRAIGHT AS POSSIBLE. SEE FIGURES 2 AND 3.**

**WHEN MOUNTING THE SPD OUTDOORS, USE WEATHERPROOF CONDUIT AND FITTINGS TO MAINTAIN THE ENCLOSURE'S NEMA TYPE 4X RATING.**

**FOR USE ON CIRCUITS DELIVERING UP TO 5000 RMS AMPS. CONVIENT Á DES CIRCUITS PRODUCISANT AU PLUS 5000 A EFF.**

Before installing an Eaton Equalizer 2 Series unit:

1. Verify that the area is clear of any dirt, debris or clutter that may hamper the installation process.
2. Verify that there is enough space to install the Equalizer 2 device. See Figures 4 & 5 for dimensions.
3. Confirm that the system voltage and wiring configuration is the same as the Equalizer 2 device you are installing. See **Section 5. Wiring Diagrams**.
4. Check the facility grounding system. All grounding, bonding, and earthing must meet the NEC, CEC and any other national, state and local electrical codes.
5. An insulated grounding conductor that is identical in size and insulation material and thickness to the grounded and ungrounded circuit supply conductors, except that it is green with or without one or more yellow stripes, is to be installed as part of the circuit that supplies the Equalizer 2 Series unit.
6. Refer to Table 250-122 of the NEC to select the appropriate size of the grounding conductor. This grounding conductor is to be grounded to earth at the service equipment or other acceptable building earth ground such as the building frame in the case of a high steel-frame structure.

### 4.1 Mounting

### ⚠ IMPORTANT

**ALL CONNECTIONS IN THIS PROCEDURE MUST BE MADE IN ACCORDANCE WITH NEC, CEC, STATE, COUNTY AND LOCAL CODES FOR ALL SAFETY RATINGS.**

**TO ENSURE MAXIMUM EFFECTIVENESS AND PROVIDE THE BEST POSSIBLE PROTECTION FOR SENSITIVE ELECTRICAL EQUIPMENT, MOUNT IN SUCH A WAY AS TO MINIMIZE THE CABLE LENGTH AND ELIMINATE ANY SHARP BENDS IN THE WIRING CONDUIT. SEE FIGURE 2.**

**WHEN USING CONDUIT, AVOID USING 90° ELBOWS AND KEEP THE CONDUIT RUN AS SHORT AND STRAIGHT AS POSSIBLE. SEE FIGURE 3.**

#### 4.2 Panel mounted

The preferred mounting of the Equalizer 2 is directly to the electrical panel with its integrated male connector hub and the supplied 3/4" trade size conduit locknut. Insert the wires through the panel wall being careful not to damage the wire insulation. Install the provided locknut and tighten to 20.3 lb-in (2.3 N-m). If mounting requires the NEMA 4X rating, install the supplied mounting feet to the enclosure and securely mount the unit using #8 flat head screws (not included). Be sure to use the appropriate gasket/liquid-tight fitting (not included) between the unit and the panel wall. Liquid-tight conduit torque should not exceed 200 lb-in (22.5 N-m).

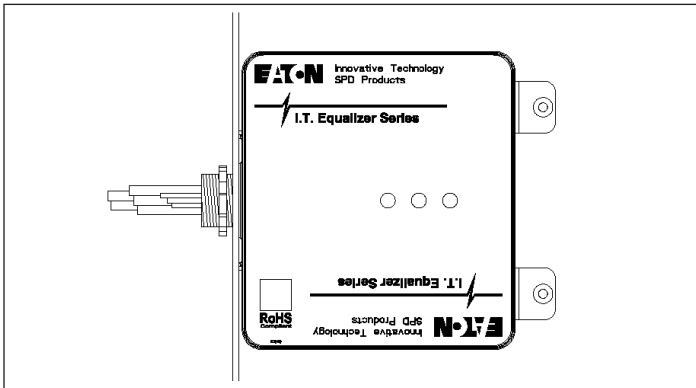

Figure 2. Preferred Installation.

#### 4.3 Panel mounted with conduit

In situations where the above preferred direct mounting cannot be employed optional conduit mounting can be utilized. In this case mount the Equalizer 2 as close as possible to the electrical panel using 3/4" trade size conduit, 3/4" trade size coupling, 3/4" trade size connector and the supplied 3/4" trade size conduit locknut.

**Note:** to maximize the Equalizer 2's performance, 10 AWG wire length should be less than 14" (35 cm) twisted and bound together.

Attach the conduit coupling, conduit and connector. Then insert the wires through the conduit and through the panel wall being careful not to damage the wire insulation. Install the provided locknut and tighten to 20.3 lb-in (2.3 N-m). If mounting requires the NEMA 4X rating, install the provided four mounting feet to the enclosure and be sure to use the appropriate gasket/liquid-tight fittings (not included) between the unit and the panel wall. Liquid-tight conduit torque should not exceed 200 lb-in (22.5 N-m).

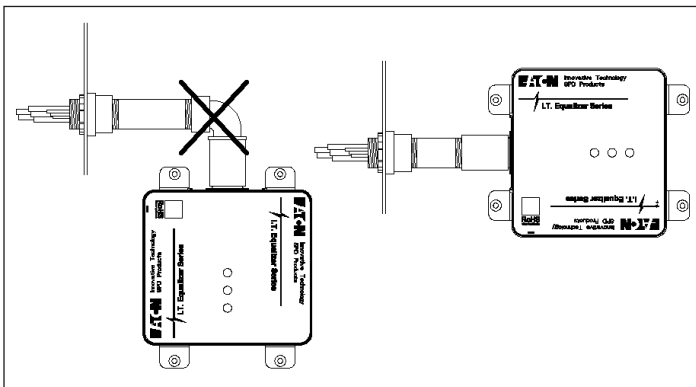

Figure 3. Alternate Installation.

When mounting the Equalizer 2 outdoors, use the supplied mounting feet, weatherproof conduit and fittings to maintain the enclosure's Type 4X rating.

#### 4.4 Enclosure mounting feet

The mounting feet attach to the bottom of the enclosure with the provided screws (hardware to mount the feet to wall are not included). See **Figure 4 and 5**.

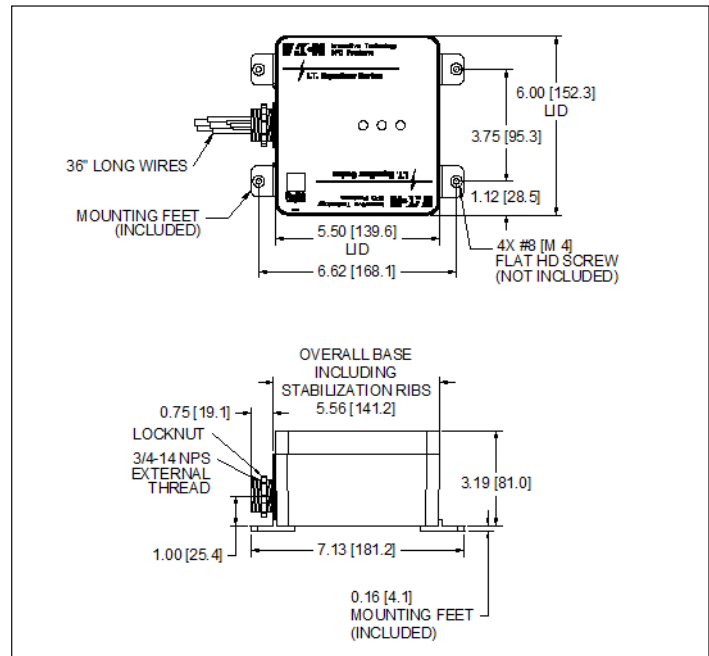

Figure 4. P1 Enclosure w/Mounting Feet Dimensions.

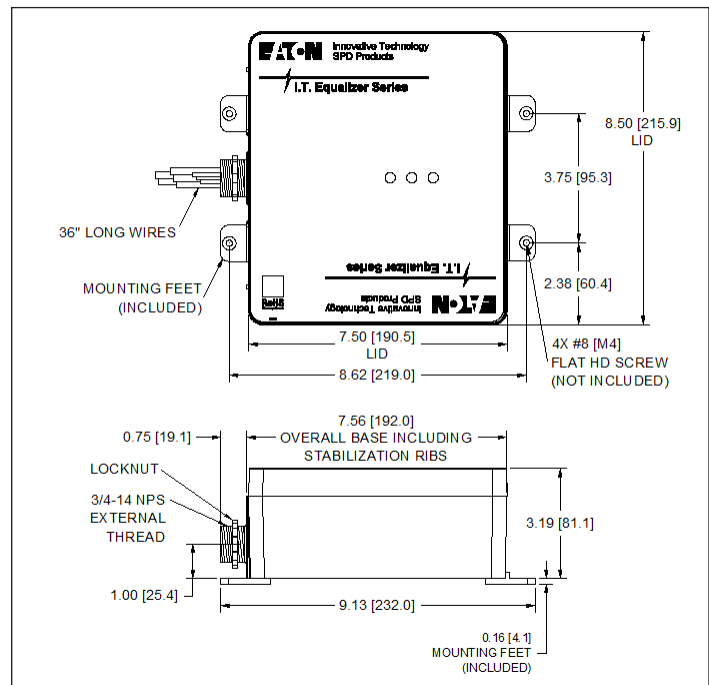

Figure 5. P2 Enclosure w/Mounting Feet Dimensions.

#### 4.5 Optional flush mount plate

Optional Flush Mount Plates are available for both the P1 and P2 enclosure sizes. See **Figures 6 & 7**.

**Catalog# FLUSHMNTPLATE13-IT** – P1 Enclosure Flush Mount Plate

**Catalog# FLUSHMNTPLATE14-IT** – P2 Enclosure Flush Mount Plate

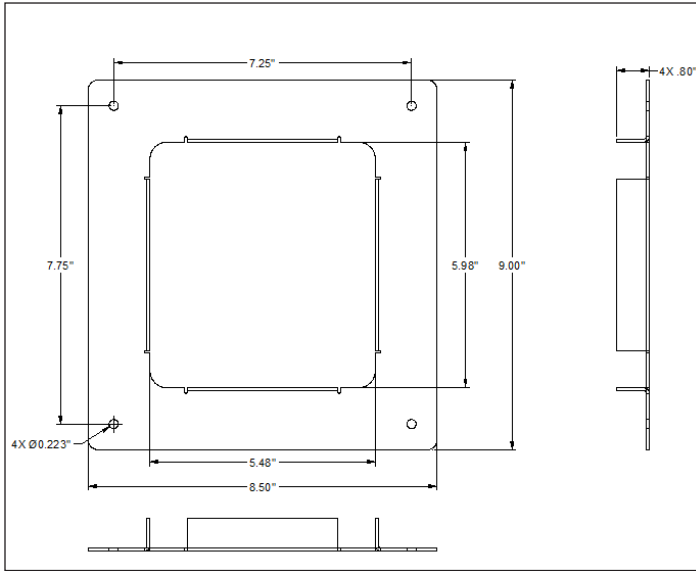

**Figure 6. Optional P1 Enclosure Flush Mount Plate. Catalog# FLUSHMNTPLATE13-IT.**

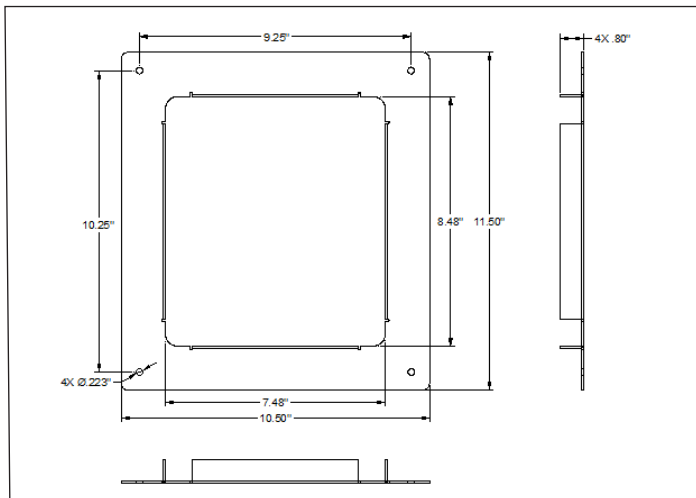

**Figure 7. Optional P2 Enclosure Flush Mount Plate. Catalog# FLUSHMNTPLATE14-IT**

#### 4.6 Wiring installation

### **⚠ WARNING**

**IMPROPER WIRING COULD CAUSE DEATH, INJURY AND/OR EQUIPMENT DAMAGE. ONLY LICENSED/QUALIFIED ELECTRICIANS WHO ARE TRAINED IN THE INSTALLATION AND SERVICE OF ELECTRICAL SERVICES ARE TO INSTALL AND SERVICE THIS EQUIPMENT.**

**TO MAXIMIZE THE SPD'S PERFORMANCE, TWIST AND BIND THE WIRES TOGETHER TO REDUCE THE IMPEDANCE OF THE WIRE.**

**ARC FLASH DURING INSTALLATION COULD CAUSE INJURY OR DEATH. USE APPROPRIATE SAFETY PRECAUTIONS AND EQUIPMENT FOR ARC FLASH PROTECTION.**

Locate the electrical system's applicable wiring schematic in **Section 5 Wiring Diagrams**.

**Turn OFF** power to the electrical equipment being connected to the **Equalizer 2 in accordance with NEC, CEC, state, county and local codes for all safety ratings.**

Eaton Innovative Technology Equalizer 2 devices covered in this guide are designed with internal overcurrent protection and do not require an external overcurrent protection device (OCPD) unless otherwise required by NEC, UL, and local electrical requirements to protect electrical conductors. NEC Article 310.15 (B) (16) defines the maximum rating of the OCPD required to protect the electrical conductors.

NEC shows #10 AWG conductors at 60°C typically requiring a 1-pole (for single phase systems), 2-pole (for split-phase systems) or 3 pole (for 3-phase systems) 30A branch circuit breaker to protect the conductors.

Twist and bind the wires of the Equalizer 2 unit tightly together. Minimize overall lead length to optimize Equalizer 2 performance. For wire lengths longer than four inches, phase wires should be twisted once for each four inches of wire length to maximize performance.

**Note:** to maximize the Equalizer 2's performance, 10 AWG wire length should be less than 14" (35cm) twisted and bound together.

If remote monitoring is required, connect the Form C relay contact wiring to an alarm or building monitoring system. These relay contacts are rated:

2A at 30Vdc or 250Vac

Refer to **Table 2 – Equalizer 2 Series Form C Wire Color Codes for color codes** of relay wires (shown in the energized state).

**Note:** Utilization of Form C contacts is optional. Connection of Form C wires is not required for the proper operation of the Equalizer 2.

Tighten and recheck all connections and mounting.

**Table 2. Equalizer 2 Series Form C Wire Color Code**

FORM C WIRE COLOR CODE	
CONTACT	COLOR
COM	BLUE/WHITE
NO	RED/WHITE
NC	ORANGE/WHITE

## 5. Wiring diagrams

**Table 3. Equalizer 2 Series Phase Wire Color Code**  
**PHASE WIRE COLOR CODE**

PHASE WIRE	COLOR
L1 (Phase A)	Black
L2 (Phase B)	Black
L2 (Phase B) High Leg Delta	Orange
L3 (Phase C)	Black
Neutral	White
Ground / Protected Earth	Green w/ Yellow Stripe

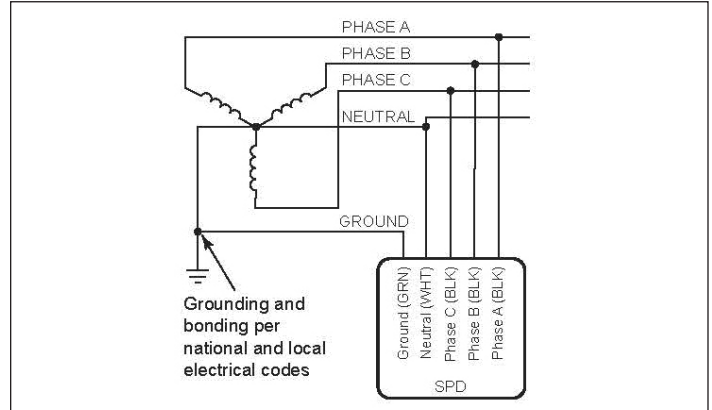

**Figure 11. Three Phase Wye (4W+G).**

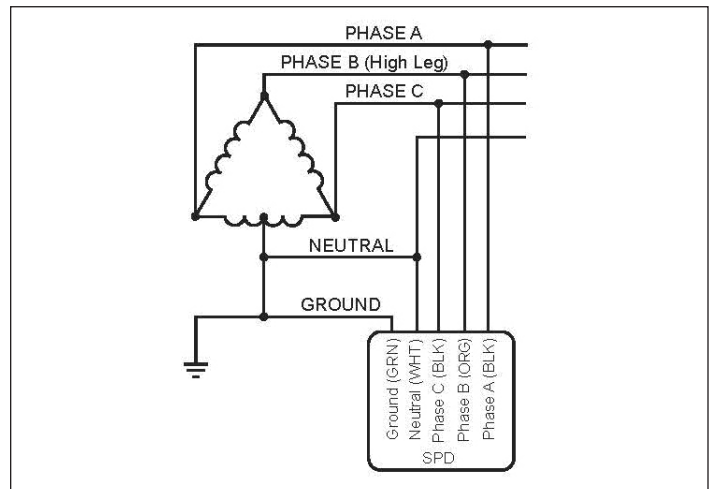

**Figure 12. Three Phase High Leg Delta on Phase B (4W+G).**

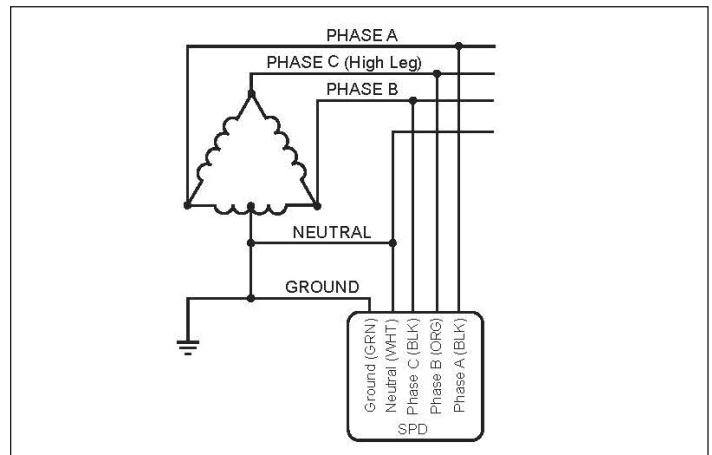

**Figure 13. Three Phase High Leg Delta on Phase C (4W+G).**

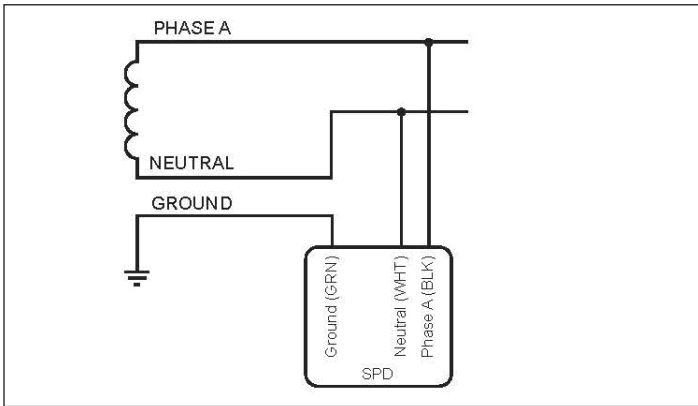

**Figure 8. Single Phase (2W+G).**

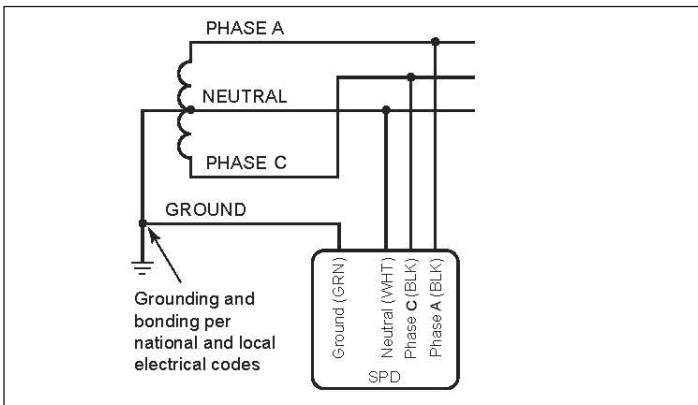

**Figure 9. Split Phase (3W+G).**

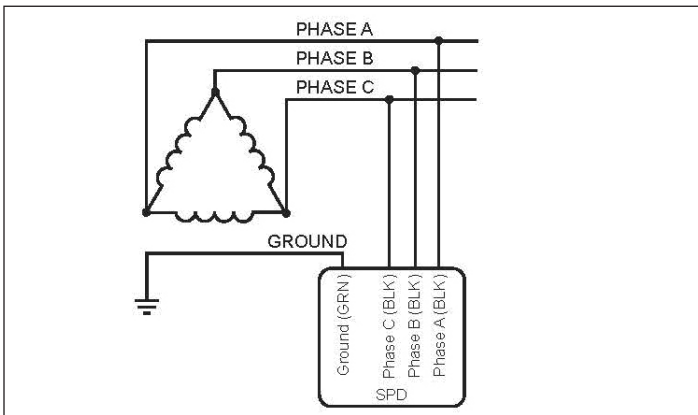

**Figure 10. Three Phase Delta (3W+G).**



## 6. Operation

### 6.1 Power up and system checkout

Switch main panel power to ON and then switch Equalizer 2's branch circuit breaker to ON. One LED should light for each phase voltage being monitored. Single phase electrical systems will light only one LED, split phase systems light two LEDs, and three phase systems will light all three LEDs.

If the connected LEDs do not light, remove power, check connections, and test again. If the LEDs still do not light, contact your Eaton Innovative Technology Master Distributor or Eaton's Technical Resource Center at: 1-800-647-8877, or email [spd@eaton.com](mailto:spd@eaton.com) as the Equalizer 2 may be damaged.

### 6.2 LED color states

The LED's located on the lid of the Equalizer 2 has three LED color states,

**Green – fully protected**

**Yellow – loss of Neutral to Ground protection**

**Red – loss of phase protection**

If the electrical system is single, split or 3 phase, the Equalizer 2 will have either one, two or three green illuminated LEDs, respectively. Each LED will illuminate when its associated phase voltage is present.

If any of these LEDs are yellow or red a problem may exist with incoming power, wiring, branch circuit breaker wiring or within the Equalizer 2 itself. Disconnect power, check connections and test again. If the LEDs are still yellow or red, disconnect power to the Equalizer 2 and contact your Eaton Innovative Technology Master Distributor or Eaton's Technical Resource Center at: 1-800-647-8877, or email [spd@eaton.com](mailto:spd@eaton.com) as the Equalizer 2 may be damaged.

### 6.3 Options: audible alarm and form C relay

**Note:** Utilization of Form C contacts is optional. Connection is not required for the proper operation of the Equalizer 2.

The audible alarm and Form C relay are tied to the Phase LED's located on the Equalizer 2 Series enclosure's lid. If protection to one or more phases is lost the following will occur:

- Single, Split and 3 Phase devices - if all voltage is lost to the Equalizer 2 then the green LED(s) will go out, the alarm will not sound and the relay will not be energized.
- Split and 3 Phase devices - if one phase voltage is lost to the Equalizer 2 then that one green LED will go out, the alarm will not sound and the relay will stay energized (if there is another phase voltage present).
- 3 Phase Wye and 3 Phase High Leg Delta devices - if one or two phase voltages are lost to the Equalizer 2 then one or two green LEDs will go out, the alarm will not sound and the relay will stay energized (if there is another phase voltage present).
- 3 Phase Delta – Equalizer 2 needs at least 2 phases to energize the relay and to keep the alarm from sounding (if installed).
- Single, Split and 3 Phase devices - if one or more LEDs turn red, the alarm will sound and the relay will de-energize. **To silence the alarm, disconnect power to the Equalizer 2** and contact your Eaton Innovative Technology Master Distributor or Eaton's Technical Resource Center at: 1-800-647-8877, or email [spd@eaton.com](mailto:spd@eaton.com) as the Equalizer 2 may be damaged.

**Note:** Form C relay contacts are "fail safe" and only change state when power is applied to the Equalizer 2 and the electrical system is operating normally or when loss of protection is detected and yellow or red LEDs are illuminated.

## 7. Specifications

kA per Phase	50, 80, 100, 120, 150, 160, 200
Nominal Discharge Current	20kA
Single Phase Voltages	120, 240, 277, 480
Split Phase Voltages	120/240
Wye System Voltages	120/208, 240/415, 277/480, 347/600
Delta System Voltages	240, 480, 600
High Leg Delta Voltage	240
Input Power Frequency	50/60 Hz
Protection Modes	Single Phase L-N, N-G, L-G Split Phase L-N, N-G, L-G, L-L Wye L-N, N-G, L-G, L-L Delta L-G, L-L High Leg L-N,N-G,L-G,L-L,H-N,H-G,H-L
Mounting feet Torque rating	20.3 lb-in (2.3 N-m)
Conduit locknut Torque rating	Not to exceed 200 lb-in (22.5 N-m)
Operating Temperature	-40°F to +140°F (-40°C to +60°C)
Relative Humidity	5% - 95%, non condensing
Max. altitude	2000 m
Weight, vary per configuration	P1 enclosure ~2.5 lbs P2 enclosure ~4.0 lbs
Certification/Listing	UL 1449 4th edition, UL1283 7th edition, CSA 269.1-14, 269.2-15, C22.2 No. 8-13 EMI Filter
SPD Type	UL1449 4th edition & CSA Type 1 and Type 2 SPD
RoHS Compliant	Yes
Enclosure Rating	Type 4X Enclosure w/ mounting feet, IP56
Wire Length and AWG	Factory prewired with 36 inches of 10 AWG wire

## 8. Maintenance

The Equalizer 2 is a self-contained device that requires no maintenance and contains no serviceable parts. If any LED turns red or yellow the unit has lost surge protection and must be replaced. Please contact your Eaton Innovative Technology Master Distributor or Eaton's Technical Resource Center at: 1-800-647-8877, or email [spd@eaton.com](mailto:spd@eaton.com) for additional information and technical assistance, as the Equalizer 2 may be under warranty.

## 9. Liability

This instruction booklet is published solely for information purposes and should not be considered all-inclusive. If further information is required, you should consult Eaton's Technical Resource Center at: 1-800-647-8877 or email [spd@eaton.com](mailto:spd@eaton.com). Sale of the product shown in this literature is subject to terms and conditions outlined in appropriate Eaton selling policies or other contractual agreements between the parties. This literature is not intended to and does not enlarge or add to any such contract. The sole source governing the rights and remedies of any purchaser of this equipment is the contract between the purchaser and Eaton.

**NO WARRANTIES, EXPRESSED OR IMPLIED, INCLUDING WARRANTIES OF FITNESS FOR A PARTICULAR PURPOSE OR MERCHANTABILITY, OR WARRANTIES ARISING FROM COURSE OF DEALING OR USAGE OF TRADE, ARE MADE REGARDING THE INFORMATION, RECOMMENDATIONS AND DESCRIPTIONS CONTAINED HEREIN.**

In no event will Eaton be responsible to the purchaser or user in contract, in tort (including negligence), strict liability or otherwise for any special, indirect, incidental or consequential damage or loss whatsoever, including but not limited to damage or loss of equipment use, plant or power system, cost of capital, loss of power, additional expenses in the use of existing power facilities or claims against the purchaser or user by its customers resulting from the use of the information, recommendations and description contained herein.



## 10. Ordering guidelines

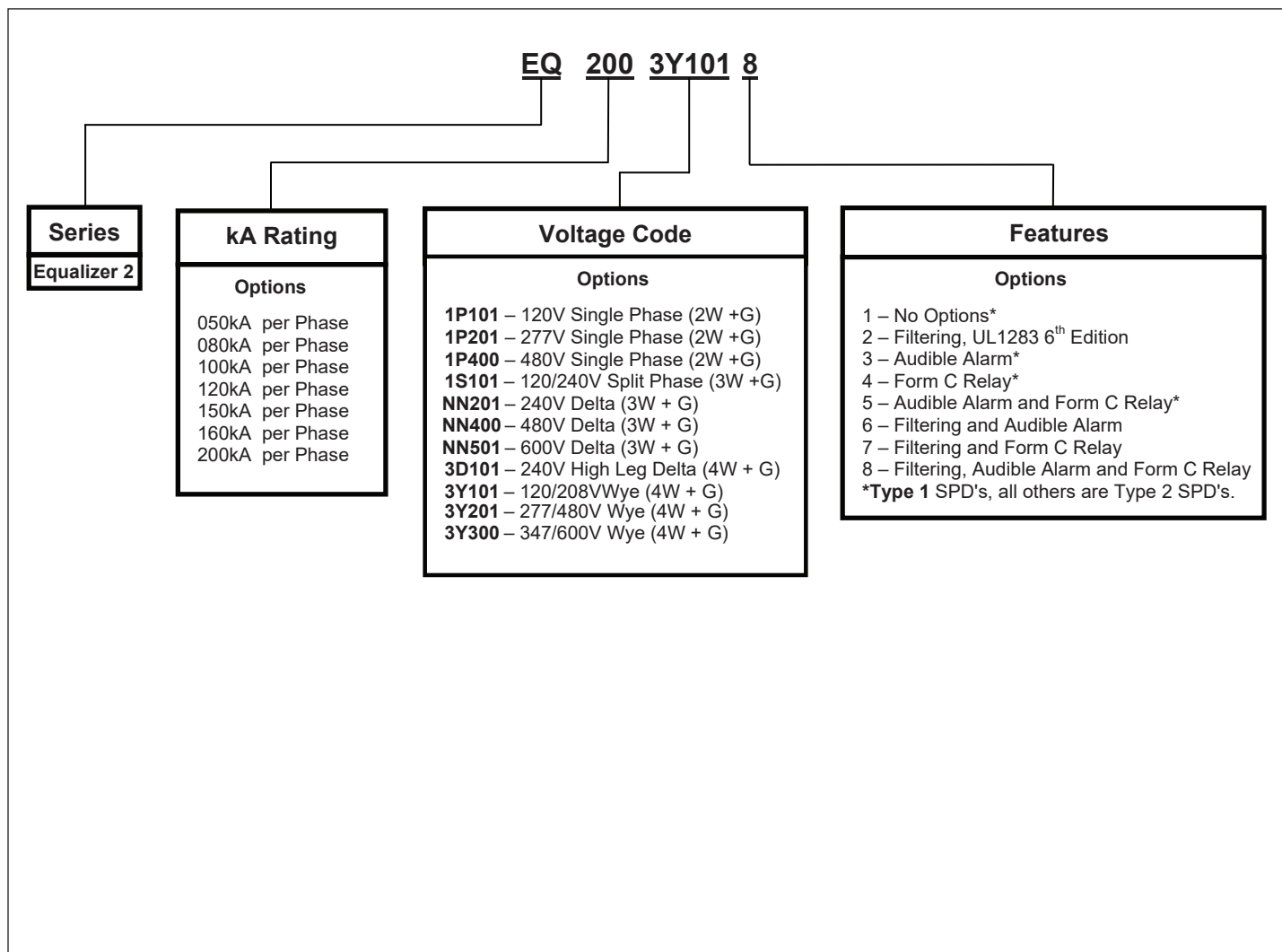

Figure 14. Ordering Guidelines

## 11. Voltage configurations per enclosure size

P1 Enclosure		P2 Enclosure	
1P101/1P201/1P400	50kA – 200kA	NN501	50kA – 200kA
1S101	50kA – 100kA	1S101	120kA – 200kA
3Y101/3Y201/3Y300	50kA – 100kA	3Y101/3Y201/3Y300	120kA – 200kA
NN201/NN400	50kA – 100kA	NN201/NN400	120kA – 200kA
3D101	50kA – 100kA	3D101	120kA – 200kA

## 12. Warranty

Eaton warrants the Equalizer 2 to be free from defects in both workmanship and materials for a period of five years, ten years if the product is properly registered, from the date of delivery to the purchaser. To register, go to [www.eaton.com/itvss](http://www.eaton.com/itvss) and click on the warranty registration icon.

Eaton assumes no risk or liability for results of the use of the product purchased, including but not limiting the generality of the foregoing:

(1) The use in combination with any electrical or electronic components, circuits, systems, assemblies or any other materials or substances.

(2) Unsuitability of any product for use in any circuit or assembly.

Purchaser's rights under the warranty shall consist solely of requiring Eaton to repair, or at Eaton's sole discretion, replace, free of charge, F.O.B. factory, any defective items received at said factory within said term determined by Eaton to be defective. The giving of or failure to give any advice or recommendations by Eaton shall not constitute any warranty by or impose any liability upon Eaton AND IS IN LIEU OF ANY AND ALL OTHER WARRANTIES EXPRESSED, IMPLIED OR STATUTORY AS TO THE MERCHANTABILITY, FITNESS FOR PURPOSE SOLD, PRODUCTIVENESS OR ANY OTHER MATTER. In no event shall Eaton be liable for special or consequential damages or for delay in performance of the warranty.

This warranty does not apply if the unit has been misused, abused, altered, tampered with, or applied in excess of the specifications other than those written on the nameplate. At the end of the warranty period Eaton shall be under no further warranty obligation expressed or implied.

The Eaton Innovative Technology Equalizer 2 covered by this warranty certificate can only be repaired or replaced by the factory. A RETURN MATERIAL AUTHORIZATION (RMA) number must be obtained. Please enter a Vista warranty claim by contacting your Eaton Innovative Technology Master Distributor or the Eaton Technical Resource Center at 1-800-647-8877, or email [spd@eaton.com](mailto:spd@eaton.com) for help entering a claim or to obtain an update on your claim status. Repair or replacement will be returned collect. If it is determined that the returned product contains manufacturer's defects then Eaton will replace the defective product at Eaton's expense (including shipping charge).

**Notes:**

For additional information please call:  
All Rights Reserved  
Eaton's Technical Resource Center  
Publication No. IB158009EN  
1-800-647-8877  
or email [spd@eaton.com](mailto:spd@eaton.com)

**Notice:**

Product improvements and enhancements are continuous; therefore the specifications and information contained in this document may change without notice.

Eaton shall not be liable for errors contained herein or for incidental or consequential damages in connection with the furnishing, performance, or use of this material.

No part of this document may be reproduced for publication, or translated to another language without the prior written consent of Eaton.

Copyright © 2016, Eaton, All Rights Reserved



**Eaton**  
1000 Eaton Boulevard  
Cleveland, OH 44122  
United States  
[Eaton.com](http://Eaton.com)

© 2018 Eaton  
All Rights Reserved  
Printed in USA  
Publication No. IB158009EN / TBG001343  
October 2018