

Circuit Breakers

Circuit Breaker Curves

The following curve illustrates a typical thermal magnetic molded case circuit breaker curve with an overload region and an instantaneous trip region (two instantaneous trip settings are shown). Circuit breaker time-current characteristic curves are read similar to fuse curves. The horizontal axis represents the current, and the vertical axis represents the time at which the breaker interrupts the circuit.

When using molded case circuit breakers of this type, there are four basic curve considerations that must be understood. These are:

1. Overload Region
2. Instantaneous Region
3. Unlatching Time
4. Interrupting Rating

1. Overload Region: The opening of a molded case circuit breaker in the overload region is generally accomplished by a thermal element, while a magnetic coil is generally used on power breakers. Electronic sensing breakers will utilize CTs. As can be seen, the overload region has a wide tolerance band, which means the breaker should open within that area for a particular overload current.

2. Instantaneous Region: The instantaneous trip (I.T.) setting indicates the multiple of the full load rating at which the circuit breaker will open as quickly as possible. The instantaneous region is represented in the following curve and is shown to be adjustable from 5x to 10x the breaker rating. When the breaker coil senses an overcurrent in the instantaneous region, it releases the latch which holds the contacts closed.

The unlatching time is represented by the curve labeled “average unlatching time for instantaneous tripping.” After unlatching, the overcurrent is not halted until the breaker contacts are mechanically separated and the arc is extinguished. Consequently, the final overcurrent termination can vary over a wide range of time, as is indicated by the wide band between the unlatching time curve and the maximum interrupting time curve.

The instantaneous trip setting for larger molded case and power breakers can usually be adjusted by an external dial. Two instantaneous trip settings for a 400A breaker are shown. The instantaneous trip region, drawn with the solid line, represents an I.T. = 5x, or five times 400A = 2000A. At this setting, the circuit breaker will trip instantaneously on currents of approximately 2000A or more. The $\pm 25\%$ band represents the area in which it is uncertain whether the overload trip or the instantaneous trip will operate to clear the overcurrent.

The dashed portion represents the same 400A breaker with an I.T. = 10x, or 10 times 400A = 4000A. At this setting the overload trip will operate up to approximately 4000 amps ($\pm 10\%$). Overcurrents greater than 4000A ($\pm 10\%$) would be cleared by the instantaneous trip.

The I.T. of a circuit breaker is typically set at its lowest setting when shipped from the factory.

3. Unlatching Times: As explained above, the unlatching time indicates the point at which the breaker senses an overcurrent in the instantaneous region and releases the latch holding the contacts. However, the fault current continues to flow through the breaker and the circuit to the point of fault until the contacts can physically separate and extinguish the arc. Once the unlatching mechanism has sensed an overcurrent and unlatched, the circuit breaker will open. The final interruption of the current represented on the breaker curve in the instantaneous region after unlatching, but within the maximum interruption time.

The relatively long time between unlatching and the actual interruption of the overcurrent in the instantaneous region is the primary reason that molded case breakers are very difficult to coordinate. This is an inherent problem since the breaking of current is accomplished by mechanical means.

4. Interrupting Rating: The interrupting rating of a circuit breaker is a critical factor concerning protection and safety. The interrupting rating of a circuit breaker is the maximum fault current the breaker has been tested to interrupt in accordance with testing laboratory standards. Fault currents in excess of the interrupting rating can result in destruction of the breaker and equipment and possible injury to personnel. In other words, when the fault level exceeds the circuit breaker interrupting rating, the circuit breaker is no longer a protective device.

In the example graph below, the interrupting rating at 480 volts is 30,000 amps. The interrupting ratings on circuit breakers vary according to breaker type and voltage level. The marked interrupting on a circuit breaker is a three-pole rating and NOT a single-pole rating (refer to pages 29 to 34 for more information).

When drawing circuit breaker time-current curves, determine the proper interrupting rating from the manufacturer’s literature and represent this interrupting rating on the drawing by a vertical line at the right end of the curve.

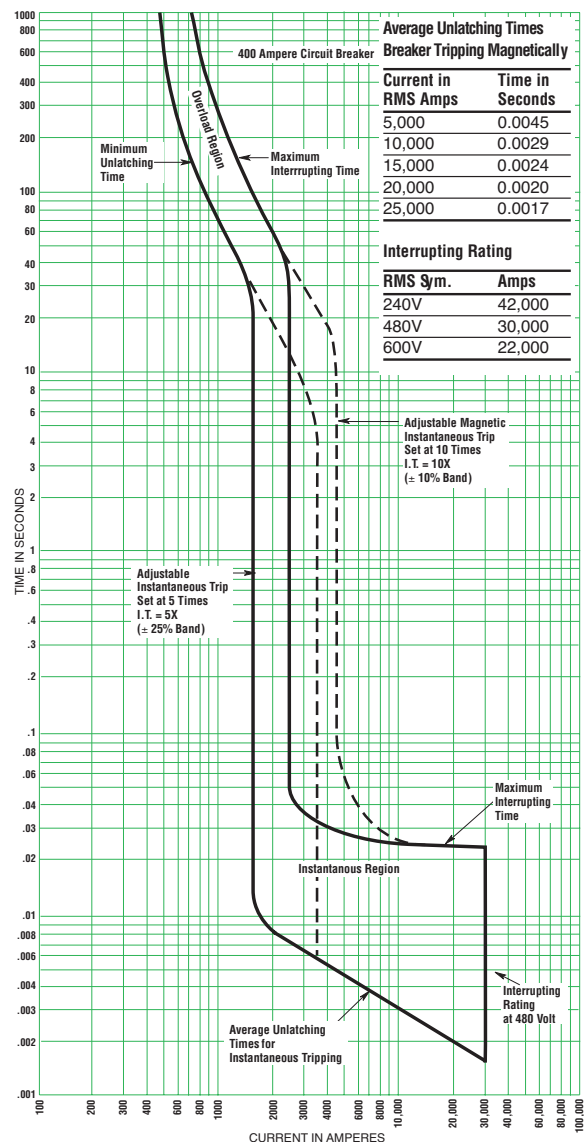

Selective Coordination

Circuit Breakers

Medium to High Level Fault Currents—Circuit Breakers

The following curve illustrates a 400A circuit breaker ahead of a 90A breaker. Any fault above 1500A on the load side of the 90A breaker will open both breakers. The 90A breaker will generally unlatch before the 400A breaker. However, before the 90A breaker can separate its contacts and clear the fault current, the 400A breaker has unlatched and also will open.

Assume a 4000A short circuit exists on the load side of the 90A circuit breaker. The sequence of events would be as follows:

1. The 90A breaker will unlatch (Point A) and free the breaker mechanism to start the actual opening process.
2. The 400A breaker will unlatch (Point B) and it, too, would begin the opening process. Once a breaker unlatches, it will open. At the unlatching point, the process is irreversible.
3. At Point C, the 90A breaker will have completely interrupted the fault current.
4. At Point D, the 400A breaker also will have completely opened the circuit.

Consequently, this is a **non-selective** system, causing a complete blackout to the other loads protected by the 400A breaker.

As printed by one circuit breaker manufacturer, "One should not overlook the fact that when a high fault current occurs on a circuit having several circuit breakers in series, the instantaneous trip on all breakers may operate. Therefore, in cases where several breakers are in series, the larger upstream breaker may start to unlatch before the smaller downstream breaker has cleared the fault. This means that for faults in this range, a main breaker may open when it would be desirable for only the feeder breaker to open." This is typically referred to in the industry as a "cascading effect."

Typically circuit breaker manufacturers do not publish the unlatching times or unlatching curves for their products.

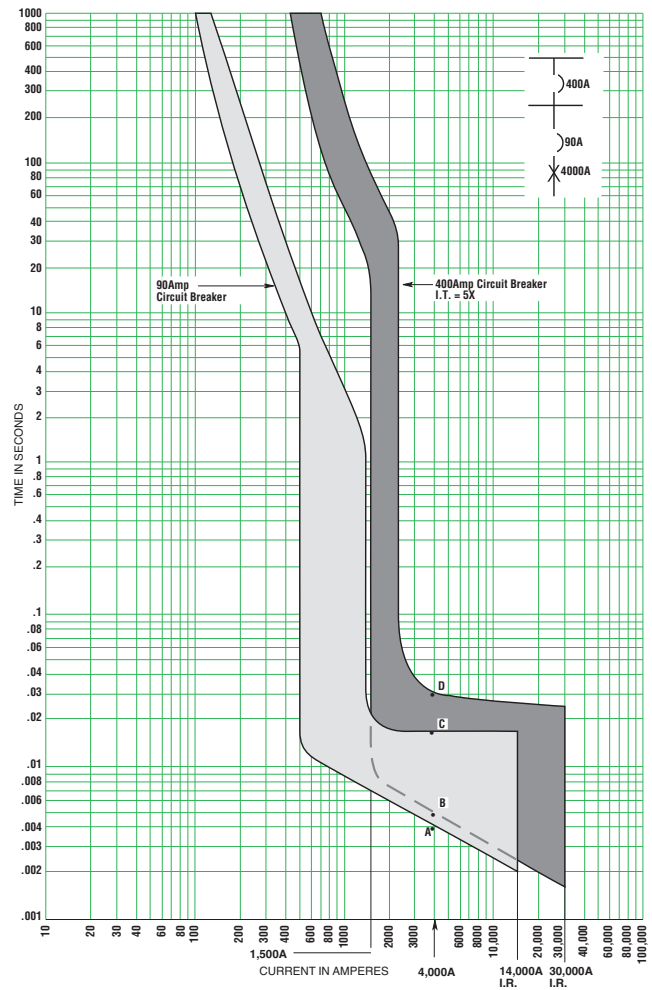

Circuit Breakers

Simple Method To Check Circuit Breaker Coordination

The previous discussion and curve illustrated two molded case circuit breakers (90A and 400A) with the unlatching characteristics for both shown on one curve. This illustrated that two circuit breakers with instantaneous trips can not be selectively coordinated for fault currents above a certain level. That level is the fault current at which the upstream circuit breaker operates in its instantaneous trip region. When a fault above that level occurs, the lower circuit breaker (90A in this case) unlatches. However, before it clears the circuit, the upstream circuit breaker(s) (400A in this case) also unlatches. Once a circuit breaker unlatches, it will open, thereby disconnecting the circuit from the power source. In the case shown, the curves show the 400A circuit breaker needlessly opens for a fault on the load side of the 90A circuit breaker. For any fault current greater than where the two circuit breaker curves intersect (in this case 1500A) the upstream circuit breaker does not coordinate with the down stream circuit breaker.

However, in most cases, manufacturers do not publish unlatching times or unlatching curves for their circuit breakers. Therefore, even the most detailed coordination study from a software program will NOT show whether or not a circuit breaker system is "selectively coordinated." So then, how can coordination of circuit breakers be assessed when all the circuit breakers used in a system have instantaneous trip settings? There is a very simple method that does not even require drawing the circuit breaker time current curves. This method can be used to analyze software program coordination plots in most cases. The following paragraphs present this method.

1. This simple method will be shown **with** the time current curves (but without the unlatching time curves included).
2. However, normally it is not even necessary to draw the time current curves in order to evaluate coordination of circuit breakers having instantaneous trip units. So another section provides this simplified method **without** needing a time current curve.

Below is the one line diagram that will be used for learning these simple methods. Review the one-line diagram below that has three molded case circuit breakers in series: from the main 1200A to the 100A branch circuit with the 400A feeder in between. The other circuit breakers on the one-line diagram supply other circuits and loads. The fault current path from the power source is depicted by the red arrows/lines superseded on the one-line diagram.

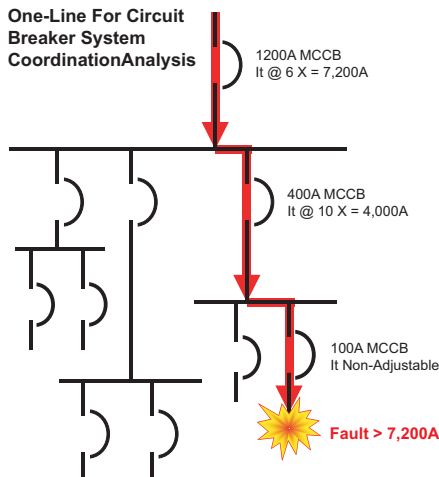

Circuit Breaker Coordination — Simplified Method With Time Current Curve

With the simplified method, there is no need to have the unlatching times or draw the unlatching curves. The following curve illustrates the time current characteristics for the 1200A circuit breaker, the 400A circuit breaker and 100A circuit breaker. The instantaneous trip settings for each of these three molded case circuit breakers are provided on the one-line diagram. The 100A circuit breaker has a non-adjustable instantaneous trip setting and the curve is as depicted. The 400A circuit breaker has an instantaneous trip set at 10 times its amp rating (10X) which is 10 times 400A or 4000A. The 1200A circuit breaker has an instantaneous trip set at six times its amp rating (6X) which is six times 1200A rating or 7200A. Remember from a previous section "2. Instantaneous Region" that there is a tolerance associated with the instantaneous trip region for adjustable instantaneous trip settings; the curve shown for the 400A and 1200A circuit breakers are drawn with the tolerances included.

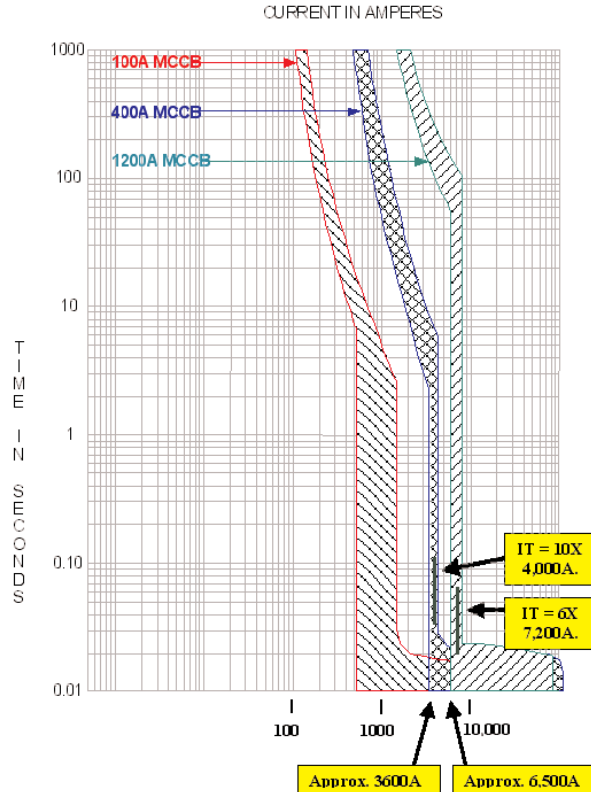

When the curves of two circuit breakers cross over in their instantaneous trip region, then the drawing indicates that the two circuit breakers do not coordinate for fault currents greater than this cross over point.

For instance, interpreting the coordination curves for the 100A circuit breaker and the 400A circuit breaker: their curves intersect in the instantaneous region starting at approximately 3600A. That means for a fault current greater than 3600A on the load side of the 100A circuit breaker, the 400A circuit breaker will open as well as the 100A circuit breaker. This demonstrates a lack of coordination and results in a "cascading effect" that will cause a partial blackout.

This curve also shows that for any fault greater than approximately 6500 amps on the load side of the 100A circuit breaker, the 400A and 1200A circuit breakers will open as well as the 100A circuit breaker. The reason: for a fault of greater than 6500A, all three of these circuit breakers are in their instantaneous trip region. Both the 400A and 1200A circuit breakers can

Selective Coordination

Circuit Breakers

unlatch before the 100A circuit breaker clears the fault current. If this is not understood, re-read the previous section "Circuit Breaker Coordination - Medium to High Level Fault Currents."

How does this affect the electrical system? Look at the one-line diagram below. For any fault current greater than approximately 6500A on the load side of the 100A circuit breaker, the 1200A and 400A circuit breakers open as well as the 100A circuit breaker. The yellow shading indicates that all three circuit breakers opened - 100A branch circuit, 400A feeder and the 1200A main. In addition, all the loads fed by the other circuit breakers, denoted by the hash shading, are blacked out unnecessarily. This is due to the lack of coordination between the 100A, 400A and 1200A circuit breakers.

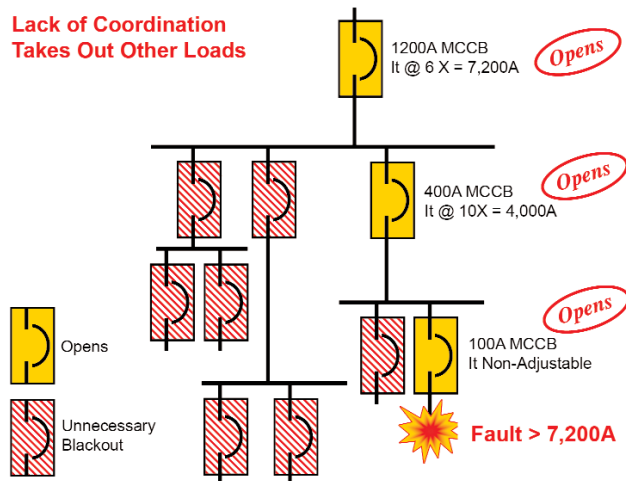

Circuit Breaker Coordination — Simplified Method Without Time Current Curve

It is not even necessary to draw the curves to assess circuit breaker coordination. All that is necessary is to use some simple multiplication. Multiply the instantaneous trip setting times the circuit breaker amp rating (the instantaneous trip setting is usually adjustable but can vary depending upon frame size and circuit breaker type - some have adjustable settings of four to 10 times the amp rating - check specifications of specific circuit breaker). The product of these two is the approximate point at which a circuit breaker enters its instantaneous trip region. (As explained in a previous section "2. Instantaneous Region", there is a tolerance associated with where the instantaneous trip initially picks up. A vertical band depicts the instantaneous trip pickup tolerance. For this easy method, we will ignore the tolerance band; therefore the results differ somewhat from the time current curve example just given.)

For instance, the 400A circuit breaker in this example has its instantaneous trip (IT) set at 10 times its amp rating (10X). Therefore for fault currents above 10 x 400A or 4000A, the 400A circuit breaker will unlatch in its instantaneous trip region, thereby opening.

The same could be determined for the 1200A circuit breaker, which has its instantaneous trip set at 6X its amp rating. Therefore, for fault currents above 7200A, the 1200A circuit breaker unlatches in its instantaneous trip region, thereby opening.

The coordination analysis of the circuit breakers merely requires knowing what the numbers mean:

1. Any fault on the loadside of the 100A circuit breaker greater than 4000A will open the 400A circuit breaker as well as the 100A circuit breaker. Reason: the 400A circuit breaker with an instantaneous trip set at 10 times opens instantaneously for any fault current greater than 4000A.
2. Any fault on the loadside of the 100A circuit breaker greater than 7200A will open the 1200A circuit breaker as well as the 100A and 400A circuit breakers. Reason: the 1200A circuit breaker with an instantaneous trip set at six times opens instantaneously for any fault current greater than 7200A.
3. Any fault on the loadside of the 400A circuit breaker greater than 7200A will open the 1200A circuit breaker as well as the 400A circuit breaker. Reason: the 1200A circuit breaker with an instantaneous trip set at six times opens instantaneously for any fault current greater than 7200A.

So it becomes apparent, to evaluate coordination of circuit breakers with instantaneous trips, the time current curves do not have to be drawn. All that is necessary is to use simple multiplication of the instantaneous trip settings times the circuit breaker amp ratings, and evaluate this in conjunction with the available fault current.

Note: Circuit breakers that provide the use of a short time delay do not always assure coordination. The reason is that molded case circuit breakers and insulated case circuit breakers that have a short-time delay will also have an instantaneous trip setting that overrides the short-time delay at some fault level. Molded case circuit breakers with short time delay settings will have an instantaneous trip that overrides the short time delay, typically at a maximum of 10 times the amp rating. These instantaneous overrides are necessary to protect the circuit breakers for higher faults. The same simple procedure for evaluating circuit breakers with instantaneous trips can be used for this type circuit breaker, also. Merely read the manufacturer's literature to determine this instantaneous trip override setting. However, be certain to establish if the instantaneous trip pickup is given in symmetrical amps or asymmetrical amps. Some manufacturers specify the instantaneous override in asymmetrical amps which for practical evaluation purposes moves the instantaneous trip pickup setting to the left (picks up at lower symmetrical fault currents than perceived). See the next two pages for a brief discussion and curves of short-time delay settings and instantaneous overrides.

Circuit Breakers

Short-Time-Delay and Instantaneous Override

Some circuit breakers are equipped with short-time delay settings for the sole purpose of improving system coordination. Review the three curves on this page and the next page.

Circuit breaker short-time-delay (STD) mechanisms allow an intentional delay to be installed on low voltage power circuit breakers. Short-time-delays allow the fault current to flow for several cycles, which subjects the electrical equipment to unnecessarily high mechanical and thermal stress. Most equipment ratings, such as short circuit ratings for bus duct and switchboard bus, do not apply when short-time-delay settings are employed. The use of short-time-delay settings on circuit breakers requires the system equipment to be reinforced to withstand the available fault current for the duration of the short-time-delay. Ignoring equipment ratings in relation to the protective device opening time and let-through characteristics can be disastrous. Following is a time-current curve plot for two low voltage power circuit breaker with short-time delay and a 20A MCCB. The 100A CB has a STD set at 6 cycles and the 800A CB has a STD set at 24 cycles. This type of separation of the curves should allow for selective coordination, assuming that the breakers have been serviced and maintained per the manufacturer's requirements. This is an approach to achieve selective coordination that can diminish electrical safety and component protection.

An insulated case circuit breaker (ICCB) may also be equipped with short-time-delay. However, ICCBs will have a built-in override mechanism. This is called the instantaneous override function, and will override the STD for medium to high level faults. This override may "kick in" for faults as low as 12 times (12x) the breaker's amp rating. (See curve in left column on next page.) This can result in non-selective tripping of the breaker and load side breakers where overlaps occur. This can be seen in the example. (See curve in right column on next page.) As the overlap suggests, for any fault condition greater than 21,000A, both devices will open, causing a blackout.

Zone-Selective Interlocking

Zone-Selective Interlocking (ZSI), or zone restraint, has been available since the early 1990s. ZSI is designed to limit thermal stress caused by short-circuits on a distribution system. ZSI will enhance the coordination of the upstream and downstream molded case circuit breakers for all values of available short-circuit current up to the instantaneous override of the upstream circuit breaker.

Caution: Use of Circuit Breaker Short-Time Delay Settings May Negate Protection and Increase Arc-Flash Hazard

The longer an overcurrent is permitted to flow the greater the potential for component damage. The primary function of an overcurrent protective device is to provide protection to circuit components and equipment. A short-time delay (STD) setting on a circuit breaker can negate the function of protecting the circuit components. A low voltage power circuit breaker with a short-time delay and without instantaneous trip, permits a fault to flow for the length of time of the STD setting, which might be 6, 12, 18, 24 or 30 cycles. This typically is done to achieve fault coordination with downstream circuit breakers. However, there is an adverse consequence associated with using circuit breaker short-time delay settings. If a fault occurs on the circuit protected by a short time delay setting, a tremendous amount of damaging fault energy can be released while the system waits for the circuit breaker short-time delay to time out.

In addition, circuit breakers with short-time delay settings can drastically increase the arc-flash hazard for a worker. The longer an overcurrent protective device takes to open, the greater the flash hazard due to arcing faults. Research has shown that the arc-flash hazard can increase with the magnitude of the current and the time duration the current is permitted to flow. System designers and users should understand that using circuit breakers with short-time delay settings will greatly increase the arc-flash energy if an arcing fault incident occurs. If an incident occurs when a worker is at or near the arc-flash, the worker may be subjected to considerably more arc-flash energy than if an instantaneous trip circuit breaker or better yet a current-limiting circuit breaker or current-limiting fuses were protecting the circuit. The requirements for doing flash hazard analysis for worker safety are found in NFPA 70E "Electrical Safety Requirements for Employee Workplaces."

As an example, compare the photos resulting from investigative testing of arcing faults. Further information is provided in "Electrical Safety & Arc-Flash Protection" in this bulletin. A couple of comparison photos are shown on the next page. These tests and others are detailed in "Staged Tests Increase Awareness of Arc-Fault Hazards in Electrical Equipment", IEEE Petroleum and Chemical Industry Conference Record, September, 1997, pp. 313-322. This paper can be found on the Cooper Bussmann web site at www.cooperbussmann.com/services/safetybasics. One finding of this IEEE paper is that current-limiting overcurrent protective devices reduce damage and arc-fault energy (provided the fault current is within the current-limiting range).

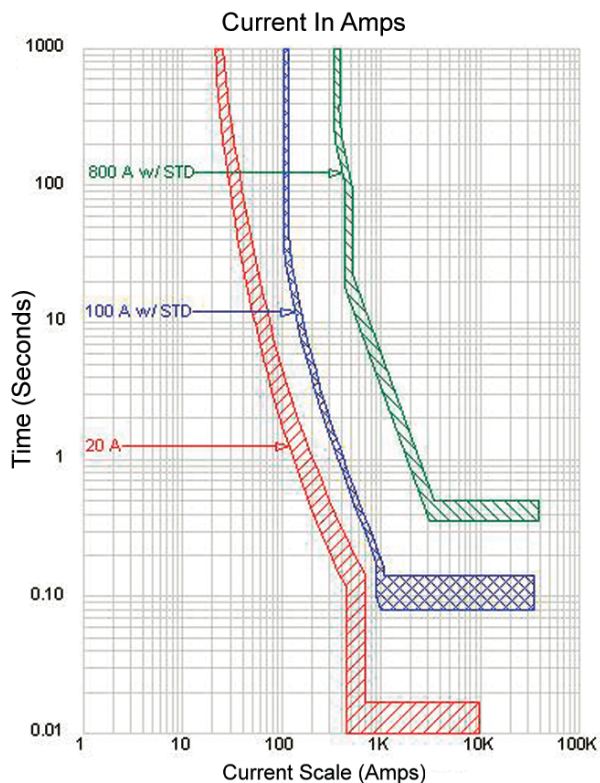

Low Voltage Power Circuit Breaker with Short-Time-Delay

Selective Coordination

Circuit Breakers

Insulated Case Circuit Breaker—Instantaneous Override

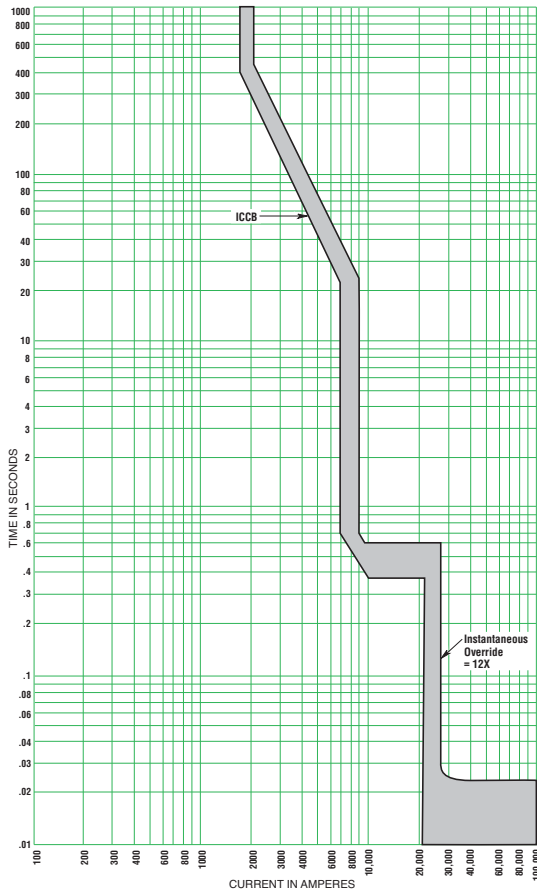

Instantaneous Override Opens at 21,000 Amps

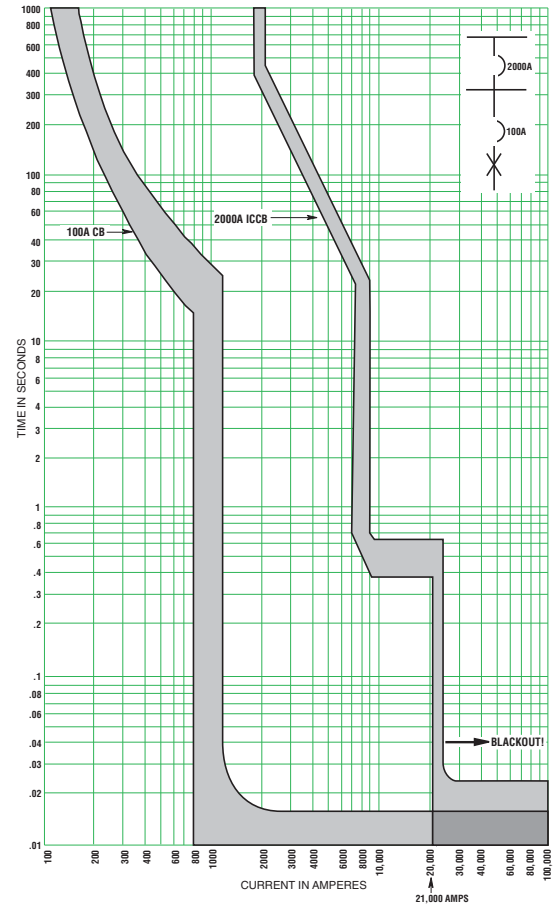

Test 4 shows sequential photos of a circuit protected by a circuit breaker with a short-time delay: interrupted at 6 cycles, so this incident lasted $\frac{1}{10}$ of a second. The arcing fault was initiated on a three phase, 480V system with 22,600A short circuit available.



Test 3 – Same test circuit as the prior photos, to the left, except the circuit is protected by KRP-C-601SP Cooper Bussmann Low-Peak® Current-Limiting Fuses. In this case these fuses limited the current and the fuses cleared in less than a $\frac{1}{2}$ cycle.

Current-limiting fuses or current-limiting circuit breakers can reduce the risks associated with arc-flash hazards by limiting the magnitude of the fault currents (provided the fault current is within the current-limiting range) and reducing the time duration of the fault. Test 3 photos, to the right, are from tests with the same test setup as shown in Test 4 above, except that KRP-C-601SP Low-Peak current-limiting fuses protect the circuit and clear the arcing fault in less than $\frac{1}{2}$ cycle. The arc-flash was greatly reduced because these fuses were in their current-limiting range. Also, the thermal and mechanical stresses on the circuit components that conducted the fault current were

greatly reduced. Recent arc-flash research has shown that arc-flash energy is linearly proportional to the time duration of the fault (given the fault currents are the same). Ignoring the fact that the KRP-C-601SP Low-Peak fuses in Test 3 limited the current let-through, the arc-flash energy released in Test 3 was approximately $\frac{1}{2}$ that of Test 4 just due to the faster operation of the KRP-C-601SP Low-Peak fuses (less than $\frac{1}{2}$ cycle clearing in Test 3 vs. 6 cycles clearing in Test 4). The actual arc-flash energy was reduced even more in Test 3 because of the current-limiting effect of the KRP-C-601SP Low-Peak fuses.