

# EJB Custom Control Panels

## Installation & Maintenance Information

**SAVE THESE INSTRUCTIONS FOR FUTURE REFERENCE**

### APPLICATION

EJB Custom Control Panels allow the grouping of control devices for process control, while utilizing a small amount of space.

EJB Custom Panels are suitable for use indoors or outdoors and are UL Classified and CSA Certified for Class I, Groups B\*, C, D; Class II, Groups E, F, G; Class III hazardous (classified) areas as defined by the National Electrical Code® and the Canadian Electrical Code®.

EJB series classified enclosures ordered with suffix -ATEX meet

the ATEX directive and are certified by ETL. EJB classified enclosures with -ATEX suffix have the following classification: (Ⓔ) II 2 G Ex d IIB + H2. ATEX certified boxes have an IP66 rating. ATEX suffix junction box complies with EN60079-0:2006 and EN60079-1:2006 Certificate ITSØ8 ATEX 15797U. ATEX certified boxes cannot be field drilled and tapped for entries. All entries must be drilled and tapped by Cooper Crouse-Hinds at the factory.

EJB Custom Control Panels should be installed, inspected, and maintained by qualified and competent personnel.

### INSTALLATION

#### ⚠ WARNING

1. To avoid damage to equipment or injury to personnel, electrical power must be off before and during installation and maintenance.
2. Field modification of this product is not permitted other than noted in this document.

1. EJB Custom Control Panels are furnished with or without drilled and tapped openings. Drilling and tapping of conduit openings and device openings in cover are subject to the

limitations of maximum size and number of openings as well as spacings. Refer to DRILLING AND TAPPING sections following. All machining must be done prior to installation.

2. Select a mounting location that will provide suitable strength and rigidity for supporting all contained wiring and control devices. Figure 1 shows the mounting dimensions for the four detachable mounting feet.

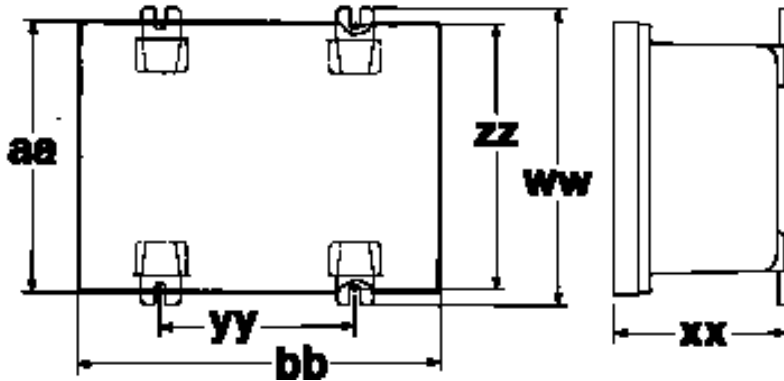

**IMPORTANT**  
ATEX certified boxes **MAY NOT**  
be field drilled and tapped.  
Entries must be machined by  
factory.

Catalog No.	DIMENSIONS (in.)								Net Wt. W/Cover (Lb.)
	Inside Depth **	aa	bb	Mtg. Hole	ww	xx	yy	zz	
EJB100806	6-3/8	13-1/32	15-1/32	9/16	12-1/4	8-9/16	5-1/2	11-1/4	60
121204	3-15/16	17-1/16	17-1/16	9/16	16-1/8	6-15/16	5-1/2	15-1/8	61
121206	5-15/16	17-1/16	17-1/16	9/16	16-1/8	8-9/16	5-1/2	15-1/8	71
121208	7-15/16	17-1/16	17-1/16	9/16	16-1/8	10-9/16	5-1/2	15-1/8	81
161606	5-15/16	21-3/16	21-3/16	9/16	20-1/4	8-9/16	9-1/2	19-1/8	93
161608	7-15/16	21-3/16	21-3/16	9/16	20-1/4	10-9/16	9-1/2	19-1/8	103
181206	5-15/16	17-5/16	23-5/16	9/16	16-3/8	8-9/16	11-1/2	15-1/8	96
181208	7-15/16	17-5/16	23-5/16	9/16	16-3/8	10-9/16	11-1/2	15-1/8	105
241208	7-15/16	17-9/16	29-9/16	9/16	16-5/8	11-5/16	17-1/2	15-1/8	147
241210	9-15/16	17-9/16	29-9/16	9/16	16-5/8	13-5/16	17-1/2	15-1/8	158
241808	7-15/16	23-9/16	29-5/8	11/16	23-1/2	11-13/16	17-1/4	21-7/8	248
241810	9-15/16	23-9/16	29-5/8	11/16	23-1/2	13-13/16	17-1/4	21-7/8	263
242408	7-15/16	23-9/16	29-9/16	11/16	29-1/2	11-13/16	16-1/4	27-7/8	297
242410	9-15/16	23-9/16	29-9/16	11/16	29-1/2	13-13/16	16-1/4	27-7/8	323
361208	7-15/16	16-5/16	40-5/16	9/16	16-1/8	11-5/8	29-1/2	15-1/8	187
361808	7-15/16	23-15/16	41-15/16	11/16	23-3/4	11-7/8	28-1/4	21-7/8	360
361810	9-15/16	23-15/16	41-15/16	11/16	23-3/4	14-1/4	28-1/4	21-7/8	399
362408	7-15/16	30-3/16	42-3/16	11/16	30-3/8	12-3/4	28-1/4	28-1/2	575

\*Groups C & D only w/ GUB window installed

\*\*Body and Cover

**Figure 1 EJB Custom Panel Dimensions**

© National Electrical Code is a Registered Trademark of the National Fire Protection Association.

© Canadian Electrical Code is a voluntary code for Adoption and Enforcement by Regulatory Authorities.

3. Install detachable mounting feet.
  - Insert four wedge-shaped mounting feet into dove-tail slots in enclosure body.
  - Tap each foot to securely tighten into slot.

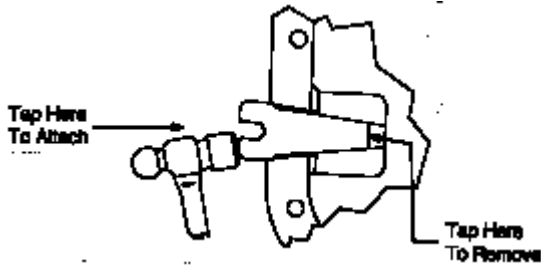

**Figure 2** Mounting Feet

4. Securely fasten enclosure to the mounting location, then attach into conduit system. Install approved conduit sealing fittings when required by Section 501.15 and/or 502.15 of the National Electrical Code plus any other applicable standards.

**⚠ CAUTION**

- Hazardous location information specifying class and group listing of each device is marked on the nameplate of each enclosure. Class and group listing for any device penetrating the enclosure must be suitable for the classification of the location in which the enclosure is installed.
- All unused conduit openings must be plugged. Listed plug must engage a minimum of five full threads and be a minimum of 1/8 inch thick.
- In Class I, Division 1, Group B locations, conduit sealing fittings **MUST** be installed in each attached conduit run (within eighteen inches of the enclosure) to comply with the latest edition of the National Electrical Code Section 501.15 and/or 502.15 plus any other applicable code.
- Conduit sealing fittings are required on all conduit entrances (within eighteen inches of the enclosure) for EJB361208, EJB361808, EJB361810, and EJB362408 enclosures when used in Class I, Div. 1, Group C hazardous areas. For other sealing requirements, consult the National Electrical Code®.

**⚠ CAUTION**

Do not use cover bolts as a means to lift the enclosure. Excessive force on the fully retracted cover bolts may damage the bolt/spring assembly.

**⚠ WARNING**

To avoid potential personal injury and/or damage to the ground-joint surface, do not remove the hinge bolts prior to loosening cover bolts.

- 5a. Loosen and make sure all cover bolts are fully retracted into the cover before attempting to open or close the cover. EJB enclosures are furnished with captive triple lead bolts that utilize a spring to aid and indicate full retraction of the bolts into the cover when opening and closing. (See Figure 3).

After all bolts are fully disengaged, firmly grasp the bottom and right side of cover and carefully swing aside to prevent damage to the ground joint surface. Avoid striking cover, or devices in cover, or neighboring enclosures or structures.

- 5b. To remove cover fully, two methods are recommended. Due to the potential weight of the cover, it must be supported prior to removal of hinge bolts. This can either be achieved by a second installer holding the cover or by utilizing a hoist. If a hoist is to be used, first remove the two hex bolts (not the cover bolts) located on short side opposite edges on the cover. Then install two 3/8-16 eyebolts (not provided) into these two 3/8-16 threaded holes. **It is important that the eyebolts be threaded only part way through the cover, preventing damage to the machined flange on the body.**

Loosen and remove the hinge bolts. Carefully remove both sides of hinges. Lift off cover carefully and set it aside to prevent damage to the ground joint and flange gasket.

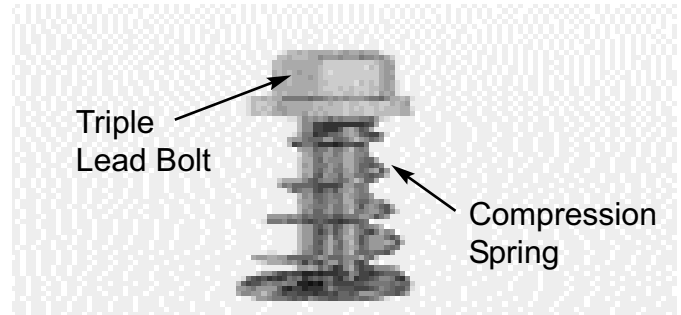

**Figure 3**

**⚠ CAUTION**

Hammers or prying tools must not be allowed to damage the flat ground-joint surfaces or cover gasket. Do not handle covers roughly, or place them on surfaces that might damage or scratch the flat ground-joint surfaces.

6. Pull wires into enclosure, making sure they are long enough to make the required connections. Make all electrical connections. The internal grounding terminal shall be used as equipment grounding means. The external terminal is only a supplemental bonding connection.
7. Test wiring for correctness with continuity checks and also for unwanted grounds with insulation resistance tester.

**⚠ CAUTION**

Clean both ground-joint surfaces of body and cover before closing. Dirt or foreign material must not accumulate on flat ground-joint surfaces. Surfaces must seat fully against each other to provide a proper explosionproof seal.

8. To install/close cover, make sure cover and body ground-joint surfaces are clean and not scratched. Lift cover to approximate position and line up bolt holes of cover with body using the guide post provided. Avoid sliding ground-joint surface of cover over ground-joint surface of body. Cover/body bolt holes must match up. Hand start corner bolts. Fully tighten all cover bolts (torque to 40-45 ft. lbs.). If removed previously, reinstall hinge bolts (torque to 8 ft. lbs.).
9. Pour sealing compound into sealing fittings (when required) in accordance with the instructions supplied with each of the approved fittings and sealing compound.

**BREATHER AND DRAIN**

**⚠ CAUTION**

Check breather and/or drain or their carton label to be certain that they are suitable for the hazardous location (class and group) and environmental rating as marked on the enclosure nameplate.

**DRILLING AND TAPPING FOR ENTRIES (ATEX Certified boxes must have all drilled and tapped entries machined at Cooper Crouse-Hinds factory)**

- To comply with the NEC Section 344.28 and 344.46, all conduit entries must be provided with a smooth rounded entry into the enclosure. This may be accomplished in various ways, including the use of Crouse-Hinds RE reducers or by using LNR series conduit liners.

The location, quantity, and maximum sizes of conduit openings must be in accordance with Table 1A, 1B, and 1C, and 1D.

- Female conduit must be taper tapped with the thread form and taper (3/4 in. per ft.) conforming to NPT. A standard NPT male gage must enter the tapped opening 1-1/2 minimum turns past the gage notch. Openings are tapped deeper than standard NPT gage to ensure a minimum of five full threads engagement with standard NPT threaded conduit (refer to NEMA FB-1-4.01).

If more than eight (8) conduit entries, or a mix of conduit entry trade sizes are needed in any wall of the enclosure, use the following instructions:

- From Table 1A, determine how many 5" conduit entries are permitted on a side.† For example, a quantity of (4) 5" entries are permitted on the long side of an EJB361808.
- For each 5" conduit entry permitted†, one may substitute a quantity of smaller conduit entry trade sizes.
- Some smaller enclosures cannot accept a 5" opening, in which case, the maximum number of 3-1/2" or 1-1/2" conduit openings must be determined (again, using Table 1A).

† These instructions can be used for ATEX and Group B locations, provided no entry machined in the wall of the enclosure exceeds 4" trade size.

### CONDUIT ARRANGEMENTS TABLES

**Table 1A** Conduit Openings: Maximum quantity and sizes (For "Defined Area" Dimensions, See Table 1B Below)  
Style C Drilled and Tapped Openings - Groups B\*\*\*, C and D)  
(For "Conduit Spacing Locations" See Table 1C Attached)

Cat. #	Maximum Trade Size and Number of Openings Top and Bottom(bb)††								Sides (aa)							
	1	2	3	4	5	6	7	8	1	2	3	4	5	6	7	8
EJB100806	3 1/2	3	1 1/2	1 1/4	-	-	-	-	3 1/2	2 1/2	1 1/4	3/4	-	-	-	-
EJB121204	1 1/2	1 1/2	1 1/2	1 1/2	1	3/4	1/2	-	1 1/2	1 1/2	1 1/2	1 1/4	1	3/4	1/2	-
EJB121206	3 1/2	3 1/2	1 1/2	1 1/2	1	3/4	1/2	-	3 1/2	3 1/2	1 1/2	1 1/4	1	3/4	1/2	-
EJB121208	5	3 1/2	1 1/2	1 1/2	1	3/4	1/2	-	5	3 1/2	1 1/2	1 1/4	1	3/4	1/2	-
EJB161606	3 1/2	3 1/2	2 1/2	2	1 1/2	1 1/4	1	3/4	3 1/2	3 1/2	2 1/2	2	1 1/2	1 1/4	1	3/4
EJB161608	5	5	3	2	1 1/2	1 1/4	1	3/4	5	5	3	2	1 1/2	1 1/4	1	3/4
EJB181206	3 1/2	3 1/2	3 1/2	2 1/2	1 1/2	1 1/2	1	3/4	3 1/2	3 1/2	1 1/2	1 1/4	1	3/4	1/2	-
EJB181208	5	5	3 1/2	2 1/2	2	1 1/2	1	1	5	3 1/2	1 1/2	1 1/4	1	3/4	1/2	-
EJB241208	5	5	5	3 1/2	3	2 1/2	2	1 1/2	5	3 1/2	1 1/2	1 1/4	1	1	1/2	-
EJB241210	6	6	5	3 1/2	3	2 1/2	2	1 1/2	6	3 1/2	1 1/2	1 1/4	1	1	1/2	-
EJB241808	5	5	5	3 1/2	3	2 1/2	2	1 1/2	5	5	3 1/2	2 1/2	2	1 1/2	1 1/4	1
EJB241810	6	6	5	3 1/2	3	2 1/2	2	1 1/2	6	6	3 1/2	2 1/2	2	1 1/2	1 1/4	1
EJB242408	5	5	5	3 1/2	3	2 1/2	2	1 1/2	5	5	5	3 1/2	3	2 1/2	2	1 1/2
EJB242410	6	6	5	3 1/2	3	2 1/2	2	1 1/2	6	6	5	3 1/2	3	2 1/2	2	1 1/2
EJB361208	5	5	5	5	4	4	3 1/2	2 1/2	5	3 1/2	1 1/2	1 1/4	1	3/4	1/2	-
EJB361808	5	5	5	5	4	4	3 1/2	2 1/2	5	5	3 1/2	2 1/2	2	1 1/2	1 1/4	1
EJB361810	6	6	5	5	4	4	3 1/2	2 1/2	6	6	3 1/2	2 1/2	2	1 1/2	1 1/4	1
EJB362408	5	5	5	5	4	4	3 1/2	2 1/2	5	5	5	3 1/2	3	2 1/2	2	1 1/2

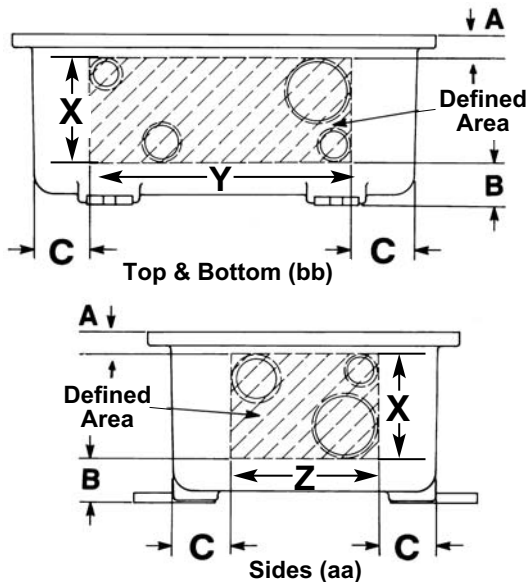

Cat #	Outlined Dimensions Defined Area			Dimensions Defined Area		
	A	B	C	X	Y	Z
EJB100806	1-1/8	1-3/4	1-1/4	4.46	9.25	7.25
EJB121204	1-1/8	1-3/4	1-1/4	2.38	11.31	11.31
EJB121206	1-1/8	1-7/8	1-1/4	4.32	11.13	11.13
EJB121208	1-1/8	1-7/8	1-1/4	6.38	11.06	11.06
EJB161606	1-1/8	2	1-1/4	4.19	15.13	15.13
EJB161608	1-1/8	2	1-1/4	6.19	15.06	15.06
EJB181206	1-1/8	2	1-1/4	4.23	16.50	10.50
EJB181208	1-1/8	2	1-1/4	6.22	16.44	10.44
EJB241208	1-7/16	2	1-3/8	5.97	23.43	11.43
EJB241210	1-7/16	2	1-3/8	7.97	23.36	11.36
EJB241808	1-7/16	2-5/8	1-3/8	5.85	23.08	17.06
EJB241810	1-7/16	2-5/8	1-3/8	7.85	23.01	17.01
EJB242408	1-7/16	2-11/16	1-3/8	5.85	23.08	23.08
EJB242410	1-7/16	2-11/16	1-3/8	7.85	23.01	23.01
EJB361208	1-7/16	2	1-3/8	5.92	34.97	10.97
EJB361808	1-7/16	2-13/16	1-3/8	5.83	35.08	17.08
EJB361810	1-7/16	2-5/16	1-5/8	8.29	35.40	17.40
EJB362408	1-7/16	3-1/4	2	5.56	35.05	23.05

**TABLE 1B** Defined Area Dimensions

†† Top and bottom are the longer dimensions on enclosures which are not square.

\*\*\*Maximum conduit size permitted in Group B locations is 4".

# Cover Hole Pattern (Top View)

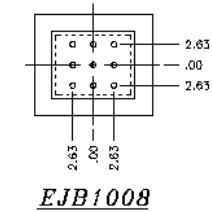
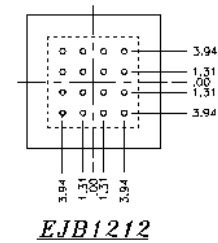
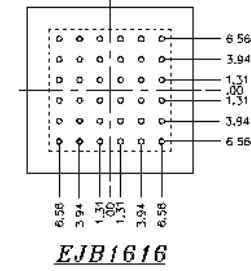
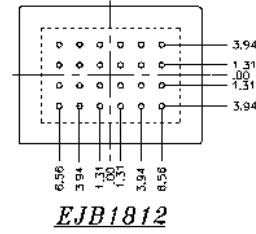
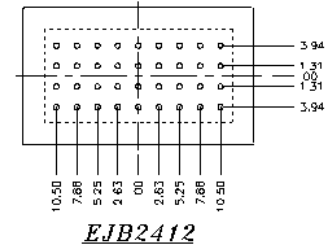
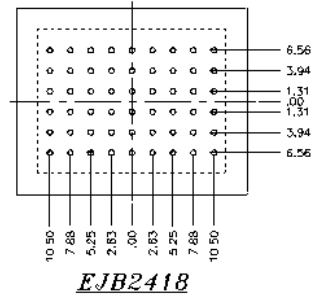
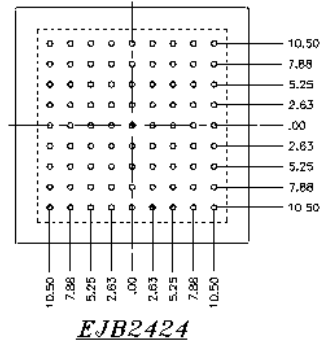
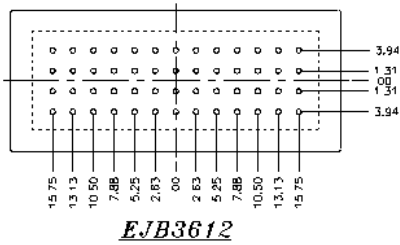
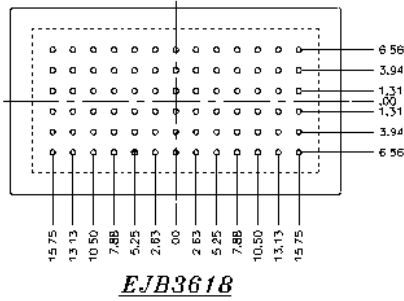
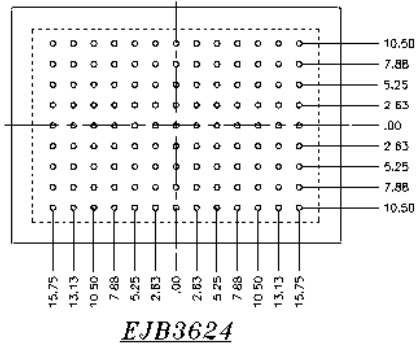

**Figure 4**



DRILLED AND TAPPED CONDUIT OPENINGS MINIMUM CENTER-TO-CENTER DISTANCE (IN.)												
Conduit Size	1/2	3/4	1	1-1/4	1-1/2	2	2-1/2	3	3-1/2	4	5	6
1/2	1-1/2											
3/4	1-5/8											
1	1-3/4	1-3/4	2									
1-1/4	2	2-1/8	2-1/4	2-1/2								
1-1/2	2-1/8	2-1/4	2-3/8	2-5/8	2-3/4							
2	2-3/8	2-1/2	2-5/8	2-7/8	3	3-1/4						
2-1/2	2-3/4	2-7/8	3-1/8	3-1/4	3-3/8	3-5/8	3-7/8					
3	3-1/8	3-1/4	3-3/8	3-1/2	3-5/8	4	4-1/4	4-5/8				
3-1/2	3-3/8	3-1/2	3-5/8	3-7/8	4	4-1/4	4-1/2	4-7/8	5-1/8			
4	3-3/4	3-7/8	4	4-1/8	4-1/4	4-1/2	4-7/8	5-1/8	5-3/8	5-3/4		
5	4-3/4	4-7/8	5	5-1/8	5-1/4	5-1/2	5-3/4	6-1/8	6-3/8	6-5/8	7-1/4	
6	5-1/4	5-3/8	5-1/2	5-3/4	5-7/8	6-1/8	6-3/8	6-5/8	6-7/8	7-1/8	7-3/4	8-1/4

Minimum clearance for unions only.

**TABLE 3**

• Metric openings must be in accordance with Table 1D and have a class 6H fit (refer to ISO 965-1 and ISO 965-3). In Division 1 Group B areas, fittings must have a minimum of eight full threads engagement. In Division 1 Group C, D areas, fittings must have a minimum of five full threads engagement. The location, quantity, and maximum sizes of metric openings must be in accordance with Table 1A, 1B, and 1C. Use Table 1D to determine the equivalent of NPT sizes.

**Note:** Per NEC and UL requirements, all metric entries must be permanently marked and identified, or listed metric to NPT adapters provided, or metric cable glands must be used.

- For conduit entries with non-interfering vertical seals: center-to-center distance is the total of: 1/2 the outside diameter of the larger conduit plus the turning radius of the sealing fitting used in the smaller conduit plus 1/4 inch clearance.
- For conduit entries with non-interfering horizontal seals: center-to-center distance is the total of: 1/2 of the outside diameter of the larger conduit plus the turning radius of the sealing fitting used in the smaller conduit plus 2 inches clearance for pouring.

**CAUTION**

While the number of openings derived from the above will result in a safe configuration, the number of openings could be reduced if center-to-center spacings were required to be increased for the following reason:

- If sealing fittings are required to be installed in the conduit, sufficient room must be provided to install, pack, and pour the fitting after the conduit and fittings are installed and the conductors are in place. This is particularly important in horizontal conduit runs, when fittings are directly over one another.

**CAUTION**

The space between drilled & tapped conduit entries is a factor of the following considerations:

- Ability to install conduit with a variety of fittings (for various reasons, the conduit which is to be threaded into each conduit entry may, in turn, be threaded into a variety of fittings including (but not limited to) the following: unions, sealing fittings of various types, and GUA type fittings. Dimensions of these fittings are provided in the Crouse-Hinds catalog, and should be referred to in planning a conduit layout).
- All drilled and tapped conduit entries must fall completely within the defined areas as specified in Table 1B.

**FIELD DRILLING AND TAPPING FOR LISTED EMP DEVICES (Plate aluminum covers only)**

(ATEX Certified boxes must have all drilled and tapped entries machined at Cooper Crouse-Hinds factory)

Maximum quantity, location, and minimum spacing of device holes for field drilling are subject to limits shown in Figure 4.

Mark appropriate hole locations. Drill or bore .938 diameter through hole perpendicular to cover surface. Tap 3/4-14 NPSM. Visually examine for continuous well-formed thread and gage with standard 3/4-14 NPSM Go/No-Go thread gage. Install EMP device or 3/4-14 NPSM closure plug ensuring at least eight full thread engagement.

Refer to IF 872 for operation and maintenance of EMP devices.

**Note:** The required closure plug should be ordered from Crouse-Hinds as follows: EMP closure plug 0207959 or EMP ATEX PLUG 0208466.

**FOR ATEX ENCLOSURES:**

- Before opening the enclosure in a flammable atmosphere, circuits must be

*All statements, technical information and recommendations contained herein are based on information and tests we believe to be reliable. The accuracy or completeness thereof are not guaranteed. In accordance with Crouse-Hinds "Terms and Conditions of Sale," and since conditions of use are outside our control, the purchaser should determine the suitability of the product for his intended use and assumes all risk and liability whatsoever in connection therewith.*

interrupted.

- The approval applies to equipment without cable glands. When mounting the flameproof enclosure in a hazardous area, only rigid metal conduit systems or flameproof cable glands certified to EN60079 must be used.
- All unused conduit entries must be closed with a flameproof plug certified to EN60079.
- Any components attached or installed (e.g. terminal compartments, bushings, explosionproof cable entries, connectors) shall be of a technical standard that complies with the specifications on the cover sheet as minimum and for which a separate type examination certificate has been issued. The operating conditions set forth in the relevant component certificates must by all means be complied with.

Securely fasten enclosure to the mounting location, then attach into conduit system.

The EJB shall be connected by means of suitable cable entries or conduit systems, which meet the requirements of EN60079-1, Sections 13.1 and 13.2, and for which a separate type examination certificate has been issued.

Terminate ground wire with 5/16" ring terminal appropriately sized for ground wire gauge (10 AWG minimum). Install ground wire such that it cannot become loose or twisted.

The enclosure is intended for wiring connections only, or for controller devices or other equipment which fall within the electrical parameters indicated above.

Cable entries (conduit threads) and sealing plugs of simple designs must not be used. Should the EJB be connected by means of a conduit entry which has been approved for this purpose, the required sealing device shall be provided immediately at the terminal box.

Any openings not used shall be sealed as specified in EN60079-0, Section 13.3.

The connecting wire of the EJB shall be installed to provide for permanent wiring and adequate protection against mechanical damage.

If the temperature at entry fittings should exceed 70°C, the connecting cables used have to be of the temperature-resistant type.

**MAINTENANCE**

**WARNING**

**To avoid electrical shock or risk of ignition:**

Always disconnect primary power source before opening enclosure for inspection or service.

1. Frequent inspection should be made. A schedule for maintenance check should be determined by the environment and frequency of use. It is recommended that it should be at least once a year.
2. Perform visual, electrical, and mechanical checks on all components on a regular basis.
  - Visually check for undue heating evidenced by discoloration of wires or other components, damaged or worn parts, or leakage evidenced by water of corrosion in the interior.
  - Electrically check to make sure that all connections are clean and tight and that contacts in the components make or break as required.
  - Mechanically check that all parts are properly assembled, and operating mechanisms move freely.
3. Do not attempt field replacement or repair of cover gasket. Instead, remove damaged gasket and continue to use cover without gasket. This will assure safety for use in Class I and Class II hazardous (classified) locations. However, the enclosure will **not be** watertight.

**CAUTION**

Clean both ground-joint surfaces of body and cover before closing. Dirt or foreign material must not accumulate on flat ground-joint surfaces. Surfaces must seat fully against each other to provide a proper explosionproof seal.

Cooper Crouse-Hinds recommends an Electrical Preventative Maintenance Program as described in the National Fire Protection Association Bulletin NFPA 70B.

**REPLACEMENT PARTS**

EJB, Style C Model M82 Series Junction boxes are designed to provide years of reliable service. However, should the need for replacement parts arise, they are available through your Cooper Crouse-Hinds Distributor. Assistance may also be obtained through your Cooper Crouse-Hinds Sales Representative or the Cooper Crouse-Hinds Customer Service Department.