

9000X Series AF drives— MotoRx dV/dt filters



Contents

Description	Page
Introduction	2
MotoRx dV/dt filter kit operation	2
Parts included with the MotoRx dV/dt filter kits	2
Mounting dimensions	3
Mounting guidelines	4
Mounting instructions	4
Wiring guidelines	5
Wiring diagrams	5
Ordering information	6

⚠ WARNING!

ALL ELECTRICAL INSTALLATION AND MAINTENANCE WORK ON THE MOTORX DV/DT FILTER SHOULD ONLY BE CARRIED OUT BY QUALIFIED ELECTRICIANS.

⚠ WARNING!

DO NOT ATTEMPT ANY WORK ON POWERED UNITS. COMPONENTS AND COMPONENT BOARDS INSIDE THE ADJUSTABLE FREQUENCY DRIVE AND MOTORX DV/DT FILTER COMPONENTS MAY BE AT INCOMING VOLTAGE POTENTIAL WHEN THE AFD IS CONNECTED TO SUPPLY VOLTAGE. COMING IN CONTACT WITH LIVE COMPONENTS IS EXTREMELY DANGEROUS AND MAY CAUSE DEATH OR SERIOUS INJURY.

NO WARRANTIES, EXPRESS OR IMPLIED, INCLUDING WARRANTIES OF FITNESS FOR A PARTICULAR PURPOSE OR MERCHANTABILITY, OR WARRANTIES ARISING FROM COURSE OF DEALING OR USAGE OF TRADE, ARE MADE REGARDING THE INFORMATION, RECOMMENDATIONS, AND DESCRIPTIONS CONTAINED HEREIN. In no event will Eaton be responsible to the purchaser or user in contract, in tort (including negligence), strict liability or otherwise for any special, indirect, incidental or consequential damage or loss whatsoever, including but not limited to damage or loss of use of equipment, plant or power system, cost of capital, loss of power, additional expenses in the use of existing power facilities, or claims against the purchaser or user by its customers resulting from the use of the information, recommendations, and descriptions contained herein. The information contained in this document is subject to change without notice.



Powering Business Worldwide

Introduction

MotoRx™ dV/dt filter kit operation

The MotoRx dV/dt filter is comprised of a 0.5% impedance line reactor, followed by capacitive filtering and an energy recovery/clamping circuit. The filter is used to reduce the dV/dt of the adjustable frequency drive (AFD) output waveform. A three-phase diode bridge clamps the output voltage to the AFD's internal DC bus through resistors. The energy in the voltage peaks is primarily recovered for reuse by the AFD with some resistor losses.

Parts included with the MotoRx dV/dt filter kits

Table 1. 1000 V/μs, 500V MotoRx dV/dt Filter Kits

Code Number	Resistor Assembly Part Number and Mounting Hardware	Clamp Board Part Number and Mounting Hardware	Output Reactor Part Number and Mounting Hardware	Other
MotoRx1000-5010	Part No. 015-000330-0800 Two (2) 10–32 x 0.5 self-tapping screws	Part No. 015-001092-0011 Four (4) 1/4-turn standoffs, black Three (3) 22–18 AWG male terminals	Part No. 064-001073-001 Four (4) 0.25–20 x 0.62 screws Four (4) 1/4-inch flat washers	One (1) motor lead label One (1) terminal block
MotoRx1000-5020	Part No. 015-000330-0800 Two (2) 10–32 x 0.5 self-tapping screws	Part No. 015-001092-0011 Four (4) 1/4-turn standoffs, black Three (3) 22–18 #10 ring lugs	Part No. 064-001073-0002 Four (4) 0.25–20 x 0.62 screws Four (4) 1/4-inch flat washers Six (6) #8 ring lugs Six (6) 10–32 x 0.5 hex screws Six (6) Belleville spring washers Six (6) #10 flat washers Six (6) 10–32 hex nuts	One (1) motor lead label One (1) terminal block Two (2) 6–32 x 1 Phillips head screws
MotoRx1000-5030	Part No. 015-000330-0800 Two (2) 10–32 x 0.5 self-tapping screws	Part No. 015-001092-0011 Four (4) 1/4-turn standoffs, black	Part No. 064-001073-0003 Four (4) 0.25–20 x 0.62 hex screws Four (4) 1/4-inch flat washers	One (1) motor lead label One (1) terminal block Two (2) 6–32 x 1 Phillips head screws
MotoRx1000-5050	Part No. 015-000330-0801 Two (2) 10–32 x 0.5 self-tapping screws	Part No. 015-001092-0012 Four (4) 1/4-turn standoffs, black	Part No. 064-001073-0004 Four (4) 0.25–20 x 0.62 hex screws Four (4) 1/4-inch flat washers Six (6) 0.25–20 x 0.62 hex screws Six (6) Belleville spring washers Six (6) 1/4-inch flat washers Six (6) 0.25–20 hex nuts Six (6) #6 ring lugs	One (1) motor lead label One (1) terminal block Two (2) 8–32 x 0.75 screws
MotoRx1000-5075	Part No. 015-000330-0802 Two (2) 10–32 x 0.5 self-tapping screws	Part No. 015-001092-0013 Three (3) 22–16 #1/4 ring lug Four (4) 1/4-turn standoffs, black	Part No. 064-001073-0005 Four (4) 0.25–20 x 0.62 hex screws Four (4) 1/4-inch flat washers Six (6) 0.25–20 x 0.62 hex screws Six (6) Belleville spring washers Six (6) 1/4-inch flat washers Six (6) 0.25–20 hex nuts Six (6) #4 ring lugs	One (1) motor lead label One (1) terminal block Two (2) 8–32 x 0.75 screws
MotoRx1000-5100	Part No. 015-000330-0802 Two (2) 10–32 x 0.5 self-tapping screws	Part No. 015-001092-0014 Three (3) 22–16 #1/4 ring lugs Four (4) 1/4-turn standoffs, black	Part No. 064-001073-0006 Four (4) 5/16-18 x 0.75 self-tapping screws Four (4) 5/16-inch flat washers Six (6) 0.25–20 x 0.62 hex screws Six (6) 0.25–20 hex nuts Six (6) 1/4-inch flat washers Six (6) Belleville spring washers Six (6) #2 ring lugs	One (1) motor lead label One (1) terminal block Two (2) 8–32 x 0.75 screws

Mounting dimensions

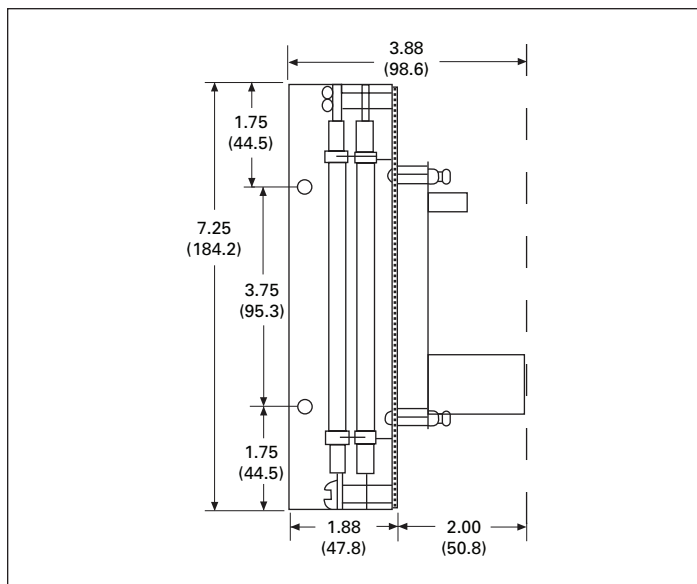

Figure 1. Resistor and Clamp Board Assembly Dimensions

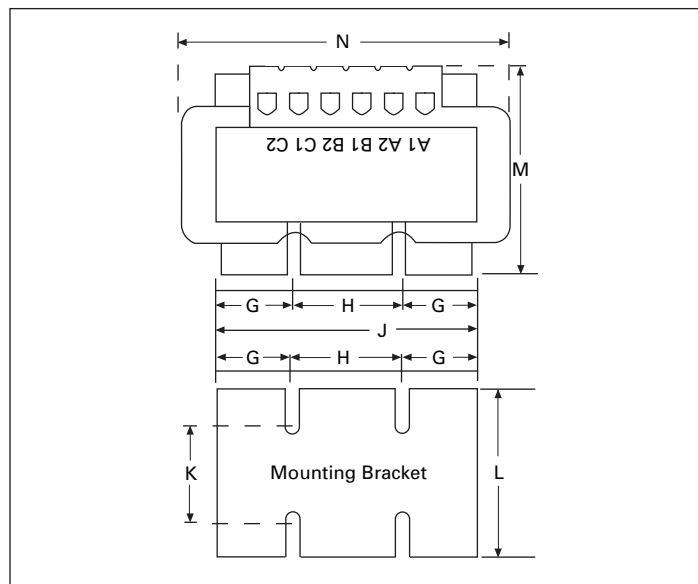

Figure 2. Output Reactor Dimensions (See Table 2 Below)

Table 2. Output Reactor Dimensions

Code Number	Mounting Plate Inches (mm)					Output Reactor Inches (mm)		
	G	H	J	K	L	M (Max.)	N (Max.)	Depth (Max.)
MotoRx1000-5010	0.72 (18.3)	2.00 (50.8)	3.44 (87.4)	1.64 (41.7)	2.51 (63.8)	4.00 (101.6)	5.00 (127.0)	4.00 (101.6)
MotoRx1000-5020	0.72 (18.3)	2.00 (50.8)	3.44 (87.4)	1.64 (41.7)	2.51 (63.8)	3.50 (88.9)	5.00 (127.0)	4.00 (101.6)
MotoRx1000-5030	1.34 (34.0)	1.90 (48.3)	4.57 (116.1)	2.15 (54.6)	3.45 (87.6)	4.00 (101.6)	6.00 (152.4)	5.00 (127.0)
MotoRx1000-5050	1.27 (32.3)	1.80 (45.7)	4.33 (110.0)	2.03 (51.6)	3.27 (83.1)	4.95 (125.7)	6.00 (152.4)	5.00 (127.0)
MotoRx1000-5075	1.27 (32.3)	1.80 (45.7)	4.33 (110.0)	2.03 (51.6)	3.27 (83.1)	4.95 (125.7)	6.00 (152.4)	5.00 (127.0)
MotoRx1000-5100	1.22 (31.0)	2.43 (61.7)	4.86 (123.4)	2.02 (51.3)	2.73 (69.3)	4.05 (102.9)	8.00 (203.2)	5.75 (146.1)

Mounting guidelines

- Mount the resistor and clamp board assembly and output reactor near the output of the drive to minimize long wiring runs between components
 - The resistor and clamp board assembly should be mounted less than 2 ft away from the drive terminals
 - The output reactor should be mounted less than 2 ft away from the drive terminals
 - Maintain a minimum 1-inch space between the clamp board and the output reactor
- Mount the terminal block near the drive
- Orient filter kit components as shown in **Figure 3** below

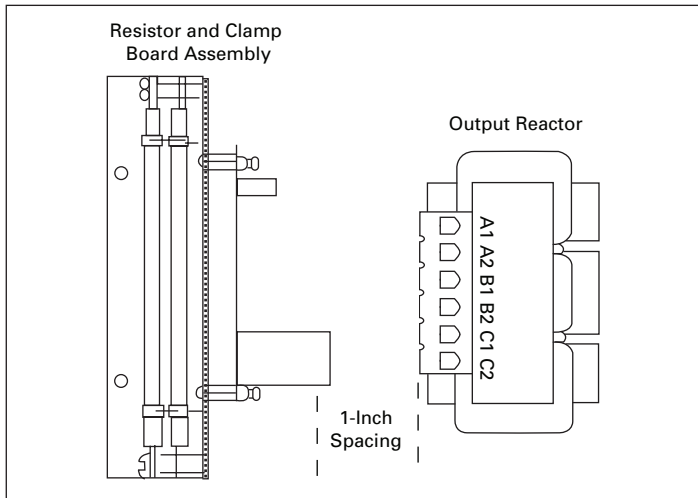

Figure 3. Mounting Orientation and Component Spacing

Mounting instructions

1. Mount the clamp board to the resistor assembly, using the four 1/4-turn standoffs as in **Figure 4** below.

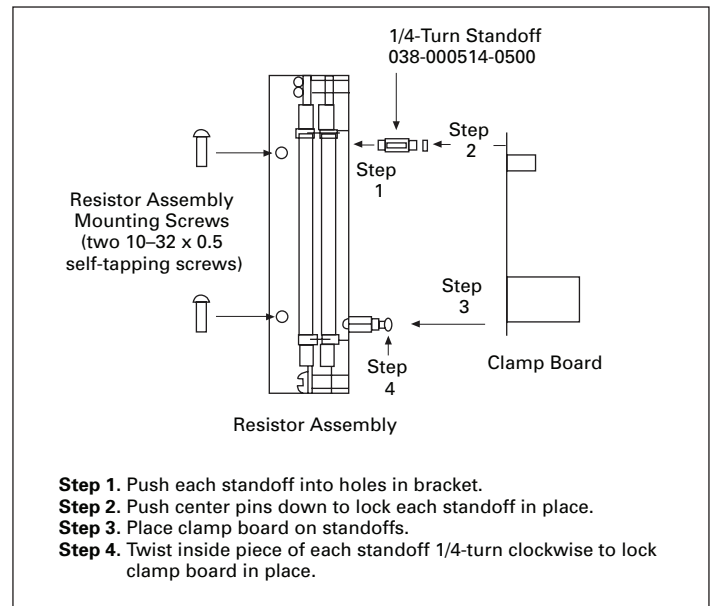

Figure 4. Resistor and Clamp Board Assembly

2. Mount the resistor assembly bracket to the panel, using the two 10-32 x 0.5 self-tapping screws.
3. Mount the output reactor to the drive housing, using the four 0.25-20 x 0.62 self-tapping hex screws and 1/4-inch flat washers, as show in **Figure 5** below.

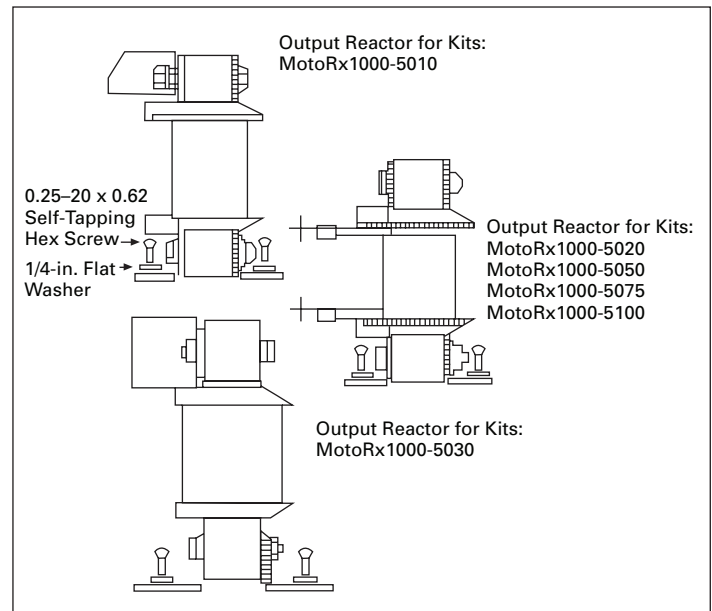

Figure 5. Output Reactor Mounting

4. Mount the terminal block to the drive housing in a convenient location, using two 6-32 x 1 Phillips mounting screws.
5. Affix the terminal block label to the drive housing to indicate the appropriate motor lead locations.

Wiring guidelines

Follow all applicable NEC® and local regulations when wiring MotoRx dV/dt filter kits.

⚠ IMPORTANT!

ALL ELECTRICAL INSTALLATION AND MAINTENANCE WORK ON MOTORX DV/DT FILTER KITS SHOULD ONLY BE CARRIED OUT BY QUALIFIED ELECTRICIANS.

When wiring the output reactor to the motor terminals and to the drive terminals, use the wire sizes recommended in **Table 3**.

Wiring diagrams

Connect the drive, resistor and clamp assembly, and output reactor as shown in **Figure 6** below.

Table 3. Recommended Wire Sizing

Code Number	Recommended Wire Sizing (Based on 600V, 105°C Rated Wire)
MotoRx1000-5010	#10 AWG (6 mm ²)
MotoRx1000-5020	#8 AWG (10 mm ²)
MotoRx1000-5030	#6 AWG (16 mm ²)
MotoRx1000-5050	#6 AWG (16 mm ²)
MotoRx1000-5075	#4 AWG (25 mm ²)
MotoRx1000-5100	#2 AWG (35 mm ²)

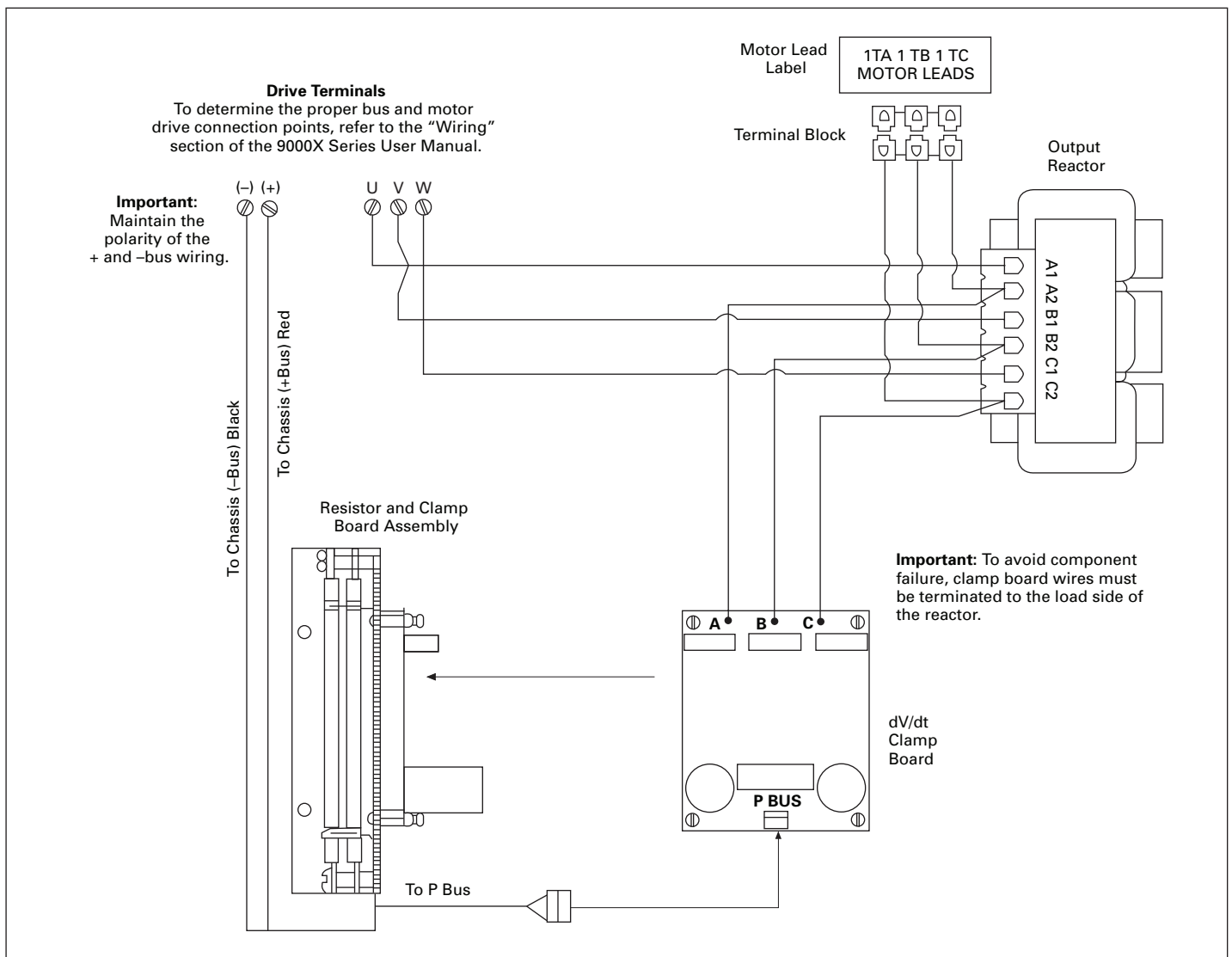

Figure 6. Wiring the MotoRx dV/dt Filter Kit

Output reactors with wire lug connections are wired as shown in **Figure 7** below. Lug connections should be tightened to 60 lbs torque.

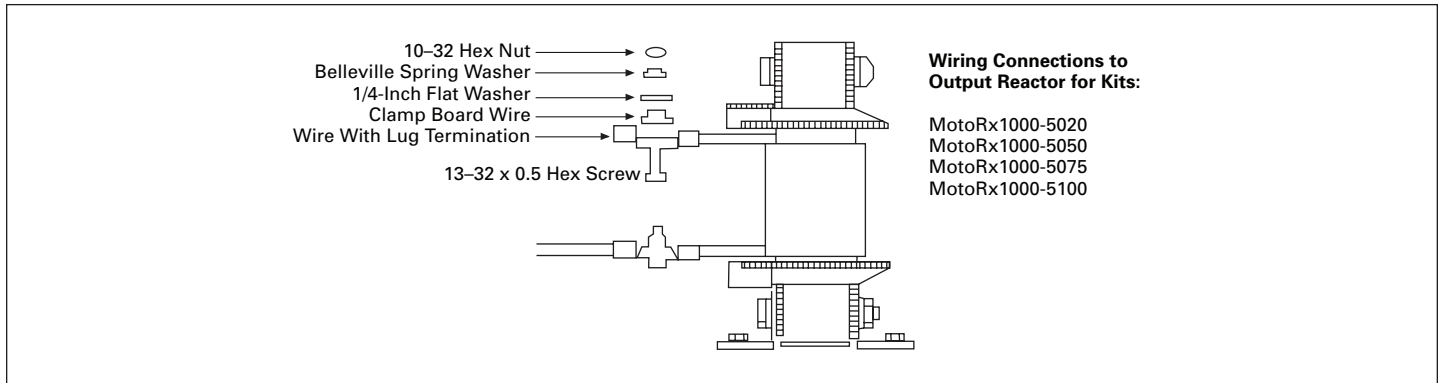

Figure 7. Output Reactor Wiring Connections

Ordering information

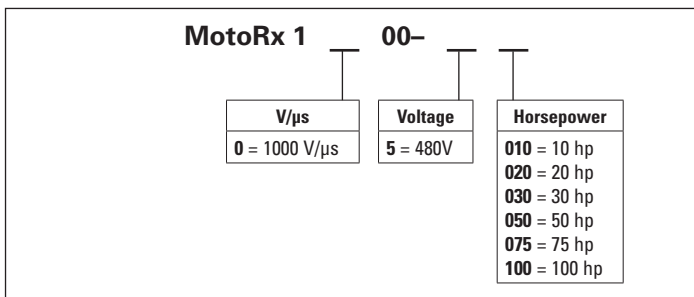

Figure 8. MotoRx dV/dt Filter Kit Ordering Matrix

Table 4. Ordering Information

Code Number	Horsepower
MotoRx1000-5010	1–10
MotoRx1000-5020	15–20
MotoRx1000-5030	25–30
MotoRx1000-5050	40–50
MotoRx1000-5075	60–75
MotoRx1000-5100	100

Eaton Corporation
Electrical Sector
1111 Superior Ave.
Cleveland, OH 44114
United States
877-ETN-CARE (877-386-2273)
Eaton.com

© 2009 Eaton Corporation
All Rights Reserved
Printed in USA
Publication No. IL04012002E / Z9135
September 2009



**PowerChain
Management®**

PowerChain Management is a registered trademark of Eaton Corporation.

All other trademarks are property of their respective owners.