

TABLE OF CONTENTS

1	Introduction / Application Procedure
2	Simplified Block Diagram / Overview
3	Front Panel Features
4	Front Panel Operation
5	Function Code Introduction and List
10	Terminal Descriptions / Wiring Information
12	Wiring Diagrams
17	Simplified I/O Schematics
18	Serial Communication: Overview / Standard Format
19	Enhanced Communication Format
22	Communication: Wiring / Networking
26	Block Diagram
28	Diagnostics / Troubleshooting
30	Specifications
31	Parts and Accessories
32	Dimensions / Warranty Information

INTRODUCTION

GENERAL DESCRIPTION

The Durant High Speed President is a micro-processor based count control device with three times the count speed and twice the positional resolution capability of other President series controls. The maximum count input speed is 30 kHz. Programmable count input modes include quadrature x1, x2, and x4 resolution selections.

The device has a six digit dual preset main counter with scaling, a six digit single preset batch counter, and a six digit 1/tau rate meter with scaling. The two main counter presets can be configured to operate as a standard dual preset control or as a single preset control with prewarn. The unit includes an option for entering presets "on the fly" to prevent counting past a new preset.

There are three sets of transistor outputs (one for each preset) and two form "C" relay outputs. The transistor outputs have a fast response time required for accurate high speed control. The relay outputs are unassigned and may be connected to any of the transistor outputs. The control also features four programmable inputs, each of which may be used for one of eight functions.

The High Speed President includes two communication modes. The standard mode is compatible with existing President series products. The enhanced mode has additional features and allows a host computer more control over the unit.

This counter has a non-volatile memory that retains all count, preset, and function code information while power off. Once programmed, the unit will not require reprogramming unless there is a need to alter its operation.

APPLICATION PROCEDURE

Because of the 58867-400's versatility, both programming and wiring decisions must be made before the counter can be operated. The following sequence of activities is recommended for applying the 58867-400.

1. Answer the following questions:
 - A. What should each count value represent?
 - B. What should the transistor and relay outputs control or do?
 - C. What should cause each count register to reset?
 - D. What should cause each output turn off (reset input, programmable inputs, output timers, etc.)?
 - E. What units should the rate meter display?
2. Read the Function Code section (pages 6-10) and mark the choices desired. Use the detailed block diagram (page 27) to clarify overall operation and individual function codes.
3. Review the Wiring section (pages 12-16) and layout wiring. Wiring can be affected by Function Code pro-

gramming. Refer to the detailed block diagram (page 27) to clarify wiring.

4. Wire and Program counter as determined in steps 1, 2 and 3 above. **Power must be provided to the counter for programming. Take necessary steps to avoid electric shock.**



PANEL MOUNTING

The panel mounting kit includes:

(1) mounting gasket, (2) mounting clips and (2) screws.

The mounting gasket is coated on one side with a contact adhesive and a paper backing. Care should be taken during the gasket installation that the gasket be correctly positioned on the panel at the first attempt. Attempting to reposition the gasket once the adhesive has come in contact with the panel is likely to deform or tear the gasket. This may result in an improper seal. For best results, follow these directions:

1. Stand the President counter on a desk or table with its display down, screw terminals up.
2. Remove and discard the center square of the gasket at the scribe marks in the gasket and paper backing. Do not remove the backing from the remaining outer rim.
3. Slide the gasket down the unit until it is in position at the rear of the unit's front bezel. The paper backing side should be up.
4. Insert the tip of a knife between the paper and the gasket and, while holding the gasket down to the unit with the knife, peel off the paper backing.
5. Slide the unit through the panel cutout until the gasket firmly adheres to the panel.
6. Install the mounting clips and screws as shown in the diagram above. Do not overtighten the mounting screws. The screws should be tight enough to firmly hold the unit in place, but not so tight as to squeeze the gasket out from behind the front bezel.
7. A switch shall be included in the building installation:
 - It shall be in close proximity to the equipment and within easy reach of the operator.
 - It shall be marked as the disconnecting device for the equipment.
 - Switches and circuit breakers in Europe must comply with IEC 947.

SIMPLIFIED BLOCK DIAGRAM / DIMENSIONED DRAWING

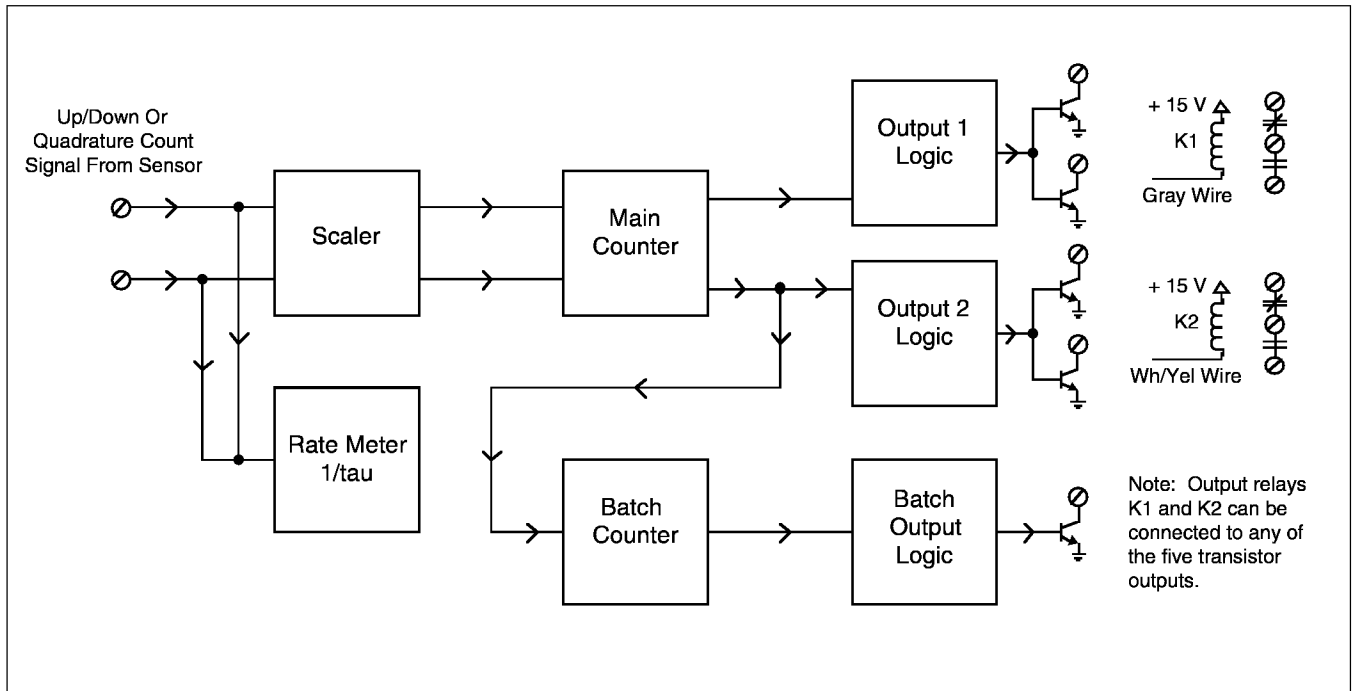

COUNT SCALER

Receives the up or down signals and adds or subtracts the scale factor value to/from the current scaler remainder. The scaler outputs the integer result as up or down pulses to the main counter. The fractional portion of a count remaining is stored in the scaler's memory.

MAIN COUNTER

Counts the up and down pulses from the scaler. The main counter constantly checks if its value has reached either of the preset values (coincidence). For coincidence to occur, the main counter must count up to a preset value. If coincidence occurs, the main counter outputs a signal to the corresponding preset 1 or preset 2 output. The main counter can only be reset to zero. The user can program the unit to operate in a prewarn mode for simulating reset to preset/down counting. The unit also includes an "on the fly" mode so that presets can be entered while the unit is counting without the danger of counting past a new preset.

RELAY AND TRANSISTOR OUTPUT LOGIC

These blocks act like latching relays. When the latch input receives a signal, the output turns on and stays on until it times out or until the unlatch input receives a signal. Output logic can be reversed for failsafe operation.

BATCH COUNTER

Counts up when main counter reaches preset 2. The batch counter constantly checks if its value has reached the batch preset value (coincidence). If coincidence has occurred, the batch counter outputs a signal to the batch output.

RATE METER

The rate meter block measures the time duration of up and/or down pulses into the count scaler. It uses this time measurement along with the user programmed rate scale factor to calculate a rate in meaningful units. The rate meter automatically averages groups of pulses for higher input speeds to provide a convenient rate update time. Internal logic resets the rate meter if no input pulses are received within ten seconds.

PROGRAMMABLE INPUTS

The High Speed President control has four programmable input terminals. Each of these terminals may be programmed for one of eight functions (see page 6, function codes 11 through 14). The reset key also has several user programmable options.

FRONT PANEL FEATURES

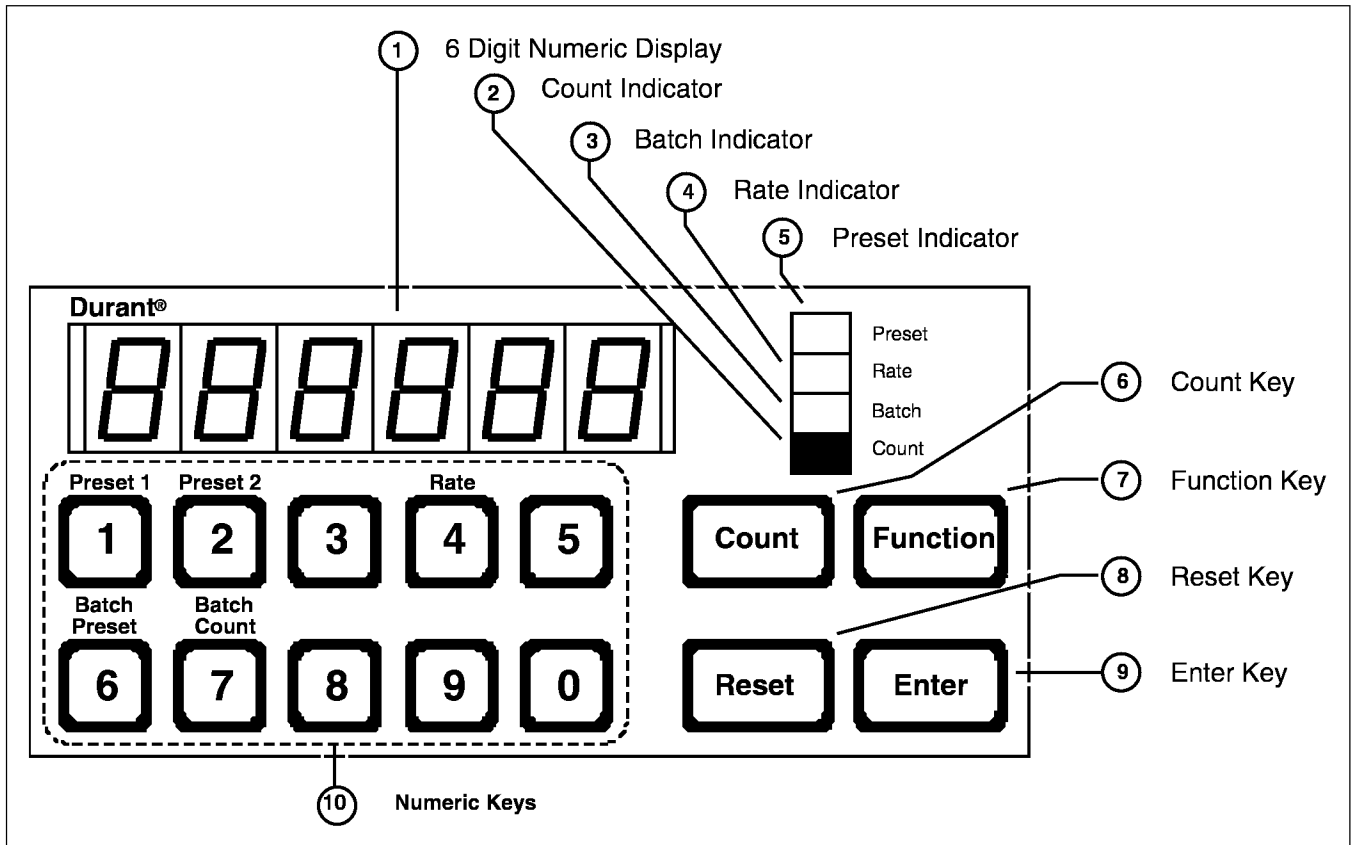

1. **Six (6) digit numeric display** - Displays all numeric values: count values, preset values, rate, and function code numbers and values. The amber LED's on the right indicate which item is being displayed. When all amber LED's are off, a Function Code number or value is being displayed. A decimal point can be lit between any of the 6 digits.
2. **Main Count Indicator** - This amber LED is on whenever the unit is displaying the main count value or one of the main preset.
3. **Batch Count Indicator** - This amber LED is on whenever the unit is displaying the batch count value or the batch preset value.
4. **Rate Indicator** - This amber LED is on whenever the unit is displaying the rate value.
5. **Preset Indicator** - This amber LED is on whenever the unit is displaying a preset value. The count or batch LED also turns on to indicate whether the displayed value is a main counter or batch counter preset.
6. **Count Key** - Press this key to display the current counter value. Press the count key before attempting to display the batch count, rate, or preset values.
7. **Function Key** - Pressing this key causes the display to show "00" and allows you to enter a function code number. This key may be pressed at any time regardless of the current display. Key in a function code number and press the enter key to view the current function code value. You can change the current function code value by keying in a new value and pressing the ENTER key. Press the COUNT key at any time to return to the count display mode. Press the FUNCTION key at any time to select a different function code. (See front panel operation on next page.)
8. **Reset Key** - This key resets the main counter. It may also be programmed to reset the batch counter and/or unlatch any combination of outputs.
9. **Enter Key** - Press this key to enter new preset values that you have keyed in. This key is also used in conjunction with the FUNCTION key to select function codes and enter new function code values.
10. **Numeric Keys** - These keys are used for numeric data entry when programming preset and function code values. Five of these keys have a secondary function printed above them. **Press the count key before accessing any of the secondary functions.**

FRONT PANEL OPERATION

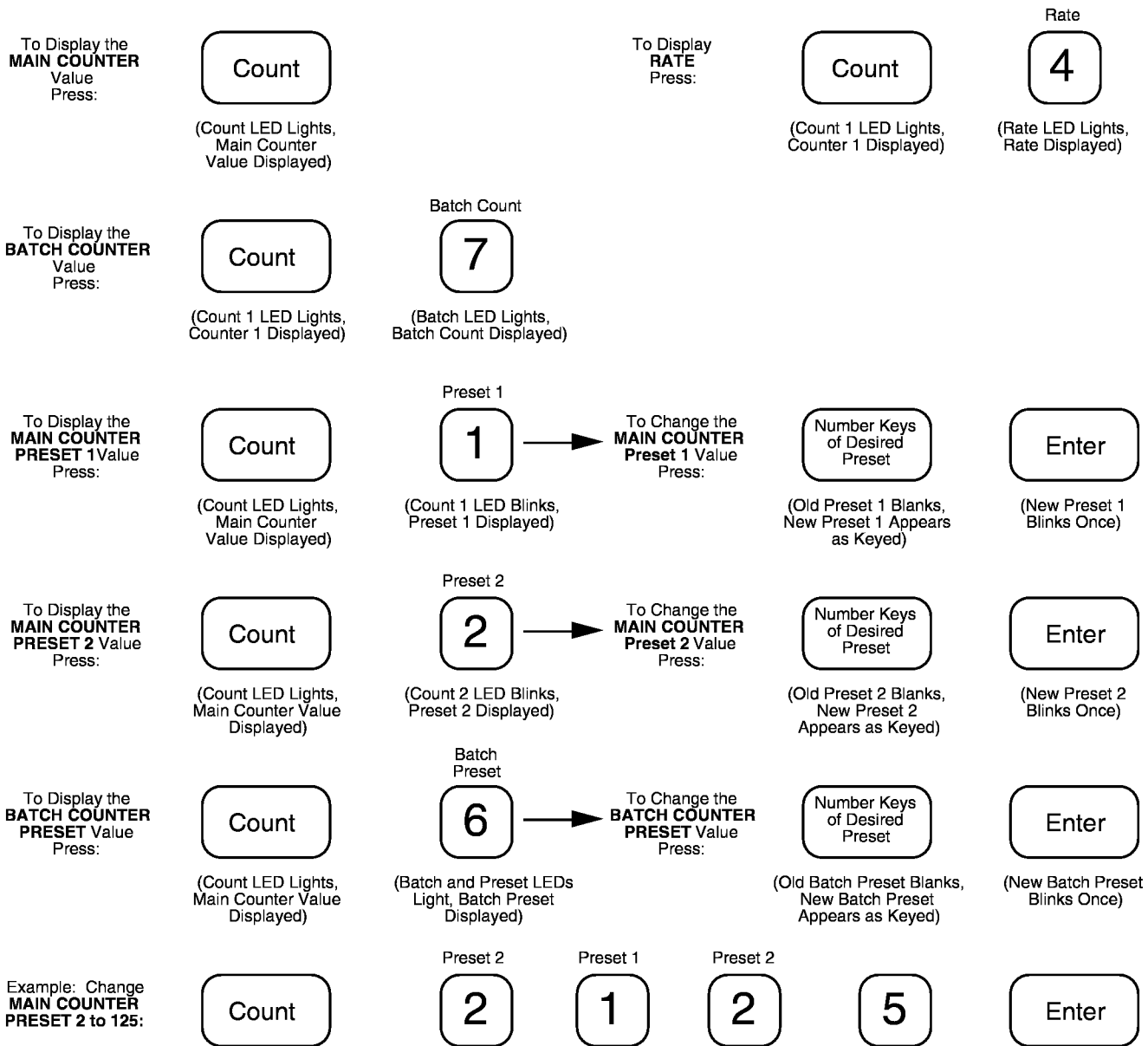

Use the following Key Sequence to display and change Function Code Values:

(Inhibit jumper (programmable) cannot be installed when changing function code values.)

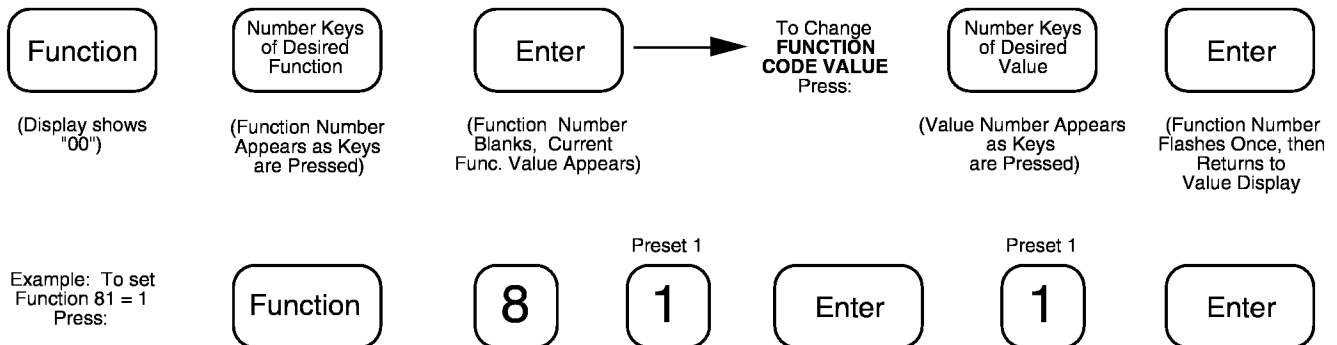

FUNCTION CODE INTRODUCTION AND LIST

Introduction to Function Codes

The versatility of the 58867-400 count control is harnessed through function code programming. Function codes allow the user to easily customize the generic 58867-400 to perform the specific count control tasks required in a wide range of applications. The best way to learn the operating options available is to read through all of the function code descriptions. Adequate information is provided in the description of each function code to allow the appropriate choices to be made. It is recommended that the detailed block diagram be used to aid in visualizing the count/control features available, and how they interrelate.

When power is initially applied to the unit, all function code values will be at the factory default settings. The factory default settings are marked with an * in the function code list section of this manual. In many cases, the factory set values for most of the function codes will be appropriate for the specific application. **TO SIMPLIFY PROGRAMMING USE AS MANY FACTORY SETTINGS AS POSSIBLE.** Only those function codes that require a value other than the factory setting need to be programmed. All function codes can be restored to the factory default values by setting Function 43 = 1.

This counter has a non-volatile memory that retains function code programming, count values, and preset values while power is removed. Once programmed, the unit will never require programming again unless there is a need to alter its operation. Once the function codes are programmed to the desired settings, a program Inhibit jumper can be installed to prevent accidental or unwanted changes (preset values can also be locked with this jumper as determined by function 41)

Overview of Output Operation

The 58867-400 President count control has three sets of digital (on or off) transistor outputs (refer to detailed block diagram). The user may connect each of the two built in relays to any of the transistor outputs. A relay will drop out when the transistor it is connected to turns on. All transistor outputs power up in the off (non-conducting) state regardless of programming or prior condition.

Normally, a transistor output (and any associated relay) turns on when it receives a latch signal and turns off when it receives an unlatch signal. However, any set of transistor outputs may be programmed to operate in reverse. In the reverse mode, a transistor output will still power up in the off state, but it will turn on when it receives an unlatch signal and turn off when it receives a latch signal. For failsafe operation, it is recommended that reverse output logic be used in applications where the counter turns off a machine function (liquid dispensing).

A latch signal is automatically provided to an output whenever that output's preset is reached by the corresponding counter. Consult the detailed block diagram and function code list for information on other latch and unlatch signals.

Function Code Listing

Func 5 - Count Scale Factor: The count scale factor is a user programmable number that determines the count value of each input pulse. It is used to correct for a known amount of error (wheel wear, viscosity, etc.) or to convert the incoming count signal into the desired units of measure on the display (feet, gallons, yards, etc.). The main counter shows whole (integer) counts; the scaler retains fractional counts.

Count scaler range: 0.00100 to 9.99999

Default count scaler: 1.00000

Count Scale Factor (CSF) Formula:

$$\text{CSF} = \frac{\text{DPF}}{\text{PPI}}$$

where:

DPF is the decimal point factor determined by the desired decimal point position on the main counter:

<u>DPF DISPLAY</u>	<u>DPF DISPLAY</u>
1 = XXXXXX	1000 = XXX.XXX
10 = XXXXX.X	10000 = XX.XXXX
100 = XXXX.XX	100000 = X.XXXXX

(Use the main counter decimal point, function 62, to select the desired decimal point position for the main counter.)

PPI is the number of pulses per item from the sensor (times 2 if doubled, times 4 if quadrature x 4 count mode).

Example: An encoder produces 120 pulses per foot. Calculate the count scale factor required to indicate material usage in 1/100s of feet (XXXX.XX).

$$\text{CSF} = \frac{100}{120} = 0.83333$$

(Set function code 62=2 to select the XXXX.XX decimal point position for the main counter display.)

Note: * = default selection.

Func 11 - Terminal 1 Definition (factory default = 5)

Func 12 - Terminal 2 Definition (factory default = 3)

Func 13 - Terminal 3 Definition (factory default = 6)

FUNCTION CODE LIST continued

Func 14 - Terminal 4 Definition (factory default = 9)

Terminals 1 through 4 can each be programmed to perform any one of the following functions:

- 0. No function.
- 1. Unlatch output 1.
- 2. Unlatch output 2.
- 3. Unlatch outputs 1 and 2.
- 4. Unlatch output 3.
- 5. Latch outputs as selected with functions 76 and 77. This mode may be also used to simultaneously reset counters as selected with function 79.
- 6. Reset batch counter.
- 7. Initiate serial transmission.
- 8. Decrement batch counter.
- 9. Program inhibit.

Func 30 - Preset 1 Output Timer: The preset 1 output will latch for this number of seconds before it unlatches.

- 0. No timeout: Preset 1 output will stay latched until an unlatch signal or condition occurs (unlatch input, unlatch at reset, etc.)
- .01-99.99 is the timeout range in seconds.
*10.00 is the factory setting

Func 31 - Preset 2 Output Timer: The preset 2 output will latch for this number of seconds before it unlatches.

- 0. No timeout: Preset 2 output will stay latched until an unlatch signal or condition occurs (unlatch input, unlatch at reset, etc.)
- .01-99.99 is the timeout range in seconds.
*10.00 is the factory setting.

Func 32 - Batch Output Timer: The batch output will latch for this number of seconds before it unlatches.

- 0. No timeout: Batch output will stay latched until an unlatch signal or condition occurs (unlatch input, unlatch at reset, etc.)
- .01-99.99 is the timeout range in seconds.
*10.00 is the Factory Setting.

Func 33 - Reverse Preset 1 and Preset 2 Outputs: Reversed outputs turn off when the preset is reached or a latch signal occurs and turn on when an unlatch signal occurs.

- *0. Preset 1 and preset 2 outputs not reversed.
- 1. Preset 1 output reversed.
- 2. Preset 2 output reversed.
- 3. Preset 1 and preset 2 outputs reversed.

Func 36 - Unlatch Outputs when Reset is Released: Preset 1 and/or preset 2 output(s) can be programmed to unlatch when the reset key or reset input (term 17) is released.

- * 0. No outputs unlatch.
- 1. Preset 1 output unlatches.
- 2. Preset 2 output unlatches.
- 3. Preset 1 and 2 outputs unlatch.

Func 39 - Unlatch Outputs when Reset is Actuated: Preset 1 and/or preset 2 output(s) can be programmed to unlatch when the reset key or reset input (term 17) is actuated.

- * 0. No outputs unlatch.
- 1. Preset 1 output unlatches.
- 2. Preset 2 output unlatches.
- 3. Preset 1 and 2 outputs unlatch.

Func 40 - MANUAL SELF DIAGNOSTICS:

- * 0. Normal operation
- 1. Perform self diagnostics: Control performs self diagnostics in the sequence listed below. Func 40 returns to 0 automatically when diagnostics are completed.
 - Counter displays ROM version # for 1 second.
 - Counter displays 888888 for approximately 1/2 second.
 - Display counts down from 6 to 1 while internal tests are performed:
 - Counter returns function 40 to a value of zero and displays the function code 40 value of zero. If the counter detects a failure, it will flash the failed test number (see diagnostics section of this manual for further information).

Func 41 - PROGRAM INHIBIT JUMPER LOCK-OUT FUNCTIONS: In addition to locking out function code changes, when the programmable inputs (terminals 104) are programmed to a value of 9 they can be programmed to selectively lock-out preset changes, the manual batch output unlatch function, the manual batch reset function, and the manual print function. Program a two digit value as follows:

Tens Digit

- * 0. Enable function codes 70, 71, and 98.
- 1. Disable function code 70.
- 2. Disable function code 71.
- 3. Disable function codes 70 and 71.
- 4. Disable function code 98.
- 5. Disable function codes 70 and 98.
- 6. Disable function codes 71 and 98.
- 7. Disable function codes 70, 71 and 98.

Units Digit

- * 0. Allow all 3 counter presets to be changed.
- 1. Lock counter 1 preset from being changed.
- 2. Lock counter 2 preset from being changed.
- 3. Lock counter 1 and 2 presets from being changed.
- 4. Lock counter 3 preset from being changed.
- 5. Lock counter 1 and 3 presets from being changed.
- 6. Lock counter 2 and 3 presets from being changed.
- 7. Lock all 3 counter presets from being changed.

Func 43 - FACTORY SELECT:

- * 0. Normal operation of counter.
- 1. Set all functions to factory settings (values marked with *). Func 43 automatically returns to 0.

FUNCTION CODE LIST continued

Func 60 - Count Mode: This function code determines how the main counter will respond to count signals on its input terminals (10 and 14).

- 0. Add/subtract. Input 2 (terminal 10) adds counts, input 1 (terminal 14) subtracts counts.
- *1. Quadrature x1. For proper operation, the double input (terminal 18) must be connected to DC Common. This mode requires a quadrature signal input. The count direction depends on the phase relationship on inputs 1 and 2. False counts due to vibration or jitter are eliminated.
- 2. Quadrature x2. This mode is the same as the quadrature x1 mode above except two counts are accumulated per quadrature cycle. This allows increased resolution from a given quadrature pulse source.
- 3. Quadrature x4. This mode is the same as the above quadrature modes except four counts are accumulated per quadrature cycle. This allows a further increase in resolution from a given quadrature pulse source.

Func 62 - Main Counter Decimal Point Position: This function code determines the position of the decimal point on the main counter display. The selected decimal point position is not affected by the count scale factor.

- 0. No decimal point.
- 1. XXXXX.X (display indicates tenths).
- 2. XXXX.XX (display indicates hundredths).
- 3. XXX.XXX (display indicates thousandths).
- 4. XX.XXXX (display indicates ten thousandths).
- 5. X.XXXXX (display indicates hundred thousandths).

Func 63 - Rate Meter Decimal Point Position: This function code determines the position of the decimal point on the rate meter display. The selected decimal point position is not affected by the count scale factor.

- 0. No rate meter decimal point.
- 1. XXXXX.X (display indicates tenths).
- 2. XXXX.XX (display indicates hundredths).
- 3. XXX.XXX (display indicates thousandths).
- 4. XX.XXXX (display indicates ten thousandths).
- 5. X.XXXXX (display indicates hundred thousandths).

Func 64 - Rate Meter Scale Factor: The rate meter scale factor (RSF) is a user programmed number which determines the rate meter value of each input pulse. It is used to convert the count input pulse frequency into the desired units for display (feet/minute, inches/second, boxes/hour, etc.) The rate meter scale factor is entered as a five digit number with an exponent (six digits total). The exponent is the far right digit and is separated from the significant digits by a decimal point.

Rate Scaler Range: 0.0001.0 to 9.9999.4

Default Rate Scaler: 1.0000.0

Rate Scaler (RSF) formula:

$$RSF = \frac{SEC \times DPF}{PPI}$$

where:

SEC is the number of seconds in the rate time unit (items/minutes = 60, items/hour = 3600, etc.).

DPF is the decimal point factor determined by the desired decimal point position on the rate meter:

DPF DISPLAY	DPF DISPLAY
1 = XXXXXX	1000 = XXX.XXX
10 = XXXXX.X	10000 = XX.XXXX
100 = XXXX.XX	100000 = X.XXXXX

(Use function 63 to select the desired decimal point position for the rate meter.)

PPI is the number of pulses per item from the sensor (times 2 if doubled, times 4 if quadrature x 4 count mode).

Example 1: A sensor produces 1 pulse per foot of . Calculate the count scale factor required to indicate material usage in 1/100s of feet (XXXX.XX).

$$RSF = \frac{60 \times 1}{1} = 60 = 6 \times 10^1 = 6.0000.1$$

Example 2: A flow sensor produces 432 pulses per gallon. Display flow rate in tenths of a gallon per minute (XXXX.X).

$$RSF = \frac{60 \times 10}{432} = 1.3889 = 1.3889 \times 10^0 = 1.3889.0$$

(Set function 63 to 1 to select the XXXXX.X position on the rate display.)

Func 70- Reset Batch Counter: The batch output can be manually unlatched from the keyboard without affecting the main counter.

- *0. Normal state.
- 1. Batch output unlatches - function 71 returns to 0.

FUNCTION CODE LIST continued

Func 72- Reverse Batch Counter: Reversed outputs turn off when the preset is reached or a latch signal occurs and turn on when an unlatch signal occurs.

- *0. Batch output not reversed.
- 1. Batch output reversed.

Func 73- Unlatch Batch Output when Reset is Released: The batch output can be programmed to unlatch when the reset key or reset input (term 17) is released.

- *0. Batch output does not unlatch with reset.
- 1. Batch output unlatches when reset is released (74 must be programmed to 1).

Func 74 - Reset Batch Counter with Reset Signal: The batch counter can be programmed to reset when the reset key or reset input is actuated.

- *0. Batch counter does not reset with the reset key or input.
- 1. Batch counter resets when reset key or input is actuated.

Func 75 - Unlatch Batch Output when Reset is Actuated: The batch output can be programmed to unlatch when the reset key or reset input (term 17) is actuated.

- *0. Batch output does not unlatch with reset.
- 1. Batch output unlatches when reset is actuated (74 must be programmed to 1).

Func 76 - Latch Batch Output with External Signal: The batch output can be programmed to latch when an external input is actuated. One of the four programmable inputs must be programmed as an output latch (functions 11, 12, 13, or 14 = 5).

- *0. Batch output does not latch with external signal.
- 1. Batch output latches when an output latch is actuated.

Func 77 - Latch Preset 1 and/or Preset 2 Output with External Signal: Preset 1 and/or preset 2 outputs can be programmed to latch when an external input is actuated. One of the four programmable inputs must be programmed as an output latch (functions 11, 12, 13, or 14 = 5).

- *0. Preset 1 and preset 2 outputs do not latch with external signal.
- 1. Preset 1 output latches when an output latch input is actuated.
- 2. Preset 2 output latches when an output latch input is actuated.
- 3. Preset 1 and preset 2 outputs latch when an output latch input is actuated.

Func 79 - Reset Counter with an Output Latch Signal: The main counter and/or batch counter can be programmed to reset when an output latch signal occurs. One of the four programmable inputs must be programmed as an output latch (functions 11, 12, 13, or 14 = 5) and functions 76 or 77 must be set to latch the corresponding counter's output. The main

counter can only be programmed to reset when the preset 2 output is latched.

- *0. No reset when outputs are latched.
- 1. Reset main counter with preset 2 output latch signal.
- 2. Reset batch counter with preset 2 output latch signal.
- 3. Reset both the main counter and batch counter if both preset 2 output and batch output are latched with an external signal.

Func 80 - Preset 1 Prewarn/Normal Mode: This function code determines the operation of the preset 1 output. The prewarn mode is used to simulate dual preset count down operation.

- *0. Preset one output occurs when the main counter counts up to the preset 1 value.
- 1. Preset 1 output occurs when the main counter counts up to the value of preset 2 minus preset 1 (preset 2 - preset 1). For proper operation, preset 2 must be greater than preset 1.

Func 81 - Main Counter Auto-Recycle: The main counter may be programmed to automatically reset when the preset 2 value is reached.

- *0. No auto-recycle.
- 1. Main counter auto-recycles when it reaches preset 2.

Func 82 - Reset Input Mode: The reset input and reset key may be programmed to operate in a maintained or momentary mode. In the maintained mode, all reset and unlatch functions associated with a reset signal will be in effect as long as the reset signal is applied. In the momentary mode, the functions associated with a reset signal will take effect only when the signal is first applied.

- *0. Maintained reset mode
- 1. Momentary reset mode.

Func 83 - Preset Load Mode: The user can select between two preset load modes. In the non-buffered mode, new preset values become effective immediately when the enter key is pressed. In the buffered mode, new preset values do not become effective until an auto-recycle or reset signal occurs. The buffered mode is used to prevent the operator from accidentally entering a preset value which is smaller than the current count value.

- *0. Non-buffered preset mode. Presets take effect when enter key is pressed.
- 1. Buffered preset mode. Presets take effect when an auto-recycle or reset signal occurs.

Func 84 - Batch Auto-Recycle: The batch counter can be programmed to automatically reset when it reaches the batch preset value.

- *0. No batch auto-recycle.
- 1. Batch counter auto-recycles when it reaches the batch preset.

FUNCTION CODE LIST continued

Func 90 - Communication Speed (Baud Rate): The baud rate is the number of data bits per second sent and received by the counter's communication port. Baud rates between transmitting and receiving devices must be the same.

- *0. 110 baud.
- 1. 300 baud.
- *2. 1200 baud.

Func 91 - Data Transmission Select: This function code determines which values are sent when the unit is using the standard President Communications format (func 93 = 0), and a print request (serial, reset, or programmable terminal is received). This function code does not apply if the enhanced communications format is selected. Enter a three digit number as follows:

Hundreds Digit

- *0. Transmit batch count, batch preset, and rate.
 - 1. Transmit batch preset and rate.
 - 2. Transmit batch count and rate.
 - 3. Transmit rate.
 - 4. Transmit batch count and batch preset.
 - 5. Transmit batch preset.
 - 6. Transmit batch count.
 - 7. Do not transmit batch count, batch preset, or rate.

Tens Digit

- *0. Transmit main count, preset 1, and preset 2.
 - 1. Transmit preset 1 and preset 2.
 - 2. Transmit main count and preset 2.
 - 3. Transmit preset 2.
 - 4. Transmit main count and preset 1.
 - 5. Transmit preset 1.
 - 6. Transmit main count.
 - 7. Do not transmit main count, preset 1, or preset 2.

Units Digit

- *0. Transmit scale factor and rate multiplier.
 - 1. Transmit rate multiplier.
 - 2. Transmit scale factor.
 - 3. Do not transmit scale factor or rate multiplier.

Func 92 - Transmit on Reset: The control can be programmed to transmit the values programmed in function 91 above when reset signal (key or input) is actuated.

- *0. No transmit on reset.
 - 1. Transmit on reset.

Func 93 - Communications Format: Two communications formats are available - the standard President series format (see page 18) and an enhanced format (see page 19).

- *0. Standard President format.
 - 1. Enhanced format.

Func 94 - Unit ID Number: This function code determines the serial ID number of the unit. The enhanced communications format (function 93 = 1) requires the host computer or other communicating device to transmit an ID number with each President command.

*0 - 99 is the ID number of the unit.

Func 95 - Parity Select: This function code determines the type of parity that is transmitted and received by the unit. Any received commands that do not match the selected parity type will be ignored by the unit.

- *0. Space parity transmitted. Ignore received parity bit.
 - 1. Odd parity transmitted and received.
 - *2. Even parity transmitted and received.

Func 96 - Communication Lock: The unit can be programmed to ignore certain serial commands. The communication lock is valid only when the control is using the enhanced communication format (function 93 = 1). Enter a two digit number as follows:

Tens Digit

- *0. No lock on function code or output control commands.
 - 1. Lock function code programming commands.
 - 2. Lock output control commands.
 - 3. Lock both function code and output control commands.

Units Digit

- *0. No lock on count reset commands.
 - 1. Lock main counter reset command.
 - 2. Lock batch counter reset command.
 - 3. Lock main and batch counter reset command.

Func 98 - Transmit Command: The user can manually cause the control to transmit the values selected in function code 91.

- *0. Normal state.
 - 1. Transmit values specified in function code 91 - function code 98 returns to 0.

TERMINAL DESCRIPTIONS AND WIRING

General Wiring Practices

1.  Disconnect all power before wiring terminals. **A safety hazard exists if this precaution is not observed. Treat all control and count inputs as hazardous because they may carry line voltage.**
2. Use shielded cables for Count signals. Connect shield to terminal 32 of Counter.
3. Keep all signal lines as short as possible.
4. Do NOT bundle or route signal lines with power or machine control wiring.
5. Provide "Clean" power to the Counter. In severe cases power may have to be filtered or a separate power source used.
6. Wire an RC Suppressor in parallel with all inductive loads (solenoids, relay coils, etc.) controlled by external Counter. Use Durant Pt# 38091-400 or equivalent.
7. Use 18 ga. minimum (1mm², 600V) and 14 ga. maximum (1.6mm², 600V) wire for AC power wiring.
8. See page 11, second column, for correct fuse to be used in the power input wiring.

Back Panel Layout

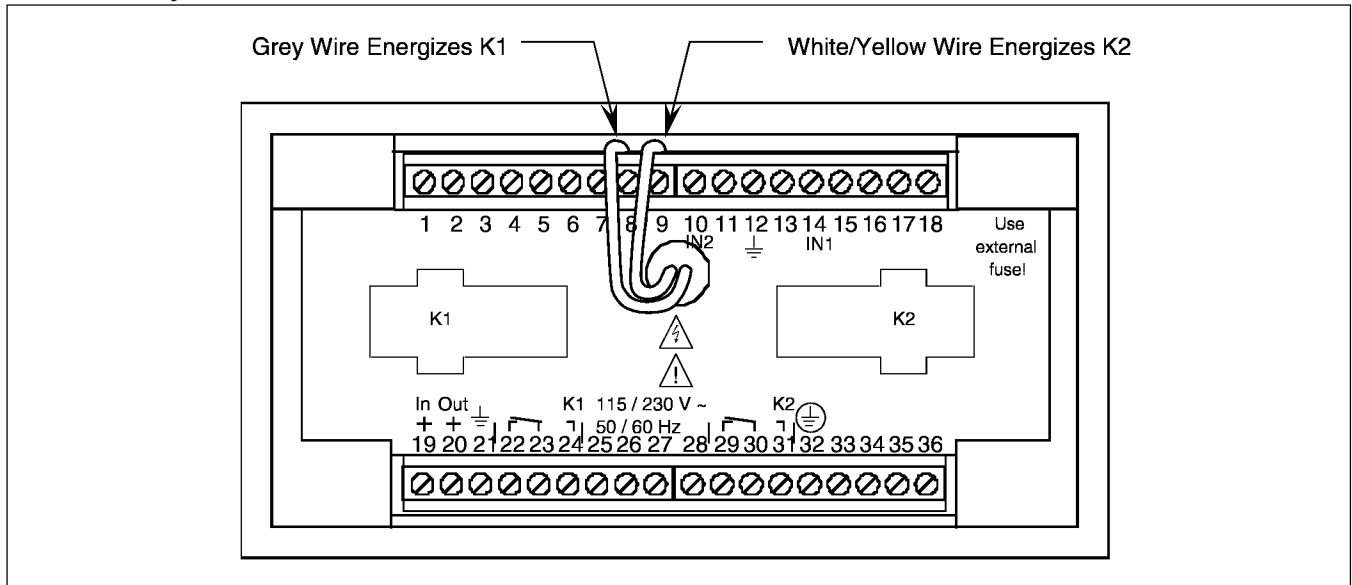

Terminal Identification and Function

1, 2, 3, 4 - Programmable Inputs: You may select one of eight functions for each of these inputs (see function codes 11 through 14).

5, 8 - Preset 1 Transistor Outputs: Each of these terminals is connected to a separate open collector NPN transistor. The transistors normally turn on when the main counter reaches preset 1 or preset 2 minus preset 1 depending on function code 80. The outputs can also be turned on when an external latch signal occurs. The transistors normally turn off when timed out or when an external unlatch signal occurs. You can program the outputs to operate in reverse so that a latch signal turns them off and an unlatch signal turns them on. The grey and/or yellow/white wire may be connected to either terminal to provide normally open and normally closed relay contact outputs on the K1 and/or K2 terminals.

6, 9 - Preset 2 Transistor Outputs: Each of these terminals is connected to a separate open collector NPN transis-

tor. The transistors normally turn on when the main counter reaches preset 2 or when an external latch signal occurs. The transistors normally turn off when timed out or when an external unlatch signal occurs. The outputs can be programmed to operate in reverse so that a latch signal turns them off and an unlatch signal turns them on. The grey and/or yellow/white wire may be connected to either terminal to provide normally open and normally closed relay contact outputs on the K1 and/or K2 terminals.

7 - TRANSISTOR OUTPUT: This terminal is connected to an open collector NPN transistor. The transistor normally turns on when the batch counter reaches its preset or when an external latch signal occurs. The transistor normally turns off when timed out or when an external unlatch signal occurs. You can program the output to operate in reverse so that a latch signal turns it off and an unlatch signal turns it on. The grey and/or yellow/white wire may be connected to this terminal to provide normally open and normally closed relay contact outputs on the K1 and K2 terminals.

TERMINAL DESCRIPTIONS AND WIRING continued

10, 14 - Count Inputs 2 and 1: Connect the count input signal(s) to these terminals. If the separate add/subtract count mode is used, input 2 (terminal 10) adds counts and input 1 (terminal 14) subtracts counts. You must connect both terminals if you are using any of the quadrature count modes.

11, 13 - Low Frequency Select - Count Inputs 2 and 1: When connected to DC Common, these inputs reduce the frequency response of the corresponding count input to 150 Hz. Make this connection whenever possible to provide additional count input noise immunity or to eliminate false counts due to mechanical contact bounce.

12, 21 - DC Common: These terminals are connected to the negative side of the counter's internal DC power supply. Count inputs must be referenced to DC Common. Programmable inputs are on when connected to DC Common. Transistor outputs conduct to DC Common when turned on. The 15 VDC output is also referenced to DC Common.

15, 16 - Do Not Use: These terminals are not used by this model; however, they are connected to the counter's internal circuitry. Do not use these terminals as wiring junction points.

17 - Reset Input: This input and the front panel reset key are in parallel and can be used interchangeably. The main counter is reset when this input is switched to DC Common. You can program the batch counter to also reset from this signal (func. 74) and program any combination of outputs to unlatch from this signal (func 36, 39, 73, and 75). You can program the reset input and key for maintained or momentary operation (func 82).

18 - Double Input: When this input is connected to DC Common and the counter is in the add/subtract mode (func 60 = 0), the main counter will count on both the rising and falling edge of both the up or down count signal. This input MUST be connected to DC Common for all quadrature count modes (func 60 = 1, 2, or 3).

19 - DC Power Input: The counter can be powered by DC voltages between 11 and 16 volts (0.7 amp max). Wire the positive power input lead to terminal 19 and the negative lead to DC Common.

20 - +15 VDC Power Output: This terminal can be used to supply 15 VDC (+1V, -2V, 100 mA max) for operating accessories. DC Common is the negative side of this power supply. 15 VDC is not available when counter is DC powered.

22, 23, 24* - K1 Relay Contacts

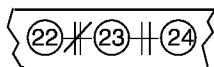

25, 26, 27, 28 - 115/230 VAC Power Input Terminals: The counter can be wired to operate from either 115 or 230 VAC (+10%, -20%, 47-63 Hz).

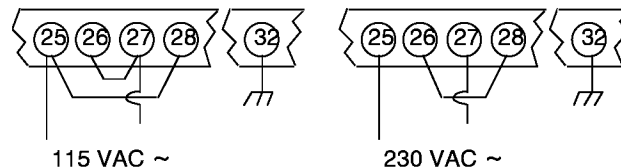

***Fuse:**

	<u>U.S.</u>		<u>European</u>
2/10 amp @ 115 VAC	—	—	T250 mA, 250 V
1/10 amp @ 230 VAC	—	—	T250 mA, 250 V

Note: See page 10, No. 7 on top of page for wire specs.

29, 30, 31* - K2 Relay Contacts



32 - Chassis Ground: This terminal **MUST** be connected to a good electrical ground. The shields of shielded signal cables should be connected to the counter at this terminal.

33 - Serial Data Input Minus (SDI-): Connect this terminal to the SDO+ terminal of the device sending data to the counter.

34 - Serial Data Input Plus (SDI+): Connect this terminal to the SDO- terminal of the device sending data to the counter.

35 - Serial Data Input Plus (SDO+): Connect this terminal to the SDI- terminal of the device receiving data from the counter.

36 - Serial Data Output Minus (SDO-): Connect this terminal to the SDI+ terminal of the device receiving data from the counter.

*** Note:** The K1 and K2 form "C" relay contacts are isolated. You must provide power to any circuit that uses the relay contacts.

COUNT WIRING: CONTACTS/CURRENT SINKING SENSORS

Contact Closure Count Source

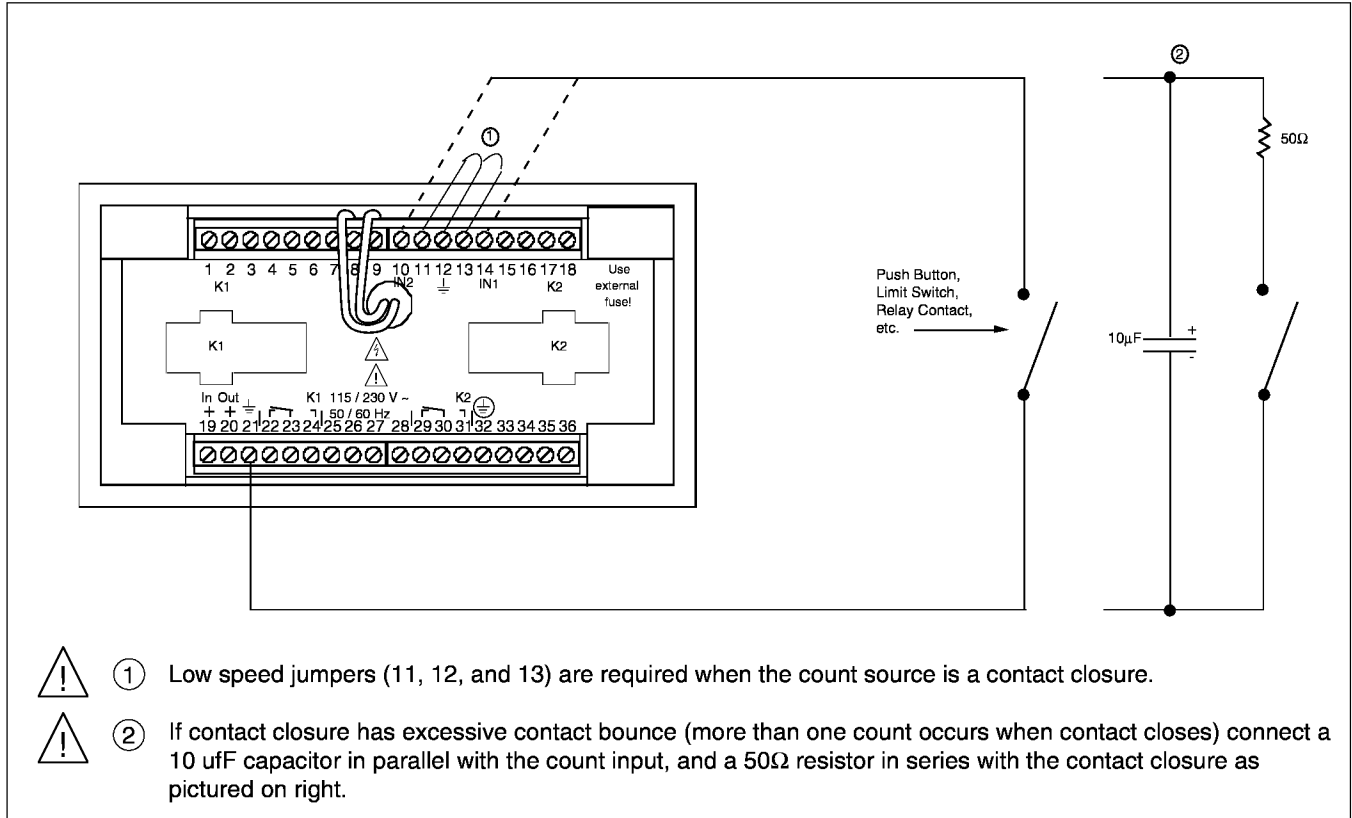

Current Sinking Sensor Count Source

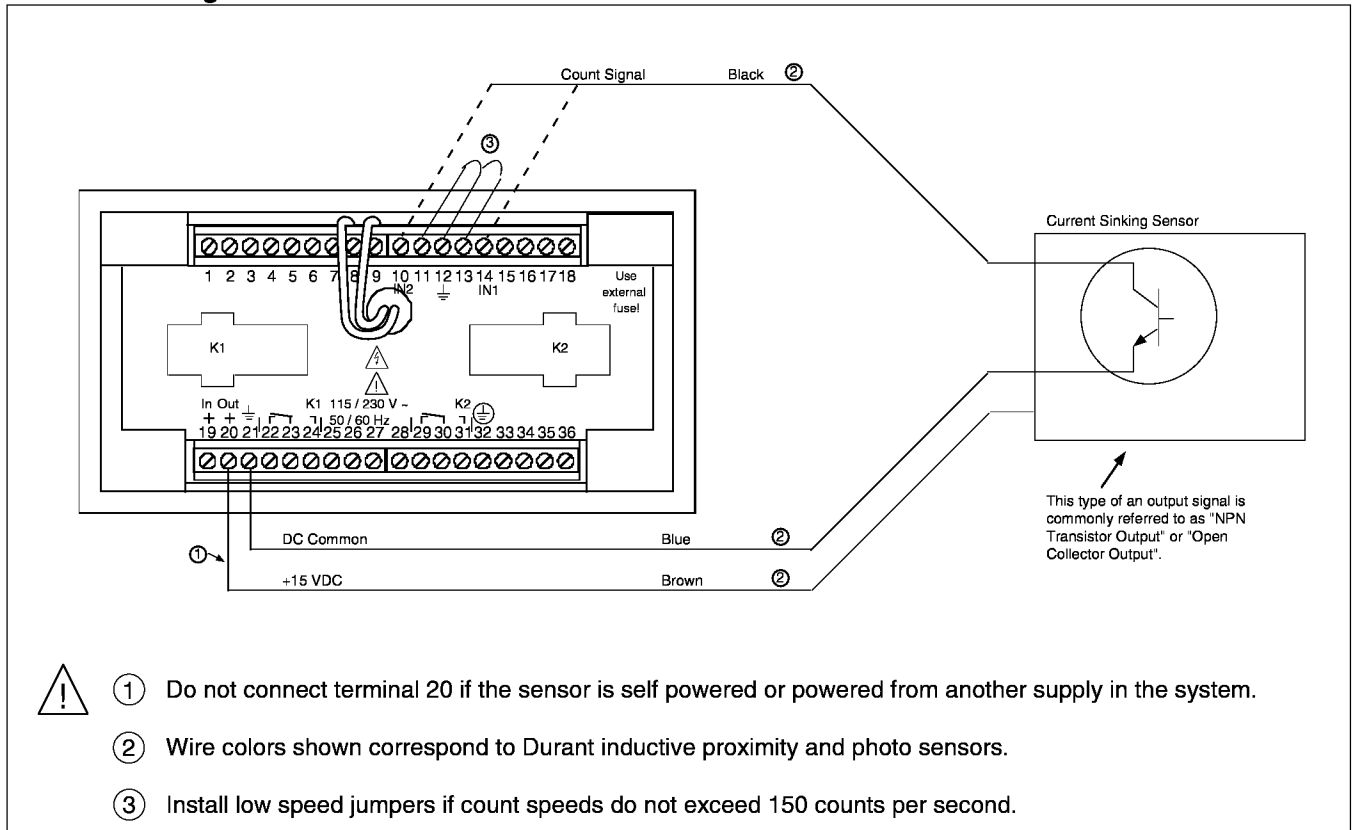

SHAFT ENCODER WIRING: SINGLE CHANNEL/QUADRATURE

Single Channel Shaft Encoder

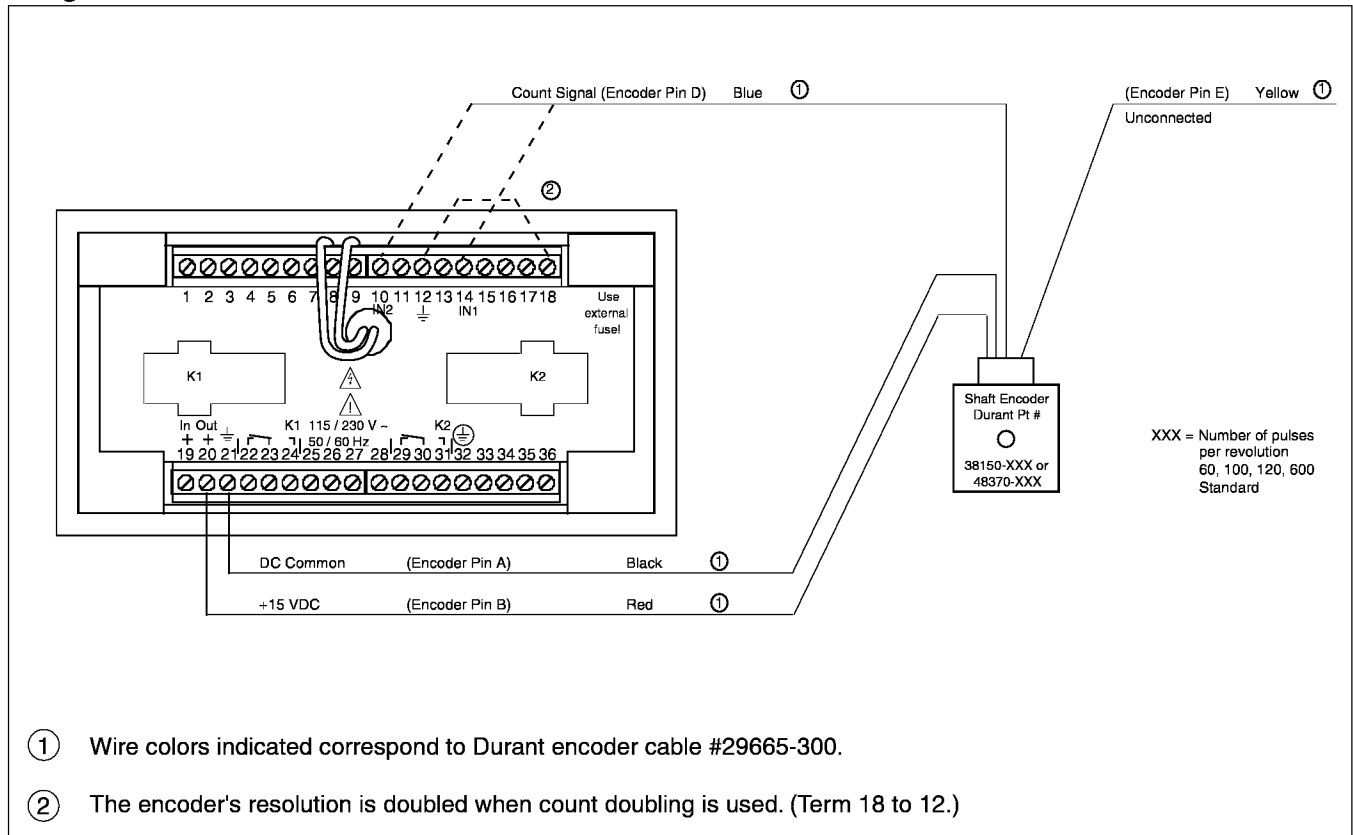

Quadrature Shaft Encoder Wiring

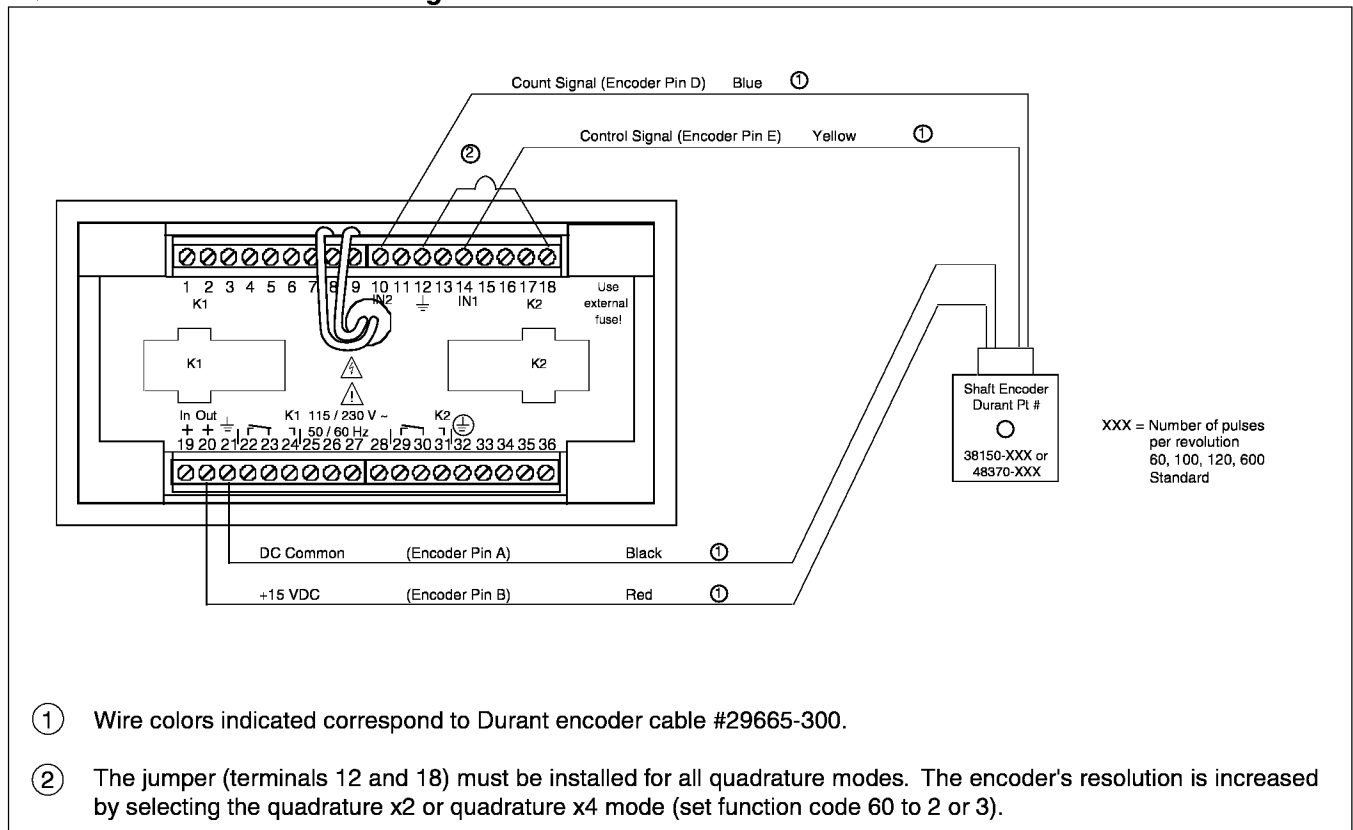

OUTPUT WIRING: RELAY CONTACTS/TRANSISTOR OUTPUTS

Wiring Loads to Relay Contacts

Grey Wire Energizes K1

White/Yellow Wire Energizes K2

①

②

③ R-C Suppressor

AC or DC Power Source for Load (230 Volts Max.)

Load

Use external fuse!

1 2 3 4 5 6 7 8 9 10 11 12 13 14 15 16 17 18

K1 IN2 K2

K1

K2

In Out

K1 115 / 230 V -

50 / 60 Hz

K2

19 20 21 22 23 24 25 26 27 28 29 30 31 32 33 34 35 36

- ① Connect the K1 and K2 wires (grey and white/yellow) to the appropriate transistor output.
- ② This wiring example shows the load being controlled from the normally open contacts of K2. Wiring for the normally closed contacts (29, 30) would be done in the same manner. Wiring for the K1 relay contacts (terminals 22, 23, 24) is also done in the same manner.
- ③ Connect an RC suppressor (Durant part #38091-400) in parallel to all inductive loads. A suppressor can be made with a .22 μ F (400 VAC min) capacitor and a 150 Ω - 1/2 Watt resistor.

Wiring DC Loads to Transistor Outputs

②

① Load

DC Power for Load
30 VDC, 300mA
maximum.

③

1 2 3 4 5 6 7 8 9 10 11 12 13 14 15 16 17 18

K1 IN2 K2

K1

K2

In Out

K1 115 / 230 V -

50 / 60 Hz

K2

19 20 21 22 23 24 25 26 27 28 29 30 31 32 33 34 35 36

- ① The load must not draw more than 300 mA of current. Transistor outputs are internally protected and do not require inductive load suppression.
- ② This example shows the load connected to one of preset 2's transistor outputs. It could be wired to any of the transistor outputs (terminals 5, 6, 7, 8, and 9) in exactly the same manner.
- ③ The counter's internal DC supply can be used to power DC loads. The total current drawn from terminal 20 cannot exceed 100 mA.

CONTROL INPUT WIRING

Wiring Contact Closure to Control Inputs

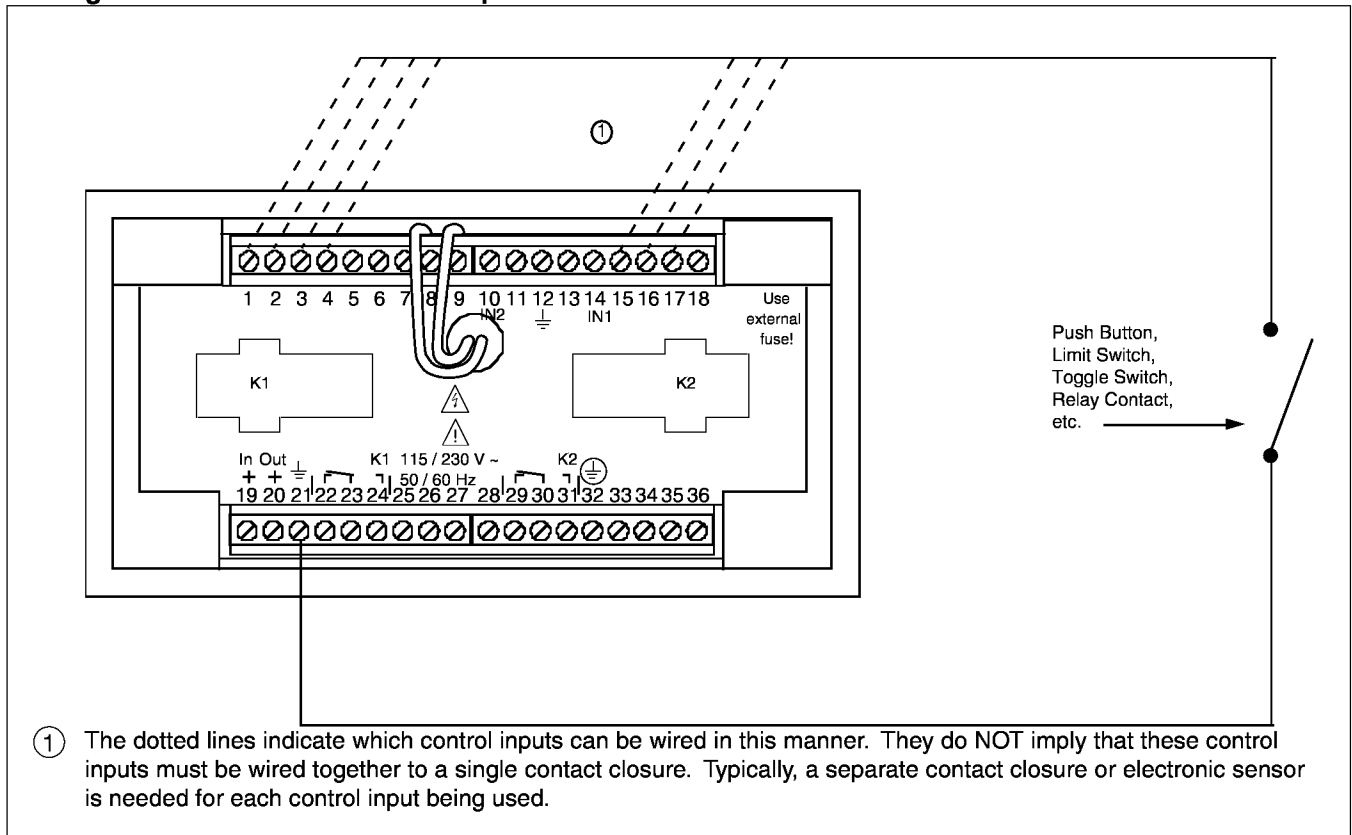

Wiring Current Sinking Sensors to Control Inputs

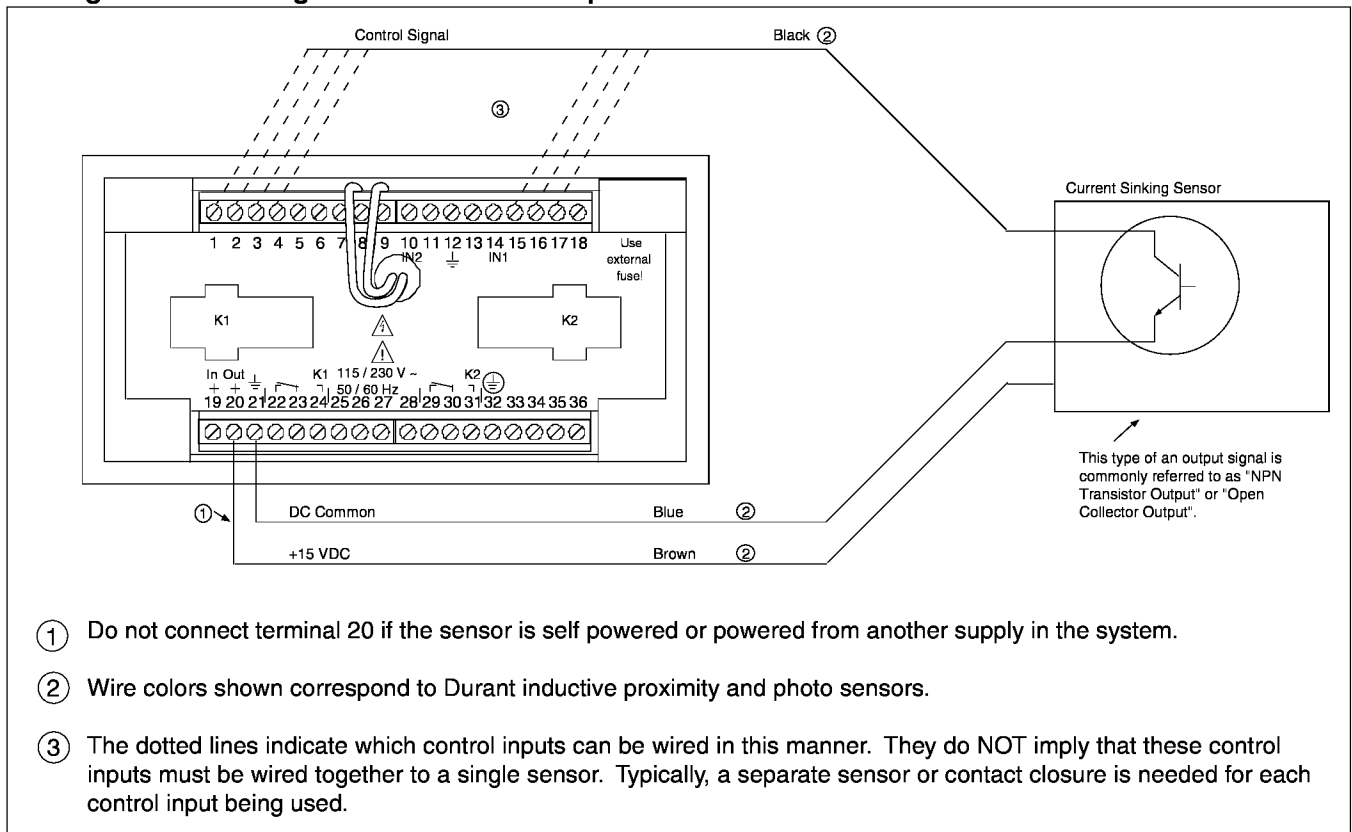

SIMPLIFIED I/O SCHEMATICS

TRANSISTOR OUTPUTS

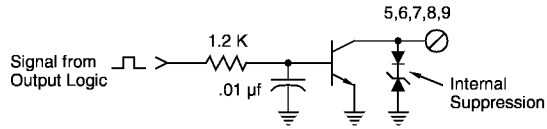

COUNT INPUTS

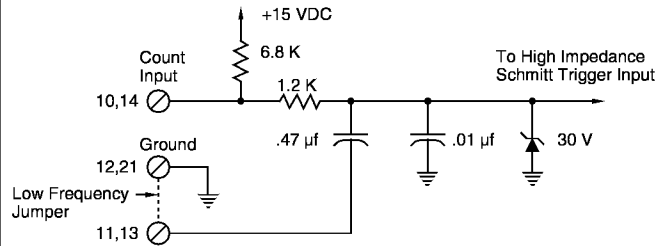

20 mA COMMUNICATION INPUT

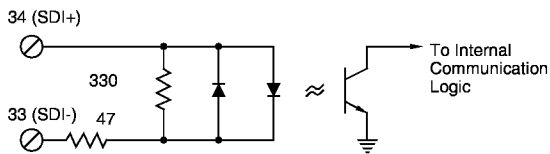

CONTROL INPUTS

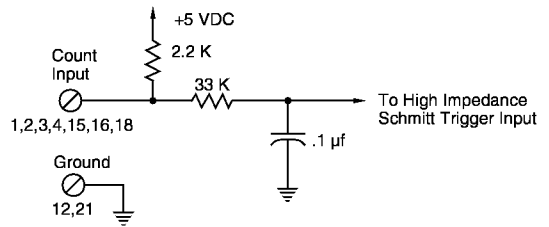

20 mA COMMUNICATION OUTPUT

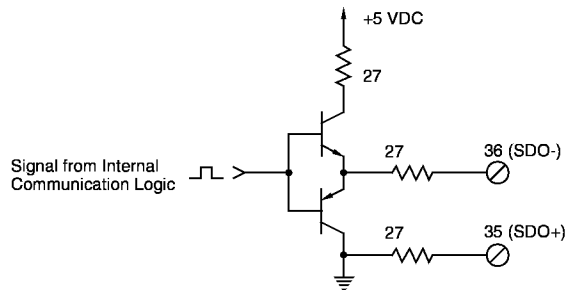

RESET INPUT

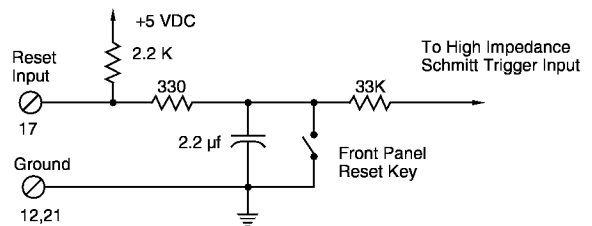

SERIAL COMMUNICATION: OVERVIEW/STANDARD FORMAT

Communication Overview

General - The 58867-400 is able to communicate with computers, printers, PLCs and other devices which have serial communication ports. The unit may operate in one of two different communication formats - the standard President format or an enhanced format. You may select the desired format with function code 93.

Interface - The counter uses ASCII code and a 20 mA current loop interface to allow transmission distances of up to 2000 feet over shielded, twisted pair cables. Durant accessories are available for converting the 20 mA communication signals to RS-232 and parallel BCD.

Character Format - Each ASCII character is composed of seven data bits and one parity bit. You may program the counter to send and receive even, odd, or space parity (see function code 95).

Communication Speed - The counter can communicate at 110, 300 or 1200 baud as selected by function code 90. The baud rate of the counter and the device it is communicating with MUST be the same.

No Handshaking - The counter transmits the items selected in a continuous burst. No handshaking signals are used. The receiving device must be able to buffer the data. Printers that receive data directly from the counter must have a multi-line buffer.

No Decimal Points Received by Counter - The counter automatically inserts decimal points into values received via the communication port. The counter ignores any decimal points that it receives. Function code 62 determines the decimal point position of the main counter and presets. The batch preset does not have a decimal point. The count and rate scaler decimal point positions are fixed.

Decimal Points Sent by Counter - Decimal points are transmitted by the counter in the same position that they are shown on the display.

Invalid Characters - Too Many Characters - Unlike other President series count/controls, the High Speed President does not recognize a transmission that contains invalid or extra characters. If the unit is operating in the standard format and receives an invalid or extra character, it will ignore the command. If the unit is operating in the enhanced format and receives an invalid or extra character, it will ignore the command and respond with an error code 01.

Standard President Format

The standard President communication format (function 93 = 0) allows a host computer to retrieve count, preset, rate, scale factor, and rate meter factor values. The host computer may also send preset, scale factor, and rate meter factor values.

Data Item	Transmitted from Counter	Received by Counter
Main Counter	CNT XXXXXX<cr><lf>	
Preset 1	PS1 XXXXXX<cr><lf>	AXXXXXX*
Preset 2	PS2 XXXXXX<cr><lf>	BXXXXXX*
Batch Counter	BTC XXXXXX<cr><lf>	
Batch Preset	PS3 XXXXXX<cr><lf>	CXXXXXX*
Rate	RTE XXXXXX<cr><lf>	
Scale Factor	SCA X.XXXXX<cr><lf>	SXXXXX*
Rate Multiplier	RML X.XXXXX<cr><lf>	RXXXXX*
Transmission Request		?

Transmission Requests - The counter transmits information when it receives an ASCII "?" (question mark) at the incoming 20 mA port or when the print request input (Term 16) is energized.

Data Items Transmitted - The counter transmits the same group of items each time a transmission occurs. Function 91 determines which items the control sends.

Carriage Returns and Line Feeds - A carriage return (<cr>) and a line feed (<lf>) are always sent ahead of the first item when the counter begins transmitting. Each item transmitted by the counter is followed by a carriage return and a line feed.

ENHANCED COMMUNICATION FORMAT

Enhanced Format

In addition to the functions provided by the standard President communication format, the enhanced format (function code 93 = 1) allows a host computer to send and receive function code values, reset counters, turn outputs on and off, and read specific counter and preset values. The enhanced format uses an Opto-22 compatible protocol.

Serial Command Summary

LP1:	Load Preset 1
LP2:	Load Preset 2
LPB:	Load Batch Preset
Lxxn:	Load Function Code xx with value n
RSM:	Reset Main Counter
RSB:	Reset Batch Counter
TN1:	Turn On Output 1
TN2:	Turn On Output 2
TN3:	Turn On Batch Output
TF1:	Turn Off Output 1
TF2:	Turn Off Output 2
TF3:	Turn Off Batch Output
QMC:	Query Main Counter
QBC:	Query Batch Counter
QRT:	Query Rate
QP1:	Query Preset 1
QP2:	Query Preset 2
QPB:	Query Batch Preset
QAD:	Query All Run Data
QMD:	Query Menu Data
QAP:	Query All Function Codes
Qxx:	Query Function Code xx
RVD:	Read Device Version

Serial Command Summary

The general command format is shown below. Spaces are used for clarity only and must not be transmitted.

> ID# Command [numeric data] Checksum <cr>

Example:

To load a new value of 99 into preset 1 of unit ID# 10, send the LP1 command as follows:

>	10	LP1	99	A0	<cr>
1	2	3	4	5	6

1. Message start character (ASCII 62). Required for all transmissions to the control.
2. Two digit unit ID# (function 94). Required for all transmissions to the control.

3. LP1 (load preset 1) command. All serial commands consist of three characters. Letters may be upper or lower case.
4. Numeric data required with LP1 command. Up to six numeric characters are required with the load preset commands. Note that leading zeros do not need to be sent.
5. Two digit hexadecimal checksum of the ASCII values of the ID number, command, and any required numeric characters. Required for all transmissions to the control.

Checksum calculation:

1	0	L	P	1	9	9
---	---	---	---	---	---	---

$$49 + 48 + 76 + 80 + 49 + 57 + 57 = 416 \text{ (dec.)}$$

$$= 1A0 \text{ (hex.)}$$

The checksum is the last two hexadecimal characters - A0. Upper or lower case letters may be used. The start character and carriage return are not used in the calculation.

6. ASCII carriage return (13 decimal). Required at the end of all commands.

Serial Response Format

The counter does not respond to a command unless the transmitted ID number matches its programmed ID number.

If the ID numbers match and the command and checksum are valid, the control executes the command and transmits a response as shown below:

A [unit ID] [data] [checksum] <cr>

where:

- A is the acknowledge character (ASCII 65) sent when any valid command is received and executed.
- [unit ID] is the user programmed ID number (function 94). The unit ID is sent for the RDV command and all query commands except Qxx. With the query commands, the format is UN xx where xx is the unit ID number (see RDV command for its response format). In the special case of a Qxx command, the control replaces the unit ID with the requested function code number Fxx.
- [data] is sent in response to a query or RDV command. With the query commands, the requested data is preceded by a two or three character counter, preset, or function code identifier.
- [checksum] is sent only for valid commands that request data (query or RDV commands). The checksum is calculated by adding the ASCII values of all preceding characters excluding the acknowledge character.
- <cr> is the carriage return character (ASCII 13).

ENHANCED COMMUNICATION FORMAT continued

Examples:

A<cr> No data requested.
AUN11 CT 0.0 AA<cr> Main count data requested.
AF60 0 1C<cr> Function code 60 setting requested.

If the ID numbers match but the command is not valid or cannot be executed, the counter ignores the command and responds by sending an ASCII "N" (not acknowledged) followed by a two character error code and a carriage return.

Error codes:

- 01 - Invalid command - syntax error.
- 02 - Checksum error - received checksum does not match calculated checksum.
- 07 - Invalid data - an attempt was made to load a function code with an invalid number.
- 10 - Invalid command - communication lock (function 96) is on.

Examples: N01<cr> Invalid command.
N10<cr> Communication lock is on.

Serial Commands

LP1 - Load Preset 1
LP2 - Load Preset 2
LPB - Load Batch Preset

The load preset commands allow a host computer to enter new preset values into the unit. The command must be followed by a one to six digit number. The host does not need to send leading zeros.

Example Command: >00LP11234F7<cr> Sets unit 0's preset 1 to a value of 1234.

Lxxn - Load Function Code xx with value n.

This command allows a host computer to remotely program the unit. The host must send the two digit function code number (function 5 = 05) followed by a one to six digit function code value. The host does not need to send leading zeros.

Example Command: >00L60345<cr> Sets unit 0's function code 60 to a value of 3.

RSM - Reset Main Counter
RSB - Reset Batch Counter

The serial reset commands work the same as the reset key and reset input. Any outputs that are programmed to unlatch with the reset key or input will also respond to the serial reset commands.

Example Command: >00RSM52<cr> Resets the main counter on unit 0.

TN1 - Turn On Output 1
TN2 - Turn On Output 2
TN3 - Turn On Batch Output

These commands allow a host computer to turn on any of the control's outputs. The output will remain on for the programmed time period. If the output is reversed or if time out is disabled, it will turn on and stay on.

Example Command: >00TN234<cr> Turns on output 2 on unit 0.

TF1 - Turn Off Output 1
TF2 - Turn Off Output 2
TF3 - Turn Off Batch Output

These commands allow a host computer to turn off any of the control's outputs. If the output is reversed, it will turn off for the programmed time period.

Example Command: >00TF22C<cr> Turns off output 2 on unit 0.

QMC - Query Main Counter
QBC - Query Batch Counter
QRT - Query Rate
QP1 - Query Preset 1
QP2 - Query Preset 2
QPB - Query Batch Preset

These commands allow a host computer to read the value of the rate meter, any counter, or any preset. The unit precedes each value with the unit ID number and a two character identifier.

ENHANCED COMMUNICATION FORMAT continued

Example Command: >00QMC41<cr> Query unit 0's main counter.

Example Responses:

```
AUN 00 CT 1.02 DB<cr>      (Main counter = 1.02)
AUN 00 BT 1 4A<cr>        (Batch counter = 1)
AUN 00 RT 0 59<cr>        (Rate meter = 0)
AUN 00 P1 0.75 CE<cr>     (Preset 1 = 0.75)
AUN 00 P2 1.50 C9<cr>     (Preset 2 = 1.50)
AUN 00 PB 43 7C9<cr>     (Batch preset = 43)
```

QAD - Query All Run Data

This command causes the unit to transmit all counter, preset, rate, count scale factor, and rate scale factor values.

Example Command: >00QAD36<cr>

Example Response:

```
AUN 00 CT 1.02 P1 0.75 P2 1.50 BT 1 PB 43 RT
0 SF 1.00000 RM 0.0000.0 C6<cr>
```

QMD - Query Menu Data

This command causes the unit to transmit all values selected with function code 91.

Example Command: >00QMD42<cr>

Example Response (if function 91 = 263):

```
AUN 00 CT 1.02 BT 1 RT 0 F8<cr>
```

QAP - Query All Function Codes

This command causes the unit to transmit the current setting of all its function codes.

Example Command: >00QAP42<cr>

Example Response:

```
AUN 00 F05 1.00000 F11 7 F12 0 F13 6 F14 9 F30
0.10 F31 10.00 F32 0.00 F33 3 F36 1 F39 0 F41
7 F60 0 F62 2 F63 0 F64 1.0000.0 F72 0 F73 0
F74 0 F75 1 F76 0 F77 0 F79 0 F80 0 F81 1 F82
0 F83 0 F84 0 F90 2 F91 263 F92 0 F93 1 F94 0
F95 0 F96 0 5B<cr>
```

Qxx - Query Function Code xx

This command allows a host computer to read the current setting of any function code in the unit.

Example Command: >00Q8019<cr> Query function code 80.

Example Response: AF80 0 1E<cr> (function code 80 = 0).

RDV- Read Device Version

This command causes the unit to respond with the following information:

A3r00uuss<cr> where A = acknowledge
3 = High Speed President family
r00 = software revision number
uu = unit ID number
ss = checksum

Example Command: >00RDV4C<cr>

Example Response: A32000025<cr>

Transmit Input - If the unit is in the enhanced communication mode (function 93 = 1) and a transmit input is activated (functions 11 through 14) the unit will transmit the programmed values (function 91) in an expanded format. If function 91 is programmed to transmit all values, the output might look like this:

```
UNIT NO. 00
MAIN COUNT          1.02
PRESET 1            0.75
PRESET 2            1.50
BATCH COUNT         1
BATCH PRESET        43
RATE                0
SCALE FACTOR        1.00000
Rate MULT.          1.0000.0
```

STANDARD COMMUNICATIONS: RETRIEVING/SENDING DATA

Retrieving Data From Counter

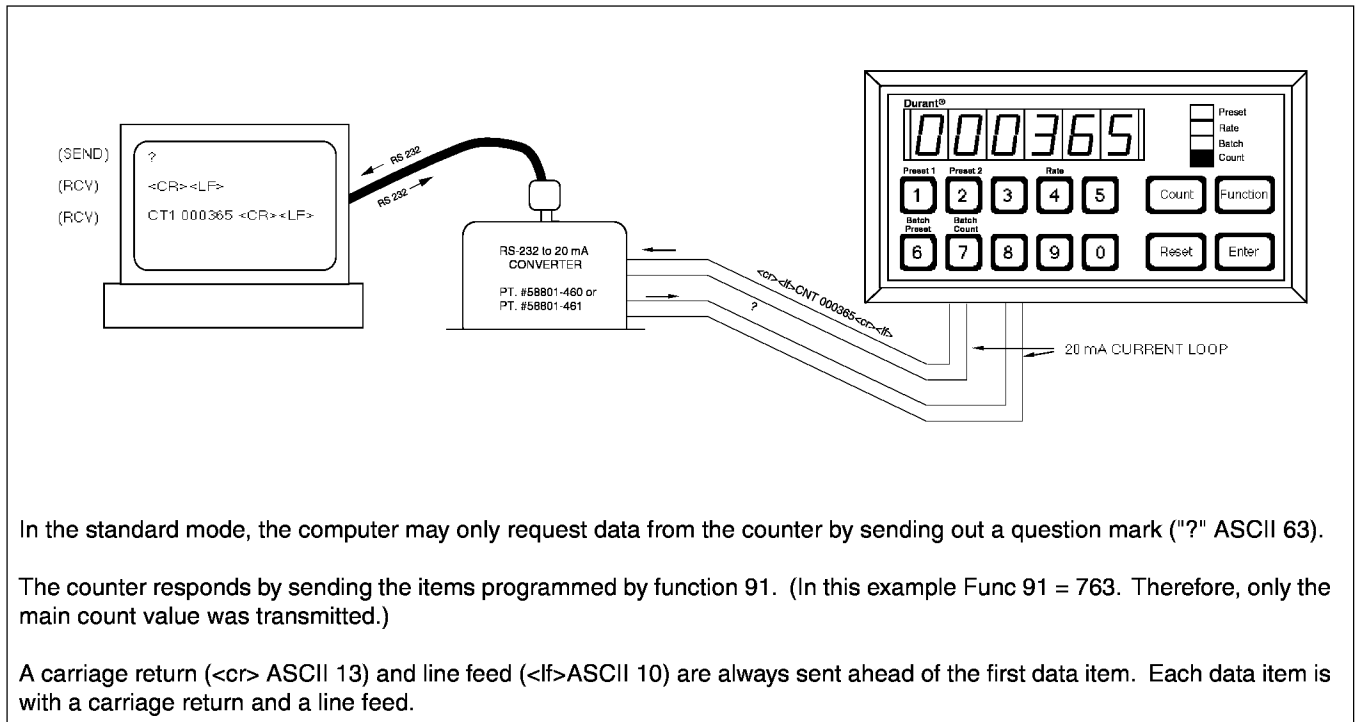

Retrieving Data From Counter

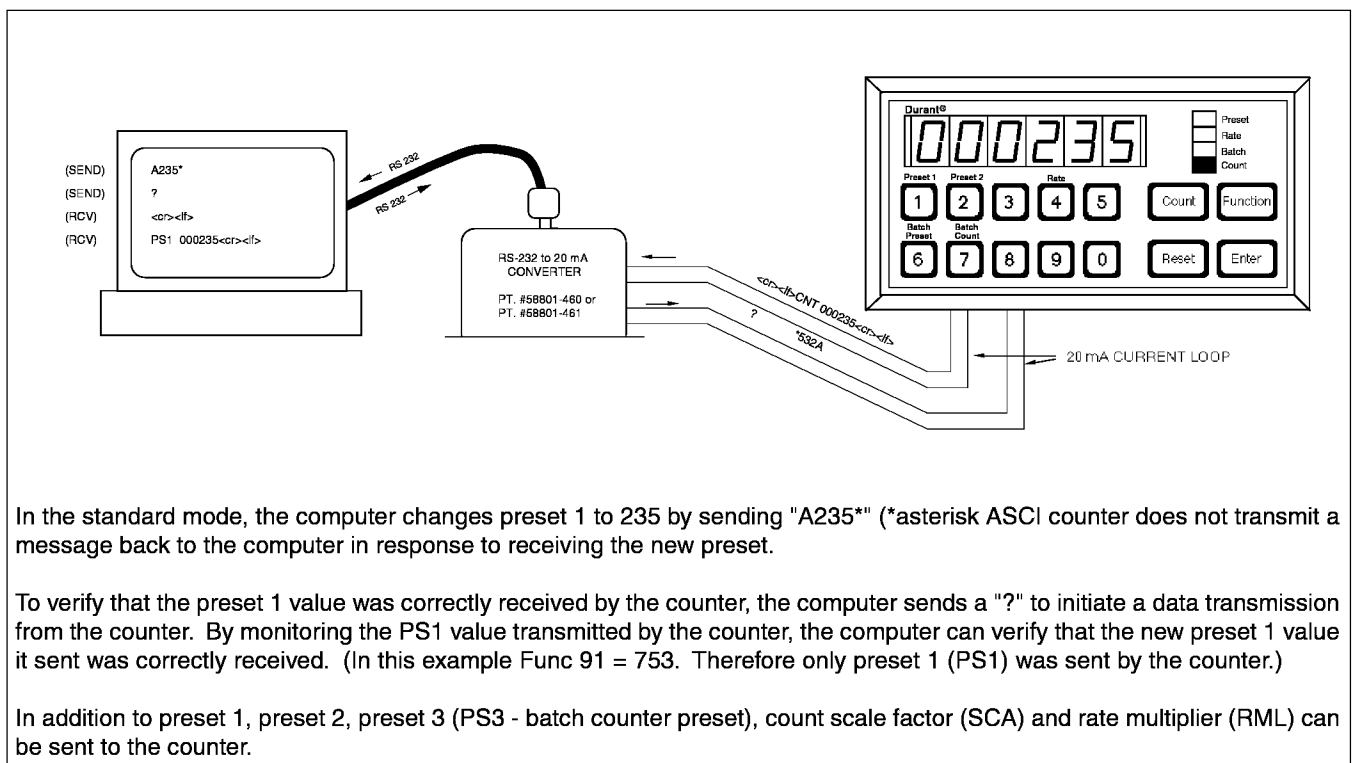

ENHANCED COMMUNICATIONS: RETRIEVING/SENDING DATA

Retrieving Data From Counter

(SEND) `>00QMC41<cr>`
 (RCV) `AUN 00 CT 365 B8<cr>`

RS-232 to 20 mA CONVERTER
 PT. #58801-460 or
 PT. #58801-461

AUN 00 CT 365 B8<cr>
 <cr>14CMQ00<

20 mA CURRENT LOOP

Durant®
 000365
 Preset 1 Preset 2 Rate
 1 2 3 4 5 Count Function
 Batch Preset Batch Count
 6 7 8 9 0 Reset Enter

In the enhanced mode, the computer may request specific data from the counter or request all items programmed by function 91). This example shows the computer specifically requesting the main counter data from unit 0. The computer does this by sending the query main counter command (QMC). (See enhanced command format page 19.)

The counter responds by acknowledging (A), sending its ID number (UN 00), sending the main count value (CT 365), sending a checksum (B8), and terminating the message with a carriage return. If the counter detected an error in transmission, it would send the not acknowledge character - N followed by an error code.

The counter does not precede the transmission with a carriage return or line feed. All transmissions are terminated with a carriage return.

Retrieving Data From Counter

(SEND) `>00LP1235C7<cr>`
 (RCV) `A<cr>`
 (SEND) `>00QP132<cr>`
 (RCV) `AUN 00 P1 235 9E<cr><lf>`

RS-232 to 20 mA CONVERTER
 PT. #58801-460 or
 PT. #58801-461

A<cr> AUN 00 P1 235 9E<cr><lf>
 <cr>231PQ00< <cr>7C5321PL00<

20 mA CURRENT LOOP

Durant®
 000235
 Preset 1 Preset 2 Rate
 1 2 3 4 5 Count Function
 Batch Preset Batch Count
 6 7 8 9 0 Reset Enter

In the enhanced mode, the computer changes preset 1 to 235 by sending the load preset 1 command (LP1). (See enhanced command format page 19.) The counter responds by sending the acknowledge character - A (ASCII 65). If the counter detected an error in transmission, it would send the not acknowledge character - N followed by an error code.

To verify that preset 1 was received by the counter, the computer sends the query preset 1 command (QP1). The counter responds by acknowledging (A), sending its ID number (UN 00), sending the preset 1 value (P1 235), sending a checksum (9E), and terminating the message with a carriage return (ASCII 13).

In the enhanced mode, all function codes, counter values, and preset values can be accessed individually or in groups (see QAP commands).

COMMUNICATION: WIRING / WIRING GUIDELINES

Communication Wiring

Wire 20 mA communication circuits as follows:

Device 1		Device 2
SDO+	-----	SDI-
SDO-	-----	SDI+
SDI+	-----	SDO-
SDI-	-----	SDO+

(SDO = Serial Data Out, SDI = Serial Data In)

Wiring Guidelines

Keep all wiring as short as possible. Do NOT loop excess communication wires.

Do NOT route communication cables with power carrying lines.

Use shielded, twisted pair for communication wiring. Use 20 AWG for runs of 500 feet or less. Runs between 500 and 2000 feet require 18 AWG wire. The maximum distance for any one 20 mA signal is 2000 feet.

Ground the cable shields at the receive (SDI) ends of the communication circuit. The shields should be left unconnected at the transmit (SDO) ends.

Communication Wiring

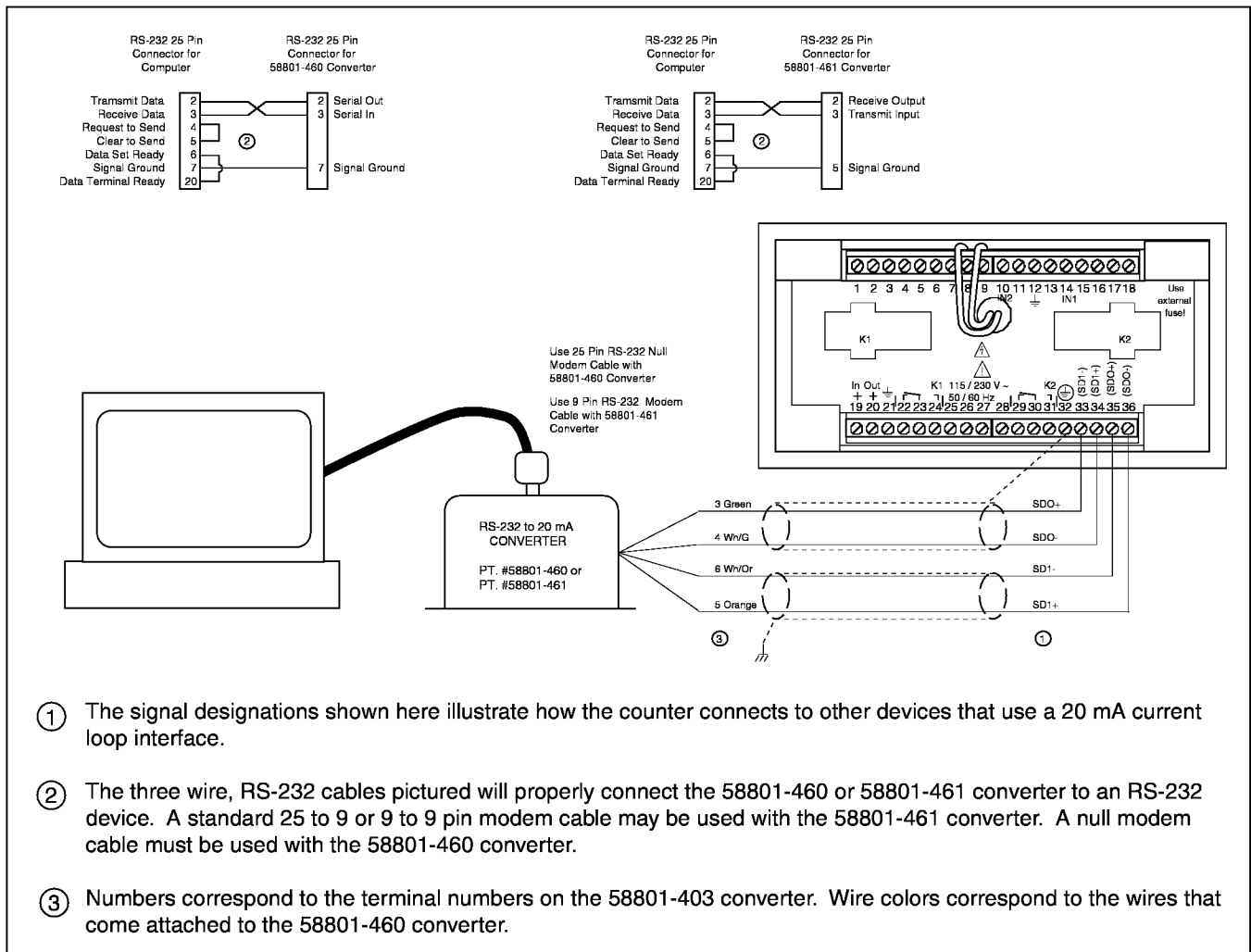

COMMUNICATION: NETWORKING

Communication Network

More than one counter can be connected to an intelligent host device (computer, PLC, etc.) through the use of Durant's Star Network Controller (SNC). The SNC can be thought of as a 16 position selector switch. The switch position is controlled serial commands from the host device. The SNC allows the host device to randomly access any counter in the network at any time.

Up to 16 SNC's can be combined into a single network. Dip switches on the SNC's allow each to be given its own unique address, thus allowing multiple SNC's to function as one large SNC. A distributed SNC system also allows you to simplify wiring since you do not have to connect each counter in the network back to one location.

Star Network Operation

The Star Network Controller operates like a 17 position selector switch with 16 addressable ports and one expansion port. Only one port position can be switched on at any time. Communication with counters occurs through the addressable ports. Data is sent to, and received from, the next SNC via the expansion port.

The Host device (computer, PLC, etc.) controls all network activities. Information sent from the host is received and echoed by every SNC in the system. Address commands sent from the host are received by each SNC in the network, but only the SNC with the correct address range sent will switch on the selected port. All other SNC's will switch to their expansion ports. The host can then communicate with the counter wired to the port that is switched on.

Networking Counters

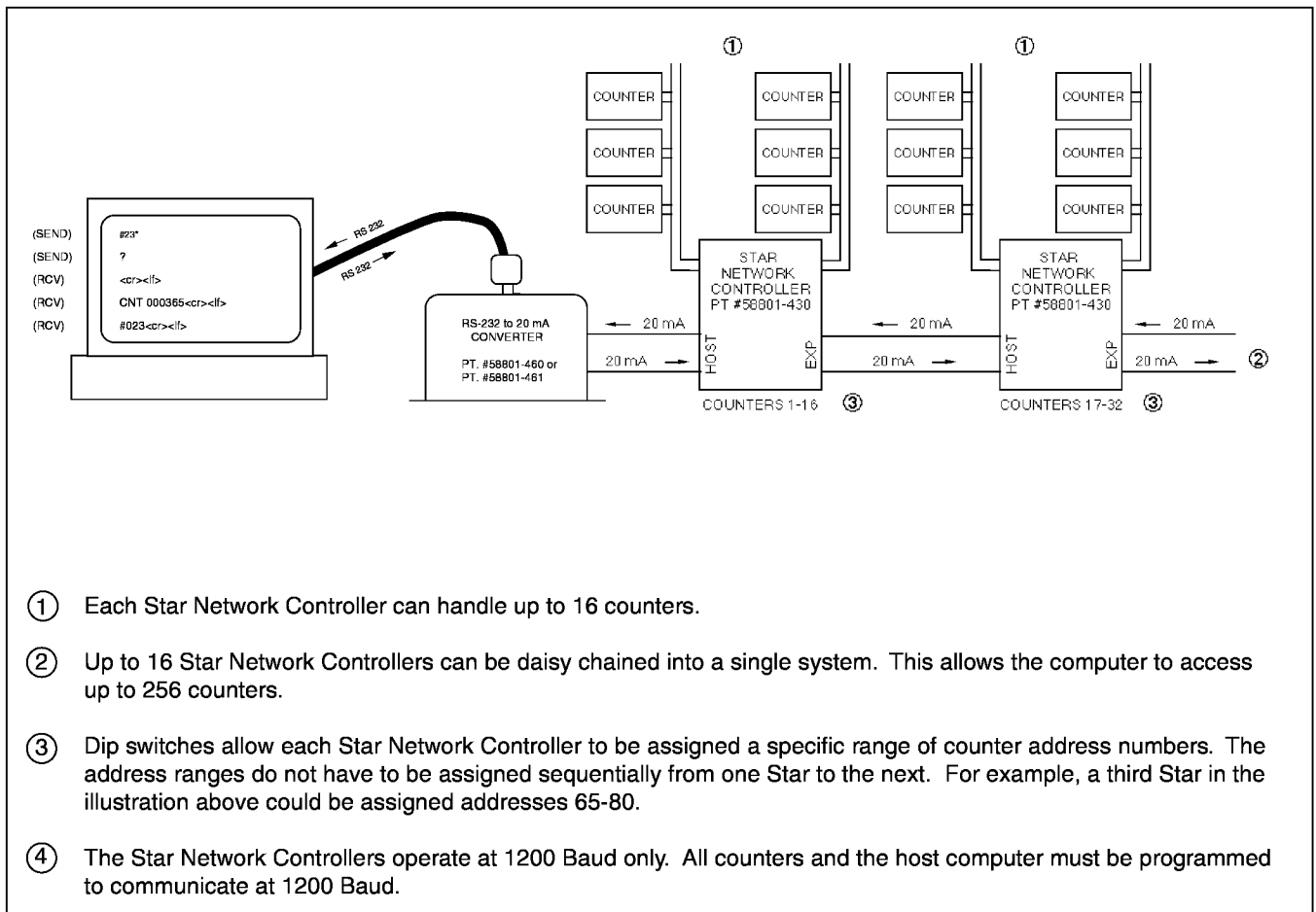

EXPLANATION OF BLOCKS USED IN BLOCK DIAGRAM

Count Mode Logic - Processes all count signals into separate up and down signals for the scaler (these signals are combined into one input for the rate meter). In quadrature modes, this block produces up and down signals based on the phase relationship of the two count input signals. In doubled or quadrupled modes, it produces pulses based on input transitions (high to low or low to high) to achieve increased resolution.

Scaler - Receives the up and down signals from the count mode logic block and adds or subtracts the scale factor value (func 5) to/from the current scaler remainder. The integer result is added to or subtracted from the main counter depending on the direction of the input signal. The scaler retains the fractional portion of the result.

Main Counter - Adds and subtracts the scaled up and down signals from the count value and constantly compares the count value to the preset values. If the count value equals a preset value, the main counter sends a signal to the corresponding output logic block. A signal on the reset input causes the count value to go to zero.

Batch Counter - Each time the main counter reaches preset 2, the batch counter adds one count. If the batch count

value equals the batch preset, the batch counter sends a signal to the batch output logic block. A signal on the reset input causes the batch count value to go to zero.

Output Logic Block - An output logic block acts like a latching relay. When a signal is received at the Latch input the normal output turns on and stays on until a pulse is received at the unlatch input. The reverse output is always in the opposite state of the normal output. (On power up both normal and reverse outputs are off until an unlatch signal occurs.)

Output Timer Block - An output timer block resets its internal timer and begins timing when a pulse is received at its timer start/reset input. When the amount of time specified by the timer's function code has elapsed, the timer sends an output signal on its timed-out output to the associated output logic block. If the timer's function code is set to zero, no timed-out pulse will occur.

Rate Meter - The rate meter block calculates the rate based on the time duration of a pulse or a group of pulses from the count mode logic block. Function 64 (rate meter factor) is used in the calculation so the rate can be displayed in meaningful engineering units.

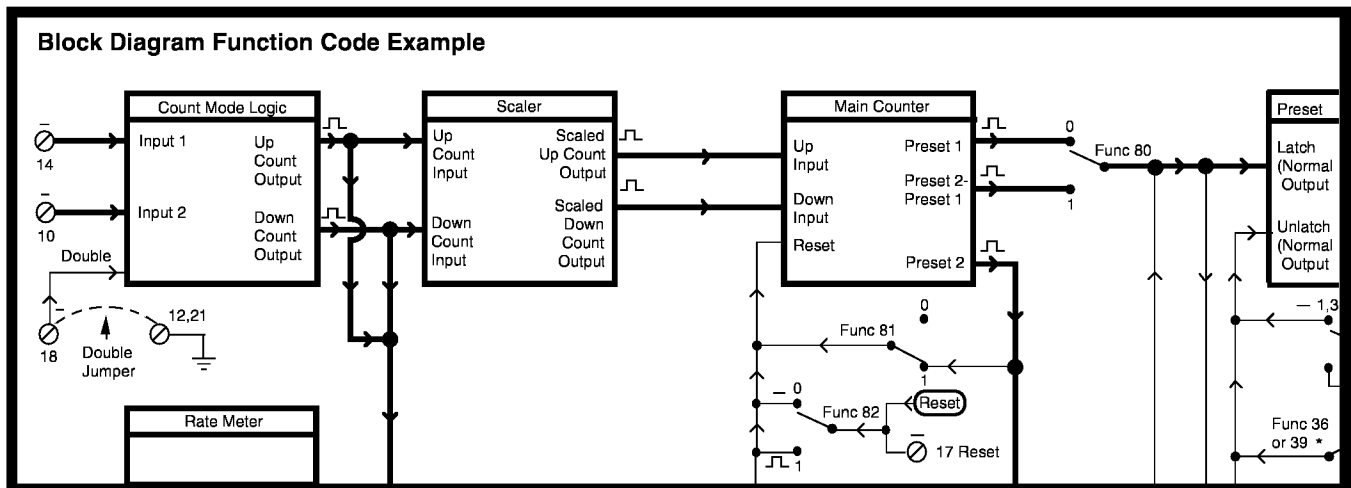

In the above pictured example, Function 81 has been switched from the factory setting position of 0 to the value of 1. This allows the pulse that occurs at the Coincidence Output of Counter 1 to be routed back to the Reset input of Counter 1. In other words, because Function 81 is in the 1 position, Counter 1 will auto-recycle when it counts to its preset value.

The purpose of every Function Code pictured on the block diagram can be seen by tracing the signals from their source, through the Function switches, to their destinations (s).

Remember, signals **CANNOT** travel against the arrows.

FUNCTIONAL BLOCK DIAGRAM

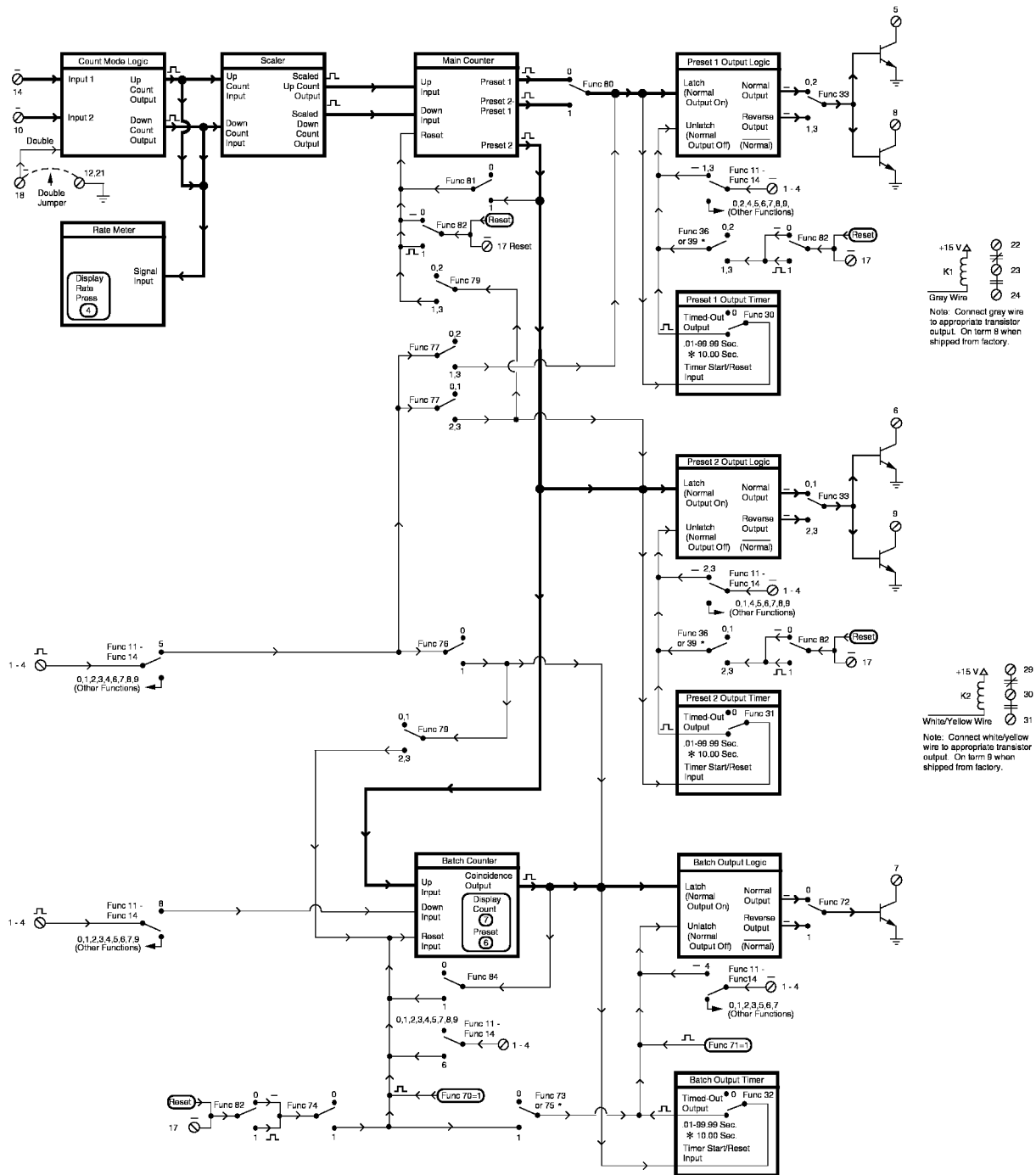

+15 V Δ 22
 K1 23
 24
 Gray Wire
 Note: Connect gray wire to appropriate transistor output. On term 8 when shipped from factory.

+15 V Δ 29
 K2 30
 31
 White/Yellow Wire
 Note: Connect white/yellow wire to appropriate transistor output. On term 9 when shipped from factory.

KEY

- Function Code Information Not Illustrated by Signal Paths
- Indicates Key Stroke(s)
- Back Panel Screw Terminal
- Function Codes Drawn In Factory Set Positions. To Restore All Functions to Factory Settings, Program Func 43 = 1.
- Maintained Signal
- Momentary (One-Shot) Signal
- Signals Flow in Direction of Arrows Only
- Factory Setting of Function Code That Has a Range of Values
- DC Common Terminals 12, 21

NOTE: When more than 1 number is listed for a func switch position, that func also controls similar logic in another place on the diagram. Example: Func 33 - Output 1 and 2 reverse logic.

COUNT MODE LOGIC

FUNC	INP1	INP2	DOUB	Option
60	14	10	18	
*1	Quadrature X1	Add	No	
2	Quadrature X2		No	
3	Quadrature X4		No	

KEYBOARD OPERATION

- To change a preset press:
- [Count] [Preset Key] [New Value] [Enter]
- To program a function code press:
- [Function] [Function Number] [Enter] [New Value] [Enter]

* NOTE Func 36 and 73: Cause an unlatch signal when reset is released.
 Func 39 and 75: Cause an unlatch signal when reset is initiated.

DIAGNOSTICS

Internal Diagnostics

The 58867-400 counter contains several built-in diagnostic tests. The counter performs these tests each time power is applied. The tests can also be initiated manually from the keyboard. If questionable operation ever occurs, run the diagnostic routines by either removing and reapplying power or setting function code 40 equal to 1.

Description of the Diagnostic Routines

- 1 -ROM (Read Only Memory) Test: This routine checks that the ROM, which holds the counter's operating program, is not corrupted.
- 2 -RAM (Random Access Memory) Test: This routine checks the read / write memory used by the counter for normal operation and communication.
- 3 + 4 - Non-Volatile RAM Tests: These routines check the memory used to store the function code values, count values and preset values while power is removed.
- 5 - Non-Volatile RAM Checksum Test: This routine checks that the power up information retrieved from the Non-Volatile RAM matches the information that was stored there when the counter powered down.
- 6 - Watch Dog Timer Test: This routine monitors the operation of the control. If a problem should occur during normal operation, the number 6 will flash on the display and the counter will stop operating. This problem is usually caused by excessive electrical noise and does not necessarily indicate a hardware problem with the counter.

Automatic Diagnostic Operation

The counter automatically performs tests 1, 2, 3 and 5 when power is first applied. If a test fails, the corresponding test number will be flashing continuously.

Manual Diagnostic Operation

The counter will NOT continue its normal operation while manual diagnostics are performed. **It is necessary to stop**

 **the machine or process that the counter controls while manual diagnostics are operating. A serious safety hazard could result if the process is allowed to run during diagnostics.** Manual diagnostics are initiated by programming Function 40=1. The following sequence of events will then occur:

1. The counter displays a six digit number for about two seconds. This number is the unit's software version.
2. All display elements (all 8's) light for 1/2 second.
3. The display counts down from 6 to 1 and turns on amber LEDs while the unit performs the internal tests.
4. The counter returns function 40 to a value of zero and displays the function code 40 value (0). If one of the tests fails, the counter flashes the displayed test number.

When the display shows "0", the manual diagnostics are complete.

What to Do When a Diagnostic Test Failure Occurs

1. Immediately halt the machine or process being controlled by the counter.
2. Record the number being flashed and press the function key to clear the error.
3. Run the manual diagnostics by programming Function 40=1.
4. If the same error occurs again there is a malfunction within the counter - return it to the factory for repair. If all of the diagnostic tests pass, the unit is OK and can be put back in service.

 **Before starting the machine process again, check all function code values to insure that the counter's program has not changed. A serious safety hazard could result if the operating characteristics of the counter have changed.**

TROUBLESHOOTING

Some of the troubleshooting steps that follow require function code values to be changed. Be sure to restore the function code values required by your specific application before putting the unit back into service.

I. Display is Blank:

- A. Check that incoming power is wired correctly. Connect a voltmeter to the power input terminals and verify that the correct voltage is being supplied to the counter.
- B. Remove and restore power to the counter. If this corrects the problem investigate the following causes:
 1. Counter NOT properly grounded - Terminal 32 of counter must be connected to a good electrical ground.
 2. Electrical noise spike from inductive loads - install RC suppressors in parallel with any external solenoid or relay coils that the counter controls.
 3. Electrical noise spikes in power supplied to the counter - run power to counter from another source or install a power line filter.

II. Counter Will Not Count:

- A. Check the count scale factors (Func 5) and verify that they set to the correct value. Set the scale factor to 1.0000 and try counting again before proceeding any further with troubleshooting.
- B. Test Counter using a manual count source .
 1. Program Func 60 = 0, Func 5 = 1.0000. Set the presets = 0.
 2. Remove any wires connected to terminals: 1, 2, 3, 4, 10, 14 and 17.
 3. Make and break a connection between terminals 10 and 12 using a jumper wire. The main counter value should increase each time the connection makes. (Don't worry about extra counts per connection). If the main counter does not count, send the unit to the factory for repair.
 4. Make and break a connection between terminals 14 and 12 using a jumper wire. The main counter value should decrease each time the connection makes. (Don't worry about extra counts per connection.) If the main counter does not count, send the unit to the factory for repair.

- C. If the main counter operated from the manual count source in step B above, reconnect the sensor and perform the following tests:

1. With the sensor output in the high state, measure the voltage between DC common and the count input. The voltage must be greater than 10.5 VDC. If it is lower, the sensor is defective, leaky, or is not compatible with the counter. With current sinking sensors, try adding a pull-up resistor (470 Ω to 4.7 k Ω) from terminal 20 to the count input.
2. With the sensor in the low state, measure the voltage between DC common and the count input. The voltage must be less than 4.5 VDC. If it is higher, the sensor is defective, leaky, or is not compatible with the counter. With current sourcing sensors, try adding a pull-down resistor (220 Ω to 2.2 k Ω) from terminal 12 or 21 to the count input.

III. Single Digit Number Flashing on Display:

A single digit number (1-6) flashing on the display indicates that the counter's internal diagnostics have detected a problem. See the internal diagnostic section of this manual (p. 28) to determine what caused the problem and how to solve it.

IV. Other Problems:

Other problems are usually caused by programming and /or wiring errors. Because of the versatility or this counter, it is impossible to include troubleshooting instructions for every situation that could arise. However, the following general troubleshooting steps should help in resolving specific problems:

- A. Define, in detail, exactly what the problem is and when it occurs.
- B. Using the detailed block diagram and/or the function code list, determine which function codes are related to the problem and check their values.
- C. Determine which I/O circuits are related to the problem and check their operation with a meter at the counter's terminal strips.

If going through the above 3 steps did not lead you to a solution, write down the terminal connections and function code settings you are using. Call Cutler-Hammer Wauertown (800-540-9242) and ask for an application engineer to assist you with troubleshooting.

SPECIFICATIONS

Power Requirements:

AC Operation: AC 115/230 V ~ (+10%, -20%) 47 - 63 Hz.
 DC Operation: DC 11-28 V \equiv
 Power: 18 Watts.

DC Power Output:

DC 15 V \equiv (+1, -2).
 150 mA if powered from AC or less than 24 VDC.
 100 mA if powered from 24 VDC or greater.

 **NOTE: DC power output is only regulated if unit is powered by AC or greater than 18.5 VDC.**

Environment:

Operating Temperature: 32 to 130 degrees F (0 TO 55°C).
 Storage Temperature: -40 to 160 degrees F (-40 to 71°C).
 Operating Humidity: 85% relative, non-condensing.
 NEMA 4 rating when mounted with gasket provided.

Physical:

Case Dimensions: 5.38" (137mm)W x 2.62" (66.67mm)H x 5.91" (150.11mm)D.
 Bezel Dimensions: 5.80" (147.3mm)W x 3.04" (77.2mm)H.
 Panel Cut-out: 5.43" (137.92mm)W x 2.68" (68.07mm)H
 Weight: 2.2 lbs.
 Display Size: 6 digits, .56" high

Main Counter:

Type: 6 digit, bi-directional.
 Presets: 2 or 1 with prewarn.
 Reset Modes: Auto or manual reset to zero.
 Scaler Range: 0.00100 to 9.99999.
 Decimal Point: 5 positions, programmable.
 Accuracy: 100% when counter is operated with the specified count speeds and input voltages.

Count Input Frequency:

The maximum count input frequency depends only on the selected count mode (doubled or quadrature x4). The maximum input frequencies shown are with square wave (50% duty cycle) input.

	Count Input Mode		
	X1	X2	X4
High Speed Mode:	30 kHz	15 kHz	7.5 kHz.
Low Speed Mode:	200 Hz	200 Hz	200 Hz.

(Low speed jumpers installed.)

Note: Only function 60 and the double jumper affect the maximum count input speed. The scale factor does not affect the input speed. If the scale factor is set to 9.99999 (10) the unit will count at a maximum rate of 300 kHz.

Control Inputs:

Impedance: 4.75K ohms to +5 VDC.
 Threshold: High +3.5 to +22 VDC.
 Low +0.0 to +1.0 VDC.

Response Time: Min. High 5.3 mS.
 Min. Low 3.9 mS.

Note: The reset and unlatch signals will both occur in less than 200 microseconds after the input signal is detected. The start of the print will occur within 2 milliseconds after the input is detected if the unit is not counting.

Input Voltages:

Count Inputs: 6.8k Ω to +15 VDC (2.2 mA at 0 VDC).
 Control Inputs: 2.2 k Ω to +5 VDC (2.3mA at 0 VDC).

Batch Counter:

Type: 6 digit, bi-directional (increment with main counter preset 2 signal, decrement with external input).
 Presets: 1
 Accuracy: 100% when counter is operated within the specified count speeds and input voltages.

Output Ratings:

Relay Contacts

Type: FORM C (SPDT).
 U.L./C.S.A. Contact Ratings:
 10 amps, resistive, @ 24 VDC or 230 VAC
 1/3 HP @ 115 VAC or 230 VAC
 150 VDC maximum switched voltage
 Mechanical Life: 5,000,000 operations
 Electrical Life: 100,000 operations at resistive rating

Transistor Outputs

Type: Open collector NPN transistor with Zener diode transient surge protection.
 Load Voltage: 30 VDC maximum
 Load Current: 300 milliamps maximum per transistor; 480 milliamps total for all transistors.

Rev. 50-59: Use 90 milliamps per relay coil when calculating total transistor current.

Rev. 60 - up: Use 5 milliamps per relay coil when calculating total transistor current.

Rate Indicator:

Type: 6 digit, 1/tau (time interval).
 Scaler Range: 0.0001 to 99999.
 Decimal Point: 5 positions, programmable.
 Accuracy: 0.1% of reading.
 Update Time: 0.75 seconds (approximate).
 Zero Time: 10 seconds, fixed.

Communication:

Type: 20mA loop (active transmit, passive receive).
 Speed: 100, 300 & 1200 Baud.
 Parity: odd, even, space.
 Format: 1 start bit, 7 data bits (ASCII), 1 parity bit, 1 stop bit (110 baud uses 2 stop bits).

PARTS / ACCESSORIES

Replacement Parts

38133-202	Relay
28720-216	Front Panel Gasket
48433-200	Mounting Clip (Screw for Clip 29801-187)
48720-260	Front Panel Label (self adhesive)

President Family Accessories

58802-420	Desk Mount Kit (enclosure for flat surface mounting)
38820-400	Spacer Kit (reduces depth of unit to 5.38" when panel mounted)
58801-410	20 mA to Parallel BCD Converter
58801-411	Parallel BCD to 20 mA Converter
58801-430	Star Network Controller
58801-460	20 mA to RS-232 Converter
58804-400	Remote Display / Entry Terminal

General Accessories

48160-400	Input Signal Conditioner
48160-440	Timer Module (selectable time base oscillator)
48160-45x	Analog to Frequency Converter
49990-4xx	Simultaneous Input Processor (anti- coincidence counting from multiple input devices)
38091-400	RC Surge Suppressor
36059-45x	Solid State I/O Modules (AC Input and Output, DC Input and Output)

Transducers

3970x-xxx	Medium Duty Shaft Encoder
4806x-xxx	Heavy Duty Shaft Encoder
ES9513-RS	Rotary Contactor
39400-400	Zero Speed Vane Pickup

DIMENSIONS/WARRANTY

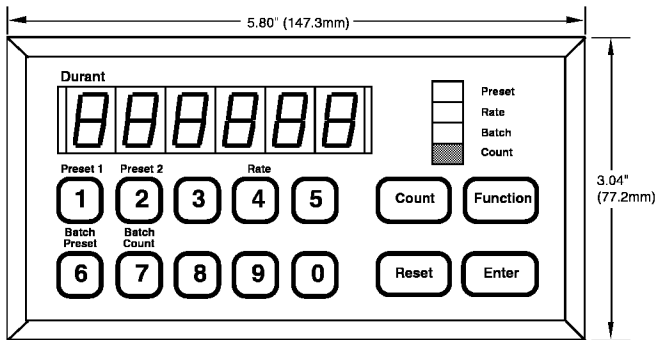

Recommended Panel Cutout: 5.43" (137.92mm) W x 2.68" (68.07mm) H

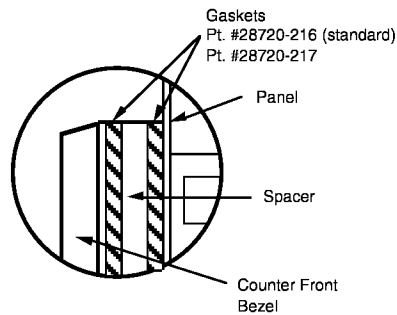

Note: One (1) gasket standard. Second gasket and spacer optional. Use of optional spacer and gasket reduces unit depth from 5.91" (150 mm) to 5.38" (137.3mm).
Spacer Kit Pt. #38820-400

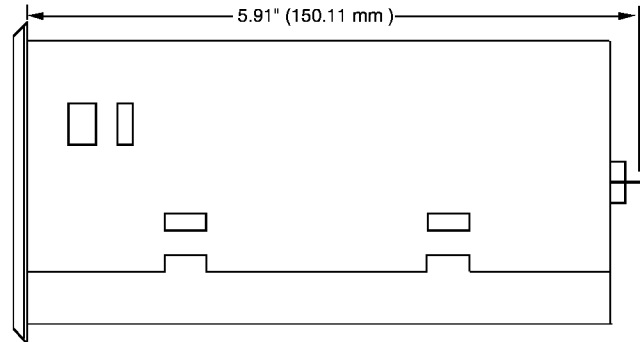
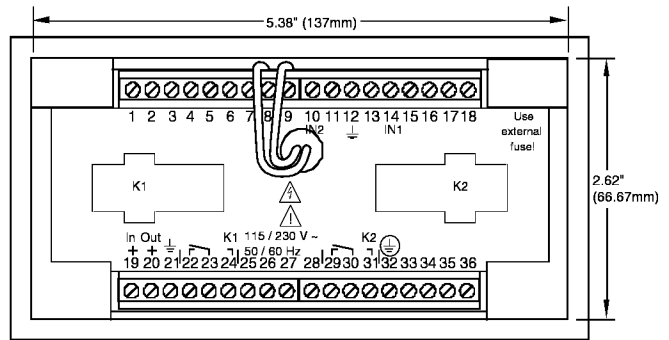

WARRANTY: Eaton warrants all products against defects in material and workmanship for a period of one (1) year from the date of shipment to Buyer. This is a limited warranty limited to its terms. This warranty is void if the product has been altered, misused, taken apart or otherwise abused. ALL OTHER WARRANTIES, EXPRESS OR IMPLIED, ARE EXCLUDED, INCLUDING BUT NOT LIMITED TO THE IMPLIED WARRANTIES OF MERCHANTABILITY AND FITNESS FOR PURPOSE.

BUYERS REMEDIES: Eaton's obligations and liabilities under the foregoing warranty are limited to repair or replacement of the product without charge, provided it is mailed prepaid to Eaton Corp., 901 South Twelfth Street, Watertown, Wisconsin 53094. A charge is made for repairing after the expiration of the warranty. IN NO EVENT SHALL EATON BE LIABLE FOR CLAIMS BASED UPON BREACH OF EXPRESS OR IMPLIED WARRANTY OR NEGLIGENCE OR ANY OTHER DAMAGES WHETHER DIRECT, IMMEDIATE, FORESEEABLE, CONSEQUENTIAL OR SPECIAL OR FOR ANY EXPENSES INCURRED BY REASON OF THE USE OR MISUSE, SALE OR FABRICATION OF PRODUCTS WHICH DO OR DO NOT CONFORM TO THE TERMS AND CONDITIONS OF THIS CONTRACT.

INDEMNIFICATION: Buyer agrees to hold Eaton harmless from, defend, and indemnify Eaton against damages, claims and expenses arising out of subsequent sales of Durant products or products containing components manufactured by Eaton and based upon personal injuries, deaths, property damage, lost profits, and other matters for which Buyer, its employees or sub-contractors are or may be to any extent liable, including without limitation penalties imposed by the Consumer Product Safety Act (P.L.92-573) and liability imposed upon any person pursuant to the Magnuson-Moss Warranty Act (P.L.93.637), as now in effect or as amended hereafter. The warranties and remedies provided for herein are available to Buyer and shall not extend to any other person.

COMPLIANCE WITH OSHA: Eaton offers no warranty and makes no representation that its products comply with the provisions or standards of the Occupational Safety and Health Act of 1970, or any regulations issued thereunder. In no event shall Eaton be liable for any loss, damages, fines, penalty or expense arising under said ACT.

This manual constitutes proprietary information of Eaton Corp., and is furnished for the customers use in operating the described Count Control. Reproduction of this material for purposes other than the support of the described control or related products is prohibited without the prior written consent of Eaton Corp., Watertown, WI.

In the construction of the Control described herein, the full intent of the specifications will be met. Eaton Corp., however reserves the right to make, from time to time and without proper written notice, such departures from the detail specifications as may be required to permit improvements in the design of the product.

The information included herein is believed to be accurate and reliable; however, no responsibility is assumed by Eaton Corp., for its use nor for any infringements of patents or other rights of third parties which may result from its use.

This equipment is capable of generating radio frequency energy. If not installed and used in accordance with the instructions, this unit may interfere with radio communications.

Printed in U.S.A.

Durant
901 South 12th Street
Watertown, WI 53094
920-261-4070 • 800-540-9242 • FAX 920-261-9097