



Powering Business Worldwide

COOPER POWER  
SERIES

## Distribution Transformers

---

Functional Specification Guide

Three-Phase Pad-Mounted Compartmental Type

**PS202002EN**

---

### Functional Specification for Three-Phase Pad-Mounted Distribution Transformers 45 – 10,000 kVA

#### 1.0 Scope

- 1.1. This specification covers the electrical and mechanical characteristics of Eaton's Cooper Power series 45-10,000 kVA Three-Phase Step-Down Pad-Mounted Distribution Transformers. KVA ratings for transformers with secondary voltages not exceeding 700V are 45-3,750 kVA, while kVA ratings for transformers with secondary voltages greater than 700V are 1,000-10,000 kVA. Product is per Catalog Data CA202003EN.

#### 2.0 Applicable Standards

- 2.1. All characteristics, definitions, and terminology, except as specifically covered in this specification, shall be in accordance with the latest revision of the following ANSI<sup>®</sup>, IEEE<sup>®</sup>, NEMA<sup>®</sup>, and Department of Energy standards.

IEEE Std C57.12.00<sup>™</sup>-2010 standard – Standard for Standard General Requirements for Liquid-Immersed Distribution, Power, and Regulating Transformers.

IEEE Std C57.12.28<sup>™</sup>-2014 standard – Pad-Mounted Equipment - Enclosure Integrity.

IEEE Std C57.12.34<sup>™</sup>-2009 standard – Standard Requirements for Pad-Mounted, Compartmental-Type, Self-Cooled, Three-Phase Distribution Transformers (2500 kVA and Smaller) - High Voltage: 34500GrdY/19920 Volts and Below; Low-Voltage: 480 Volt 2500 kVA and Smaller (*issued in March 2005 - combines IEEE Std C57.12.22 and IEEE Std C57.12.26 standards*).

IEEE Std C57.12.90<sup>™</sup>-2010 standard – Standard Test Code for Liquid-Immersed Distribution, Power, and Regulating Transformers and IEEE Guide for Short-Circuit Testing of Distribution and Power Transformers.

IEEE Std C57.12.91<sup>™</sup>-2011 standard – Guide for Loading Mineral-Oil-Immersed Transformers.

NEMA TR 1-1993 (R2000) – Transformers, Regulators and Reactors, Table 0-2 Audible Sound Levels for Liquid-Immersed Power Transformers.

NEMA 260-1996 (2004) – Safety Labels for Pad-Mounted Switchgear and Transformers Sited in Public Areas.

10 CFR Part 431 – Department of Energy – Energy Conservation Program: Energy Conservation Standards for Distribution Transformers; Final Rule.

### 3.0 Ratings

- 3.1. The transformer shall be designed in accordance with this specification and the kVA rating shall be:

45, 75, 112.5, 150, 225, 300, 500, 750, 1000, 1500, 2000, 2500, 3000, 3750, 5000, 7500, 10,000 (range may also be specified).

- 3.2. The primary voltage, configuration, and the basic lightning impulse insulation level (BIL) shall be \_\_\_\_\_, {make a selection from Table 1} Dual voltages are also available.

- 3.3. The secondary voltage, configuration, and the basic insulation level (BIL) of the secondary voltage shall be \_\_\_\_\_, {make a selection from Table 1}

**Table 1**  
**Ratings for Three-Phase Transformers**  
**(Single Ratio)**

Primary Voltage	BIL (kV)		Secondary Voltage	BIL (kV)
2400 Delta	60		208Y/120	All 30 kV
4160 Delta	60		480Y/277	
4800 Delta	60		575Y/332	
7200 Delta	75		600Y/347	
12000 Delta	95		690Y/398	
12470 Delta	95		240 Delta	
13200 Delta	95		480 Delta	
13800 Delta	95		240 Delta with 120 Mid-Tap	
14400 Delta	95		480 Delta with 240 Mid-Tap	
16430 Delta	125			
34500 Delta	150		See left column for voltages over 700 V	
43800 Delta	250			
4160GrdY/2400	60			
8320GrdY/4800	75			
12470GrdY/7200	95			
13200GrdY/7620	95			
13800GrdY/7970	95			
22860GrdY/13200	125			
23900GrdY/13800	125			
24940GrdY/14400	125			
34500GrdY/19920	150			
43800GrdY/25300	250			

- For complete connector rating, see IEEE Std 386™-2006 standard.
- Transformers are suitable for connectors with phase-to-ground or phase-to-ground/phase-to-phase high-voltage ratings as listed.

- Arrester coordination may require higher BIL on multiple connections than indicated to achieve a minimum protection level of 20%.

3.4. The transformer may be furnished with full capacity high-voltage taps. The tap changer shall be clearly labeled to reflect that the transformer must be de-energized before operating the tap changer as required in Section 4.3 of IEEE Std C57.12.34™-2009 standard. The tap changer shall be operable on the higher voltage only for transformers with dual voltage primaries. The unit shall have one of the following tap configurations:

No Taps

Two – 2 ½% taps above and below rated voltage (split taps)

Four – 2 ½% taps below rated voltage (four below)

NEMA taps (14400, 13800, 13200, 12470, 12540)

Non-standard tap configuration

The applicable tap configuration shall be specified on the inquiry.

3.5. The average winding temperature rise above ambient temperature, when tested at the transformer rating, shall not exceed 65 °C **OR** shall not exceed 55 °C **OR** at the base transformer rating, shall not exceed 55 °C, and when tested at 112% of the base rating, shall not exceed 65 °C.

3.6. The percent impedance voltage, as measured on the rated voltage connection, shall be per Table 2. For target impedances, the tolerance on the impedance shall be +/- 7.5% of nominal value for impedance values greater than 2.5%. The tolerance on the impedance shall be +/- 10.0% for impedance values less than or equal to 2.5%.

**Table 2**  
**Percent Impedance Voltage**

KVA Rating (Low voltage < 700 V)	Impedance
75	1.10 - 5.75
112.5-300	1.40 - 5.75
500	1.70 - 5.75
750-3750	5.75 nominal

KVA Rating	Low voltage > 700 V (all nominal values)		
	≤150 kV BIL	200 kV BIL	250 kV BIL
1000 - 5000	5.75	7.00	7.50
7500 - 10000	6.50	7.00	7.50

**4.0 Construction**

4.1. The core and coil shall be vacuum processed to ensure maximum penetration of insulating fluid into the coil insulation system. While under vacuum, the windings will be energized to heat the coils and drive out moisture, and the transformer will be filled with preheated filtered degassed insulating fluid. The core shall be manufactured from burr-

free, grain-oriented silicon steel and shall be precisely stacked to eliminate gaps in the corner joints OR low-loss amorphous metal OR optimal core material based upon specified loading and/or evaluation formula. The coil shall be insulated with B-stage, epoxy coated, diamond pattern, insulating paper, which shall be thermally cured under pressure to ensure proper bonding of conductor and paper. Coils shall be either aluminum or copper (eliminate a metal if one is required over the other).

- 4.2. The dielectric coolant shall be listed less-flammable fluid meeting the requirements of National Electrical Code Section 450-23 and the requirements of the National Electrical Safety Code (IEEE Std C2™-2002 standard), Section 15. The dielectric coolant shall be non-toxic\*, non-bioaccumulating and be readily and completely biodegradable per EPA OPPTS 835.3100. The base fluid shall be 100% derived from edible seed oils and food grade performance enhancing additives. The fluid shall not require genetically altered seeds for its base oil. The fluid shall result in zero mortality when tested on trout fry \*. The fluid shall be certified to comply with the US EPA Environmental Technology Verification (ETV) requirements, and tested for compatibility with transformer components. The fluid shall be Factory Mutual Approved®, UL® Classified Dielectric Medium (UL-EOUV) and UL® Classified Transformer Fluid (UL-EOVK), Envirotemp™ FR3™ fluid.
- \*(Per OECD G.L. 203)

#### 4.3. Tank and Cabinet Enclosure

- 4.3.1. The high-voltage and low-voltage compartments, separated by a metal barrier, shall be located side-by-side on one side of the transformer tank. When viewed from the front, the low-voltage compartment shall be on the right. Each compartment shall have a door that is constructed so as to provide access to the high-voltage compartment only after the door to the low-voltage compartment has been opened. There shall be one or more additional fastening devices that must be removed before the high-voltage door can be opened. Where the low-voltage compartment door is of a flat panel design, the compartment door shall have three-point latching with a handle provided for a locking device. Hinge pins and associated barrels shall be constructed of corrosion-resistant material, passivated ANSI® Type 304 or the equivalent.
- 4.3.2. A recessed, captive, penta-head or hex-head bolt that meets the dimensions per IEEE Std C57.12.28™-2014 standard shall secure all access doors.
- 4.3.3. The compartment depth shall be in accordance with IEEE Std C57.12.34™-2009 standard, unless additional depth is specified.
- 4.3.4. The tank base must be designed to allow skidding or rolling in any direction. Lifting provisions shall consist of four lifting lugs welded to the tank.
- 4.3.5. The tank shall be constructed to withstand 7 psi without permanent deformation, and 15 psi without rupture. The tank shall include a 15 psig pressure relief valve with a flow rate of minimum 35 SCFM.

- 4.3.6. The exterior of the unit shall be painted Munsell 7GY3.29/1.5 green (STD), ANSI® 70 gray, or ANSI® 61 gray in color. If a special paint color is specified, a federal spec number or paint chip must be provided at the time of order. The cabinet interior and front plate shall be painted gray for ease of viewing the inside compartment.
- 4.3.7. The tank shall be complete with an anodized aluminum laser engraved nameplate. This nameplate shall meet Nameplate B per IEEE Std C57.12.00™-2010 standard.

#### 4.4. High Voltage Bushings and Terminals

- 4.4.1. High voltage bushings will be installed in the high voltage termination compartment located on the front left of the transformer and requiring access via the low voltage termination compartment on the front right.

##### 4.4.2. Bushing Style

- [ ] **15/25 KV DEADFRONT, CURRENTS BELOW 200 AMPS:** The high voltage bushings shall be 15/25 kV 200A bushing wells with bushing well inserts installed. The bushings shall be externally removable and be supplied with a removable stud (Re: Catalog Data CA800016EN, 500-12, and 500-26).
- [ ] **35 KV DEADFRONT, CURRENTS BELOW 200 AMPS:** The high voltage bushing shall be a one-piece, 150 kV, 200-amp large interface load-break bushing (Re: Catalog Data CA800021EN).
- [ ] **15/25/35 KV DEADFRONT, CURRENTS ABOVE 200 AMPS:** The high voltage bushing shall be a 600A dead-break primary one-piece bushing externally removable, 3Ø rated, integral design. An optional 900 A bushing is available upon request (Re: Catalog Data CA800025EN and CA800020EN).
- [ ] **36 KV TO 46 kV (250 KV BIL) DEADFRONT APPLICATIONS:** The high voltage bushing shall be a CONNEX® Plug-in Cable Termination System, size 3S. The male and female portions of the bushing shall be supplied with the transformer. Available in radial feed only.
- [ ] **15/25/35 KV LIVEFRONT, 200 KV BIL MAX:** The high voltage bushing shall be a porcelain bushing with a two, four, or six-hole spade or an eyebolt connector.

##### 4.4.3. Bushing Configuration

- [ ] **15/25 KV RADIAL FEED DEADFRONT:** The transformer shall be provided with three (3) high voltage bushings in accordance with Figure 1 dimensions (Figure 4a dimensions may be specified when a larger termination compartment for greater working space is desired) from IEEE Std C57.12.34™-2009 standard for radial feed configurations. The bushing heights shall be in accordance with Figure 3 dimensions (Figure 6 dimensions may be specified for greater bushing height) of IEEE Std C57.12.34™-2009 standard.

- [ ] **15/25 KV LOOP FEED DEADFRONT:** The transformer shall be provided with six (6) high voltage bushings in accordance Figure 2 dimensions (Figure 5a dimensions may be specified when a larger termination compartment for greater working space is desired) of IEEE Std C57.12.34™-2009 standard for loop feed configurations. The bushing heights shall be in accordance with Figure 3 minimum dimensions (Figure 6 dimensions may be specified for greater bushing height) of IEEE Std C57.12.34™-2009 standard.
- [ ] **35 KV RADIAL FEED DEADFRONT:** The transformer shall be provided with three (3) high voltage bushings in accordance with Figure 4b dimensions of IEEE Std C57.12.34™-2009 standard for radial feed configurations. The bushing heights shall be in accordance with Figure 6 dimensions of IEEE Std C57.12.34™-2009 standard.
- [ ] **35 KV LOOP FEED DEADFRONT:** The transformer shall be provided with six (6) high voltage bushings in accordance with Figure 5c dimensions of IEEE Std C57.12.34™-2009 standard for loop feed configurations. The bushing heights shall be in accordance with Figure 6 dimensions of IEEE Std C57.12.34™-2009 standard.
- [ ] **46 KV / 250 KV BIL DEADFRONT:** The transformer shall be provided with three (3) bushings mounted 45° down from the horizontal, 60" from the ground, and 12" apart from each other.
- [ ] **15/25/35 KV LIVEFRONT, 150 KV BIL MAX:** The transformer shall be provided with three (3) bushings in accordance with Figure 9 of IEEE Std C57.12.34™-2009 standard for radial feed configurations. The bushing heights shall be in accordance with Figure 10 of IEEE Std C57.12.34™-2009 standard.
- [ ] **200 KV BIL LIVEFRONT:** The transformer shall be provided with three (3) bushings with phase-to-phase and phase-to-ground clearances adequate for 200 kV BIL.

#### 4.5. Low Voltage Bushings and Terminals

##### 4.5.1. Bushing Style

- 4.5.1.1. Voltages less than 700 Volts: The transformer shall be provided with tin-plated spade-type bushings for vertical takeoff. The spacing of the connection holes shall be 1.75" on center, per IEEE Std C57.12.34™-2009 standard Figure 13a. The quantity of connection holes shall be 4, 6, 8, 12, 16, or 20 holes.
- 4.5.1.2. Transformers 300 kVA and below, and 500 kVA with 480Y/277 secondary will have two-piece low voltage bushings with studs and screw on spades. Transformers 500 kVA with 208Y/120 secondary and all transformers above 500 kVA will have one-piece bushings.

**Table 3**  
**Standard / Maximum Bushing Hole Quantities**

<u>KVA</u>	<u>208Y/120</u>	<u>480Y/277 and higher</u>
45-300	4 standard, 16 maximum	4 standard, 16 maximum
500	6 standard, 12 maximum	4 standard, 16 maximum
750-1500	12 standard, 20 maximum	6 standard, 12 maximum
2000-3750	N/A	12 standard, 20 maximum

(Re: Catalog Data CA800017EN, CA800023EN, and CA800018EN)

- 4.5.1.3. Bushing supports shall be provided for transformers requiring 10 or more connection holes. Bushing supports shall be affixed to the cabinet sidewalls; tank-mounted supports mountings are not acceptable.

#### 4.5.2. Bushing Configuration

The transformer shall be provided with bushings in a staggered arrangement in accordance with Figure 11a dimensions (Figure 12a dimensions may be specified when a larger termination compartment for greater working space is desired) of IEEE Std C57.12.34™-2009 standard.

- 4.5.3. Voltages greater than 700 Volts: Refer to section 3.1 for the bushing type. Secondary arrangements shall be live-front or dead-front. Dead-front application with a required neutral shall have a porcelain X0 bushing. Dead-front application may be loop feed when specified. Provide additional front barrier for high voltage live front secondary, creating an additional barrier after the low voltage door has been opened.

#### 4.6. Switching

- [ ] **Primary Switching:** The primary switching scheme provided with the transformer shall be one (*only available option for radial feed*), two, or three on-off under-oil load-break switch(s), or one four-position V or T-blade load-break sectionalizing switch. Refer to Appendix 1 for the schematics of these switching options (Re: Catalog Data CA800005EN and CA800019EN).

- [ ] **Make-before-break option for four-position, sectionalizing switch:** This switch option provides improved system reliability by eliminating momentary interruptions during switching operations.

- [ ] **External Visible Loadbreak On/Off switch:** The external visible loadbreak switch allows customers to visibly confirm that the transformer is de-energized without having to expose themselves to dangerous arc flash in the transformer compartment.

[ ] **External Visible Loadbreak On/Off/Ground switch**

The external visible loadbreak switch allows customers to visibly confirm that the transformer is de-energized without having to expose themselves to dangerous arc flash in the transformer compartment. This feature also allows the end user to ground the transformer using the load break switch.

**Note:** The external load-break switch can also be supplied with external gauges mounted outside of the transformer cabinet. Refer to Section 9 for the gauges included with this option.

#### 4.7. Overcurrent Protection

[ ] **BAY-O-NET WITH BACK-UP CURRENT LIMITING FUSES:** (available up to 130 amps of full-load transformer current, up to 34.5 kV grounded wye, or 23 kV delta). The high-voltage overcurrent protection scheme provided with the transformer shall be an externally removable loadbreak expulsion Bay-O-Net fuse assembly with a flapper valve to minimize oil spillage. The bayonet fuses shall be in series with ELSP under-oil partial-range current-limiting back-up fuses with an interrupting rating of 50,000 A. (Re: Catalog Data CA132015EN, CA132009EN, CA132010EN, CA132012EN, CA132011EN, CA132007EN, and CA132013EN) *For voltages 23000Y or Delta and above (which must also take into account any higher tap settings), bayonet fuses are not available.*

[ ] **Cartridge fusing, >23kV:** Under-oil cartridge fusing shall be utilized (available up to 208 amps of full-load transformer current, up to 34.5kV delta). The high-voltage overcurrent protection scheme provided with the transformer shall be under-oil cartridge fusing. Cartridge fuses shall be in series with ELSP under-oil partial-range current-limiting back-up fuses with an interrupting rating of 50,000 A.

[ ] **Optional Accessory:** An interlock shall be required between the load-break switch scheme specified and the bayonet fuses, such that the fuses may not be removed unless the transformer has been de-energized via the load-break switch scheme.

[ ] **MAGNEX INTERRUPTER:** (available up to 42 amps of full-load transformer current, up to 35 KV grounded wye, or 17.1 KV delta), The high-voltage overcurrent protection scheme provided with the transformer shall be a three-phase trip MagneX interrupter. This externally resettable device may also be used as an on-off switch. The three-phase MagneX interrupter shall be in series with ELSP under-oil partial-range current-limiting back-up fuses with an interrupting rating of 50,000 A (Re: Catalog Data CA132017EN and CA132013EN).

[ ] **INTEGRAL VACCUUM, FAULT INTERRUPTER (VFI):** (available from 13 amps up to 900 amps of full-load transformer current, up to 34.5 kV, grounded wye or delta, maximum 150 KV BIL) The high-voltage or low-voltage overcurrent protection scheme provided with the transformer shall be an integral Vacuum



Fault Interrupter (VFI). The VFI shall have a maximum interrupting rating of 12,000A RMS symmetrical (optional 16,000 A RMS symmetrical available at 15 KV) with resettable fault protection up through 35 kV. The VFI shall also include a Tri-Phase electronic breaker control with over 100 minimum trip settings and five (5) selectable time current curves. The minimum trip setting shall be XX amps, and curve profile shall be the EF, KF, TF, F, or H (Re: Bulletin B210-02039 and Service Information S285-75-1 for the electronic control).

- [ ] **Optional ELSP Accessory:** VFI shall be in series with ELSP under-oil partial-range current-limiting back-up fuses with an interrupting rating of 50,000 A.
- [ ] **Optional VFI Accessories:** SCADA board; Ground fault detection; Motor operator assembly; Visible break window.

#### 4.8. Overvoltage Protection

4.8.1. The overvoltage protection scheme provided with the transformer shall protect the high-voltage or low voltage winding.

- [ ] **DEAD-FRONT BUSHINGS:** (maximum 150 kV BIL, for voltages up to 18 kV delta and 35 kV grounded wye). Externally mounted, Distribution Class M.O.V.E. Dead-front elbow arresters shall be supplied. (Re: Catalog Data 235-65.) M.O.V.E. arresters are for installation on 200 A rated dead-front bushing interfaces only. *If transformer bushings are rated 600 A or 900 A, BT-TAP elbow connectors, T-OP II elbow connectors, or 600 A bushing adapters, each with a load-reducing tap plug for arrester connection, are required* (Re: Catalog Data CA235018EN and CA235012EN).
- [ ] **LIVEFRONT BUSHINGS:** (up to 200 KV BIL). Distribution- and Intermediate-Class arresters shall be supplied beneath the high-voltage bushings (Re: Catalog Data CA235018EN and CA235012EN).
- [ ] **UNDER OIL:** (for voltages up to 27 kV delta and 35 KV grounded wye). Internally mounted, Distribution Class MOV under-oil surge arresters shall be supplied (Re Catalog Data CA235023EN).
  - [ ] **Optional Accessory:** Three (3) disconnect switches shall be included to disconnect the under-oil arresters from ground for transformer testing (Re: Catalog Data 800-51).

#### 5.0 Optional features to reduce exposure to arc flash

5.1. Additional transformer rating nameplate – In addition to the standard nameplate located on the transformer tank, a second nameplate shall be included. The nameplate shall be mounted external to the termination compartments with an industrial grade double-sided adhesive. Its location shall be identified on the data sheet.

- 5.2. External drain valve with sampler – A 1.0” drain valve with sampling device shall be located outside of the cable compartment on the *[low voltage]* *[high voltage]* side of the tank. The valve shall be protected by a hinged cover with padlock provisions.
- 5.3. External instrumentation package – All included gauges and instrumentation devices shall be located outside of the cable compartments such that access to them does not require exposure to any live circuits. They shall be located inside a separate NEMA<sup>®</sup> 4 rated enclosure on the *[low voltage]* *[high voltage]* side of the tank. Devices shall include the following: liquid level gauge, dial-type thermometer, pressure/vacuum gauge, pressure relief valve, ½” fluid sampling valve, *[temperature transducer]*, *[pressure transducer]*, *[winding temperature indicator]*, *[rapid rise relay]*, *[upper fill plug/valve]*.
- 5.3.1. Alarm contacts *[shall]* *[shall not]* be included on the liquid level gauge, dial-type thermometer, and pressure/vacuum gauges. Any of the accessories above with contacts shall be wired *[to terminal blocks located within the enclosure]* *[via liquid-tight flexible conduit to a terminal block in a [NEMA<sup>®</sup> 4] [NEMA<sup>®</sup> 4X] control box located below the instrument box]*.
- 5.4. External load break switch – The high voltage switch handle shall be located on the exterior tank wall on the high voltage side of the transformer. The switch shall be operable without exposure to any live circuits. The handle shall be protected by a hinged cover with padlock provisions.
- 5.5. External visible load break (EVLB) switch – The high voltage switch shall be located on the exterior tank wall on the high voltage side of the transformer and shall include a viewing window that provides visible confirmation of the switch blade position. The switch shall be of a *[2-position, on/off]* *[3-position, on/off/ground]* configuration and shall be operable without exposure to any live circuits. Hinged covers with padlock provisions shall be provided over the window and over the switch handle. Properly sized current-limiting fuses shall be included in the transformer for additional safety.

Note: The EVLB option is limited to the following ratings:

Line voltage (kV)	Maximum kVA
≥ 12.0 ≤ 34.5	3000
≥ 7.2 < 12.0	2000
≥ 4.16 < 7.2	1000

- 5.5.1. For additional safety and ease of maintenance, the following instrumentation devices shall be located on the front of the external load break switch compartment: liquid level gauge, dial-type thermometer, pressure/vacuum gauge, pressure relief valve and ½” fluid sampling valve. These devices shall be protected by a hinged cover with padlock provisions.

Note: If alarm contacts are required a second set of gauges shall be provided in the low voltage cable compartment with the contacts wired to a terminal block on the metal divider between the compartments.

- 5.6. Infrared (IR) inspection windows – To monitor connections in the high voltage and low voltage compartments without opening the compartment doors, IR window shall be provided. The window(s) shall be IRISS model VPFR-75 or approved equal. The quantity and location of the window(s) shall be indicated on the data sheets.

## 6.0 Labeling

- 6.1. A temporary bar code label shall be attached to the exterior of the transformer in accordance with IEEE Std C57.12.34™-2009 standard.

## 7.0 Finish Performance Requirements

- 7.1. The tank coating shall meet all requirements in IEEE Std C57.12.28™-2014 standard including:

- Salt Spray
- Crosshatch adhesion
- Humidity
- Impact
- Oil resistance
- Ultraviolet accelerated weathering
- Abrasion resistance – taber abraser

- 7.2. The enclosure integrity of the tank and cabinet shall meet the requirements for tamper resistance set forth in IEEE Std C57.12.28™-2014 standard including but not limited to the pry test, pull test, and wire probe test.

## 8.0 Production Testing

- 8.1. All units shall be tested for the following:

- No-Load (85 °C or 20 °C) losses at rated current
- Total (85 °C) losses at rated current
- Percent Impedance (85 °C) at rated current
- Excitation current (100% voltage) test
- Winding resistance measurement tests
- Ratio tests using all tap settings
- Polarity and phase relation tests
- Induced potential tests
- Full wave and reduced wave impulse test

- 8.2. Transformers shall conform to efficiency levels for liquid immersed distribution transformers, as specified in the Department of Energy ruling “10 CFR Part 431 Energy

Conservation Program: Energy Conservation Standards for Distribution Transformers; Final Rule; April 18, 2013.” Manufacturer shall comply with the intent of all regulations set forth in noted ruling.

- 8.3. In addition, the manufacturer shall provide certification upon request for all design and other tests listed in IEEE Std C57.12.00™-2010 standard, including verification that the design has passed short circuit criteria per IEEE Std C57.12.00™-2010 standard and IEEE Std C57.12.90™-2010 standard.
- 8.4. In the event of proposal bid evaluated with guaranteed losses due to a loss evaluation (see section 10.0), manufacturer shall conform to guaranteed average losses as specified in IEEE Std C57.12.00™-2010 standard. The no-load losses of a transformer shall not exceed the specified no-load losses by more than 10%, and the total losses of a transformer shall not exceed the specified total losses by more than 6%.

## 9.0 Approved Manufacturers

- 9.1. Eaton—Waukesha WI

## 10.0 Accessories

- 10.1. The following accessories and options shall be provided:

- Bolted main tank cover (1000 kVA & below)
- Welded main tank cover with bolted handhole (1500 kVA & above)
- 1.0” upper fill plug
- 1.0” drain plug in LV compartment (500 kVA & below)
- 1.0” drain valve w/ sampling device in LV compartment (750 kVA & above)
- Automatic pressure relief valve
- Metal drip shield (when bayonets specified)
- 20” deep cabinet (2500 kVA & below)
- 24” deep cabinet (3000 kVA & above)
- Ground provisions per IEEE Std C57.12.34™-2009 standard section 9.11.
- Meet NEMA® TR-1 sound levels
- Liquid level gauge
- Dial-type thermometer gauge
- Pressure vacuum gauge
- 1.0” drain valve w/ sampling device in (LV or HV) compartment (500 kVA & below)
- Upper fill valve
- Pressure vacuum bleeder
- 24” deep cabinet
- 30” deep cabinet
- 36” deep cabinet
- 40” deep cabinet
- Spare bayonet fuse links
- Fault indicator provisions
- Ground connectors
- Mr. Ouch warning & danger signs

- Danger high voltage warning signs
- Miscellaneous stenciling
- Non-PCB decal
- Touch-up paint
- Interphase barriers (for live front primary units only)
- Seismic zone 3 and 4 tank anchoring
- Complete 304L stainless steel tank and cabinet
- 304L stainless steel tank base and cabinet sides & sill (partial)
- Liquid level gauge with auxiliary contacts
- Dial-type thermometer gauge with auxiliary contacts
- Pressure vacuum gauge with auxiliary contacts
- Current or potential transformers
- Rapid rise relay with seal-in panel
- Winding temperature indicator
- Watt-hour meter package – includes GE kV2c Encompass™ Electronic Meter.  
Factory supplied wiring shall be internal to the cabinet, not in conduit.  
Communication connection shall be the OPTOCOM port.
- Harmonic resistant K-factor design, K=4, 9, 13, or 20
- Forced air ONAF (mineral oil) or KNAF (Envirotemp™ FR3™ fluid) rating. Forced air rating requires documentation from Eaton's customer that they are aware this transformer is no longer tamper resistant and is no longer in compliance with ANSI® standards.
- Future forced air rating
- Forced Air Fan Control Package*
- FM Global® (FM) Approved transformer (to comply with NEC® 450-23 listing restrictions for installations on, near, or inside of buildings)
- Combination UL® Listed & Classified transformer (to comply with NEC® 450-23 listing restrictions for installations on, near, or inside of buildings) per UL XPLH
- UL® Listed transformer (certifying compliance with ANSI® standards only) per UL® XPLH
- External visible break with gauges: Gauges include liquid level, dial-type thermometer gauge, pressure/vacuum, pressure relief valve, and a 1.0" oil sampler valve, and fill plug.

### 11.0 Optional Transformer Evaluation

- No unit evaluation, but include quote losses as reference only on bid.
- Unit loss evaluation, guaranteed average losses. Criteria to properly evaluate quoted losses:
  - Core loss evaluation (A-factor) \_\_\_\_\_ \$/watt
  - Winding loss evaluation (B-factor) \_\_\_\_\_ \$/watt
 (Eaton may be contacted for sample loss evaluation method)

### 12.0 Shipping

- 12.1. Transformers, 1000 kVA and below, shall be palletized. Transformers, 1500 kVA and larger, shall be loaded and unloaded with overhead cranes, so a pallet is not to be provided for these transformers.

### 13.0 Data With Proposal

- 13.1. The following data shall be submitted with the proposal:

- Core losses (when requested per Sections 7.4 and 10.0).
- Winding losses (when requested per Sections 7.4 and 10.0).
- Percent Impedance
- Typical bid drawing
- Approval drawing – drawings shall show final dimensions and features. When requested, approval drawings shall be provided per quoted leadtime.
- Record Drawing – drawings shall show final dimensions and features. When requested, record drawings shall be provided.

### 14.0 Service

- 14.1. The manufacturer of the transformer shall have regional service centers located within two (2) hours flight time of all contiguous 48 states. Service personnel shall be factory trained in commissioning and routine service of quoted transformers.

APPENDIX 1: Switching Options and Schematics

**1 On/Off Switch**

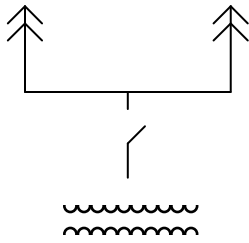

**2 On/Off Switches**

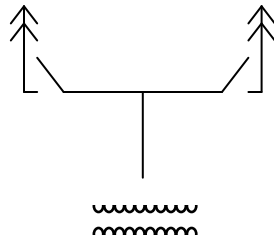

**3 On/Off Switches**

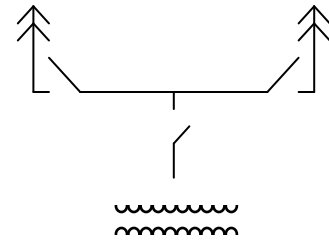

(Re: Catalog Data CA800019EN)

**4-position sectionalizing switches:  
V-blade switch**

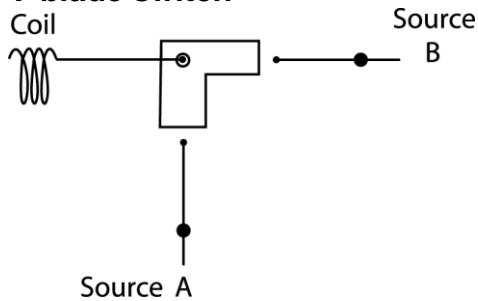

Description of positions:

Feed from A & B

Feed from A only

Feed from B only

Open — the loop is **open** and the transformer is de-energized

**T-blade switch**

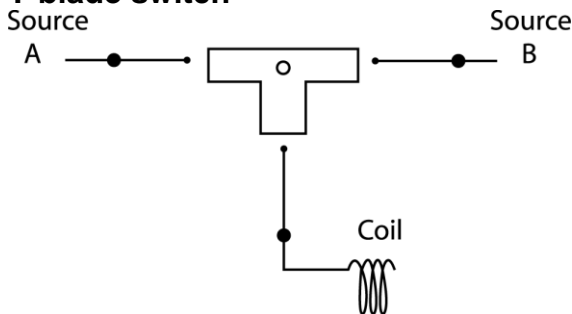

Description of positions:

Feed from A & B

Feed from A only

Feed from B only

Open — the loop is **closed** and the transformer is de-energized

(Re: Catalog Data CA800005EN)