

Quick Connect Assembly (QCA) Retrofit Kit, Siemens/Howard Installation Instructions

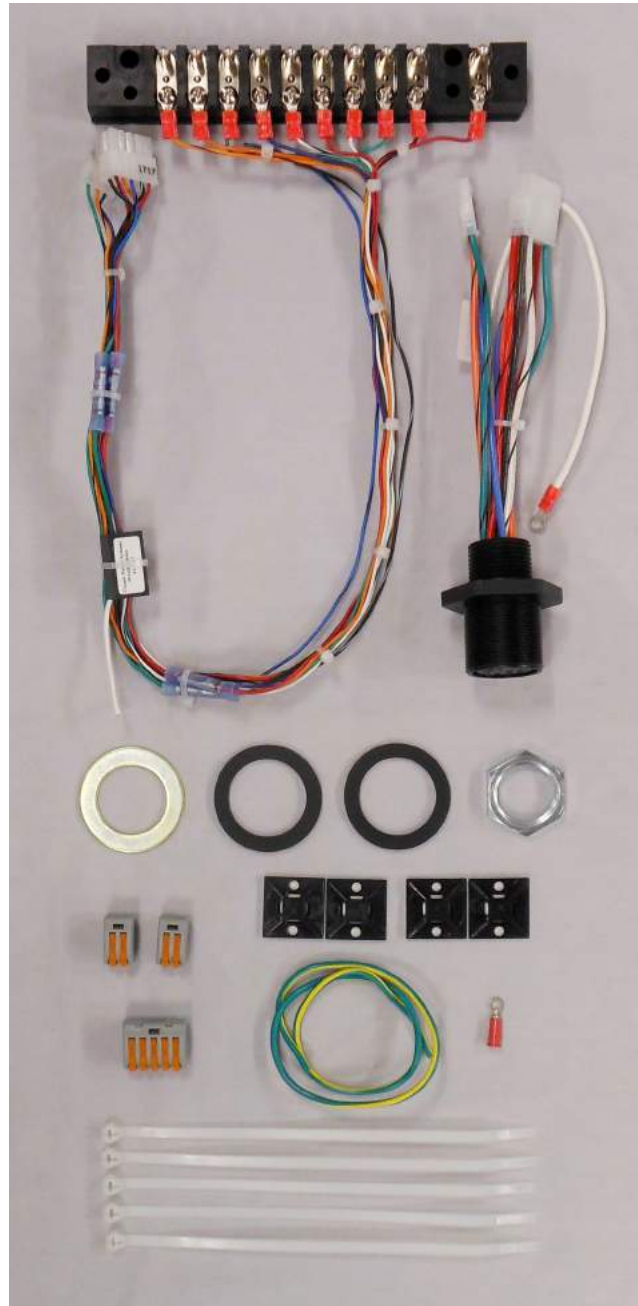

DISCLAIMER OF WARRANTIES AND LIMITATION OF LIABILITY

The information, recommendations, descriptions and safety notations in this document are based on Eaton Corporation's ("Eaton") experience and judgment and may not cover all contingencies. If further information is required, an Eaton sales office should be consulted. Sale of the product shown in this literature is subject to the terms and conditions outlined in appropriate Eaton selling policies or other contractual agreement between Eaton and the purchaser.

THERE ARE NO UNDERSTANDINGS, AGREEMENTS, WARRANTIES, EXPRESSED OR IMPLIED, INCLUDING WARRANTIES OF FITNESS FOR A PARTICULAR PURPOSE OR MERCHANTABILITY, OTHER THAN THOSE SPECIFICALLY SET OUT IN ANY EXISTING CONTRACT BETWEEN THE PARTIES. ANY SUCH CONTRACT STATES THE ENTIRE OBLIGATION OF EATON. THE CONTENTS OF THIS DOCUMENT SHALL NOT BECOME PART OF OR MODIFY ANY CONTRACT BETWEEN THE PARTIES.

In no event will Eaton be responsible to the purchaser or user in contract, in tort (including negligence), strict liability or otherwise for any special, indirect, incidental or consequential damage or loss whatsoever, including but not limited to damage or loss of use of equipment, plant or power system, cost of capital, loss of power, additional expenses in the use of existing power facilities, or claims against the purchaser or user by its customers resulting from the use of the information, recommendations and descriptions contained herein. The information contained in this manual is subject to change without notice.

Contents

DISCLAIMER OF WARRANTIES AND LIMITATION OF LIABILITY	ii
SAFETY FOR LIFE	iv
SAFETY INFORMATION	iv
Safety instructions	iv
PRODUCT INFORMATION	1
Introduction	1
Read this manual first	1
Additional information	1
Acceptance and initial inspection	1
Handling and storage	1
Quality standards	1
GENERAL	1
Kit supplied	1
Tools required	1
INSTALLATION SUMMARY	2
PREPARE CL-7 CONTROL BOX FOR INSTALLATION	3
Option 1: Multi-phase CL-7 control application	3
Option 2: Single-phase CL-7 control application	7
QCA INSTALLATION INSTRUCTIONS	10
Parts list	10
Preparation for installation	10
QCA installation	11
QCA harness terminal markings, wire colors and functions	12
Motor capacitor connections	13
Connecting the control cable and programming the control	15
APPENDIX A	16
13-conductor applications	16
APPENDIX B	17
14-conductor applications	17



Safety for life



Eaton meets or exceeds all applicable industry standards relating to product safety in its Cooper Power™ series products. We actively promote safe practices in the use and maintenance of our products through our service literature, instructional training programs, and the continuous efforts of all Eaton employees involved in product design, manufacture, marketing, and service.

We strongly urge that you always follow all locally-approved safety procedures and safety instructions when working around high-voltage lines and equipment, and support our “Safety For Life” mission.

Safety information

The instructions in this manual are not intended as a substitute for proper training or adequate experience in the safe operation of the equipment described. Only competent technicians who are familiar with this equipment should install, operate, and service it.

A competent technician has these qualifications:

- Is thoroughly familiar with these instructions.
- Is trained in industry-accepted high- and low-voltage safe operating practices and procedures.
- Is trained and authorized to energize, de-energize, clear, and ground power distribution equipment.
- Is trained in the care and use of protective equipment such as arc flash clothing, safety glasses, face shield, hard hat, rubber gloves, clampstick, hotstick, etc.

Following is important safety information. For safe installation and operation of this equipment, be sure to read and understand all cautions and warnings.

Hazard Statement Definitions

This manual may contain four types of hazard statements:

 **DANGER**

Indicates an imminently hazardous situation which, if not avoided, will result in death or serious injury.

 **WARNING**

Indicates a potentially hazardous situation which, if not avoided, could result in death or serious injury.

 **CAUTION**

Indicates a potentially hazardous situation which, if not avoided, may result in minor or moderate injury.

CAUTION

Indicates a potentially hazardous situation which, if not avoided, may result in equipment damage only.

Safety instructions

Following are general caution and warning statements that apply to this equipment. Additional statements, related to specific tasks and procedures, are located throughout the manual.

 **DANGER**

Hazardous voltage. Contact with hazardous voltage will cause death or severe personal injury. Follow all locally-approved safety procedures when working around high- and low-voltage lines and equipment.

G103.3

 **WARNING**

Before installing, operating, maintaining, or testing this equipment, carefully read and understand the contents of this manual. Improper operation, handling, or maintenance can result in death, severe personal injury, and equipment damage.

G101.0

 **WARNING**

This equipment is not intended to protect human life. Follow all locally-approved procedures and safety practices when installing or operating this equipment. Failure to comply can result in death, severe personal injury, and equipment damage.

G102.1

 **WARNING**

Power distribution and transmission equipment must be properly selected for the intended application. It must be installed and serviced by competent personnel who have been trained and understand proper safety procedures. These instructions are written for such personnel and are not a substitute for adequate training and experience in safety procedures. Failure to properly select, install, or maintain power distribution and transmission equipment can result in death, severe personal injury, and equipment damage.

G122.2

Product information

Introduction

The Quick Connect Assembly (QCA) provides the parts needed to convert a non-Cooper Power series voltage regulator control box into a junction box. After the installation of the QCA into an existing control box, a quick-connect control cable connector will exit the bottom of that box. This will create a quick connect interface with a new Eaton's Cooper Power series voltage regulator control.

The most common use of the QCA would be to install a CL-7 multi-phase control onto non-Cooper Power series voltage regulators.

These instructions describe the installation procedures for installing a QCA into a Siemens Corporation or Howard Industries step voltage regulator control box.

Read this manual first

Read and understand the contents of this manual and follow all locally approved procedures and safety practices before installing or operating this equipment.

Additional information

These instructions cannot cover all details or variations in the equipment, procedures, or process described nor provide directions for meeting every possible contingency during installation, operation, or maintenance. For additional information, contact your Eaton representative.

Acceptance and initial inspection

Each kit is in good condition when accepted by the carrier for shipment. Upon receipt, inspect the shipping container for signs of damage. Unpack the kit and inspect it thoroughly for damage incurred during shipment. If damage is discovered, file a claim with the carrier immediately.

Handling and storage

Be careful during handling and storage of the kit to minimize the possibility of damage. If the kit is to be stored for any length of time prior to installation, provide a clean, dry storage area.

Quality standards

ISO 9001 Certified Quality Management System

General

Kit supplied

The QCA kit supplied depends upon the number of conductors specified when the kit is ordered. As separate items, control cables with a matching number of conductors, a CL-7 control, and control box will be required for this installation. Here are the QCA kit part number options:

Manufacturer	Part Number	Description	Qty.
Siemens Corporation / Howard Industries	575044887B01	QCA, 12 conductor	1
	575044887B04	QCA, 13 conductor	1
	575044887B07	QCA, 14 conductor	1

Tools required

Item Number	Description	Qty.
1	Pliers	1
2	Wire Cutters	1
3	Standard Flat Head Screwdriver	1
4	Phillips #2 Screwdriver	1
5	Electric Drill	1
6	1-1/4-inch Open End Wrench	1
7	1-3/4-inch Open End Wrench	2
8	3/8-inch Socket	1
9	Hammer	1
10	Hole Saw	1
11	Chisel	1
12	Ratchet Wrench	1
13	Wire Terminal Crimper	1

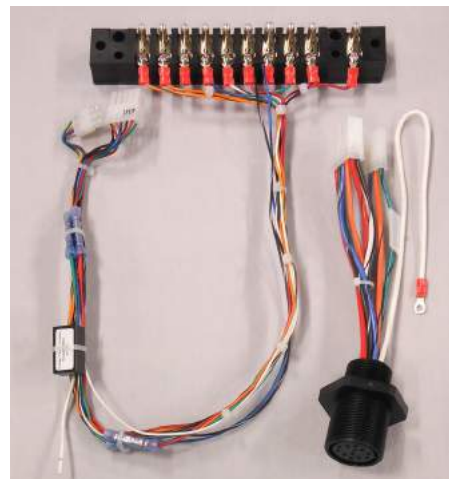

Siemens/Howard 12 conductor QCA,
from kit part# 575044887B01

Installation summary

Retrofitting a CL-7 control onto a Siemens or Howard voltage regulator using a QCA kit will require these general steps. Be sure to select the applicable options to complete each step. The general steps are:

1. Prepare the new CL-7 control box (instructions provided in this document):
 - a. Option 1: Multi-phase CL-7 control application
 - b. Option 2: Single-phase CL-7 control application
2. Mount the new CL-7 control box in a suitable location.
3. Install the QCA into the existing control box (instructions provided in this document).
4. Connect the new CL-7 control box to the existing control box using Cooper Power series quick connect cables (instructions provided in this document).
5. Program the CL-7 control (refer to document *MN225003EN, CL-7 Voltage Regulator Control Installation, Operation, and Maintenance Instructions*).

Prepare CL-7 control box for installation

Follow the steps of Option 1 when utilizing a multi-phase CL-7 control and Option 2 when utilizing a single-phase CL-7 control.

Option 1: Multi-phase CL-7 control application

Control cable installation

Note: The control cable installation steps must be performed for each control cable.

1. Remove the nut, flat washer, and gasket from the female connector of the control cable (Figure 1).

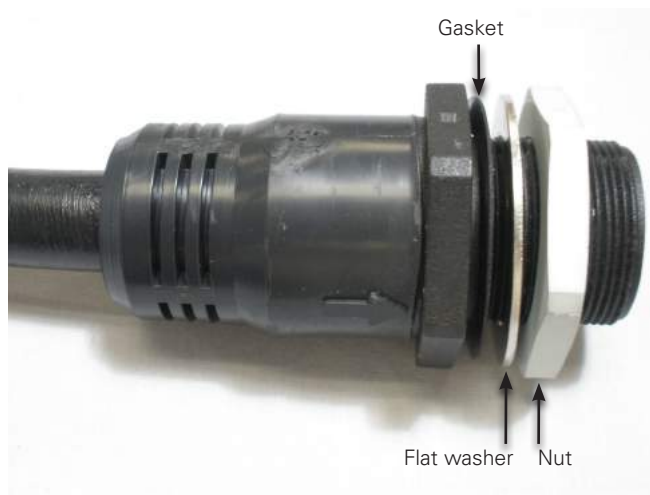

Figure 1. Control cable female connector and components.

Note: With the multi-phase control enclosure, two or three locations are required for control cable entry. The entry locations will be identified as VR1, VR2, and VR3 as shown in Figure 2. Entry locations may vary.



Figure 2. Enclosure entry way examples.

2. With the gasket located around the outside of the entry hole, insert the threaded portion of the control cable as shown in Figure 3.

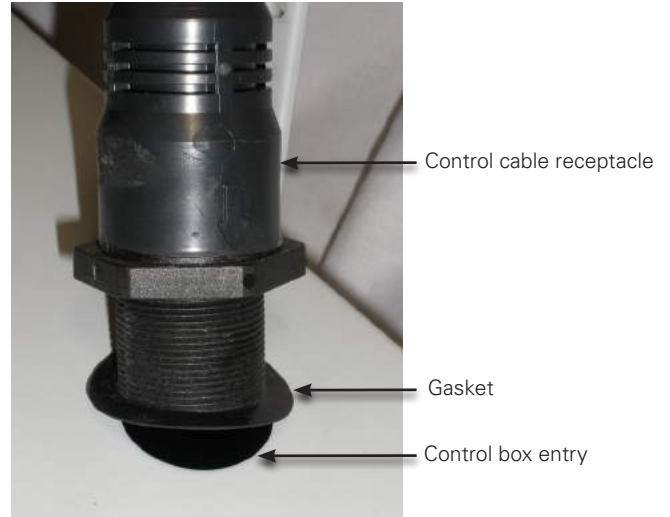

Figure 3. Installation of control cable.

3. Inside the control box, place the flat washer and nut onto the threads as shown in Figure 4. Tighten the nut snugly using a 1-3/4" open-end wrench while holding the cable receptacle on the outside of the box.

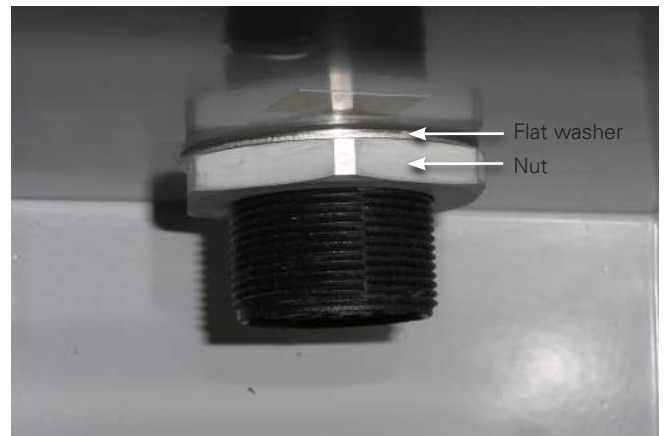

Figure 4. Securing control cable to box.

Quick Connect Assembly (QCA) Retrofit Kit, Siemens/Howard

- Identify the correct pigtail harness to be connected to the incoming control cable by matching the VR1, VR2, or VR3 labels as shown in Figure 5.



Figure 5. Coordination of control cable with pigtail harness.

- Line up the keyway with with the key of the control cable connector. See Figure 6.



Figure 6. Male pigtail harness connector.

- Push the male connector as far as possible onto the control cable connector while tightening the pigtail nut. Repeat the process of pushing on the harness connector and tightening the nut until the connection is fully tightened. A loose nut could result in cable corrosion. See Figure 7.

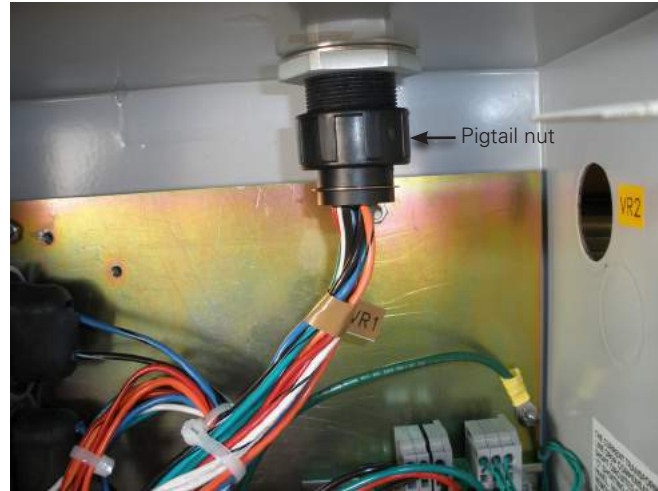

Figure 7. Installed control cable receptacle and connector assembly.

Operations counter connections

Note: These steps are required for operations counter functionality. If these steps are skipped, the motor fuses will blow when motor operation is attempted.

- On the back panel behind the CL-7 multi-phase control, identify the three orange holding switch wires as shown in Figure 8. The wires are connected as follows:
 - VR1 connected to HS
 - VR2 connected to HSB
 - VR3 connected to HSC

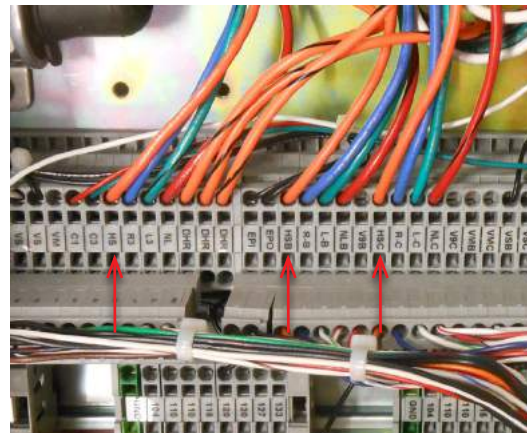

Figure 8. Identifying the orange holding switch wires.

Quick Connect Assembly (QCA) Retrofit Kit, Siemens/Howard

8. For voltage regulators that are not Cooper Power series, move the orange holding switch wires corresponding to these units as follows:

- VR1 move from HS to 5
- VR2 move from HSB to J
- VR3 move from HSC to BR

Note: For multi-phase control applications where voltage regulators from a mix of manufacturers will be connected, move only the orange wires corresponding to voltage regulators that were not manufactured by Eaton's Cooper Power Systems.

Do not move the orange wires corresponding to any Cooper Power series or McGraw Edison voltage regulators.

To move the wires, use the wire insertion tool provided in the control box and shown in Figure 9. Insert the tool into the square hole below the wire and press in firmly to release the wire. When inserting a wire into a terminal, press the tool firmly into the square hole while inserting the wire in the round hole. See Figure 10 for an illustration.

Figure 11 shows the orange wires moved for VR1 and VR2.

Note: Moving the orange wires for non-Cooper Power series voltage regulators is required for operations counter functionality. If this is not done, the motor fuse will blow when a motor operation is attempted.



Figure 11. Orange wires shown relocated for VR1 and VR2. Each non-Cooper Power series connected voltage regulator requires relocation of an orange wire.



Figure 9. Wire insertion tool.

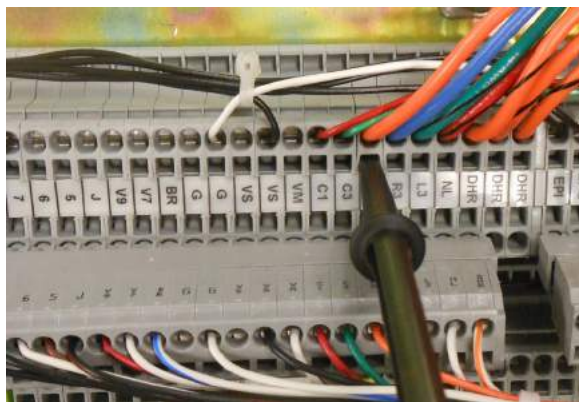

Figure 10. Using the wire insertion tool to move the orange wires.

Quick Connect Assembly (QCA) Retrofit Kit, Siemens/Howard

Motor capacitor installation

9. If the motor capacitors were installed in the Siemens/Howard control box, they may remain there or can be moved into the CL-7 control box as shown in Figures 12 and 13. If they will not be moved into the new control box, skip the steps regarding the installation of the motor capacitor.

Note: Further information is included in the QCA installation instructions for completion of the motor capacitor connections.



Figure 12. Multi-phase motor capacitor provisions.



Figure 13. Alternate motor capacitor mounting provisions.

10. Place the capacitor terminal boots over the blue/black and black/white wires from the pigtail harnesses for each phase. For the 14-conductor QCA, the capacitor wires will be colored red/white and green/white.
11. Push the blue/black and black/white wire terminals on to the respective capacitor terminals.

12. Place the protective boots over the capacitor terminals and snap them into place as shown in Figure 14.



Figure 14. Capacitor protective boots.

Neutral light source switch

13. On the left side of the CL-7 multi-phase control panel are three recessed switches (Figure 15). Make sure the switches are placed in the upward positions for most applications. If the neutral lights stays on all the time for any voltage regulator or does not come on at all, place the switch in the opposite position. The top switch is identified as VR1, the middle one is VR2, and the bottom one is VR3.

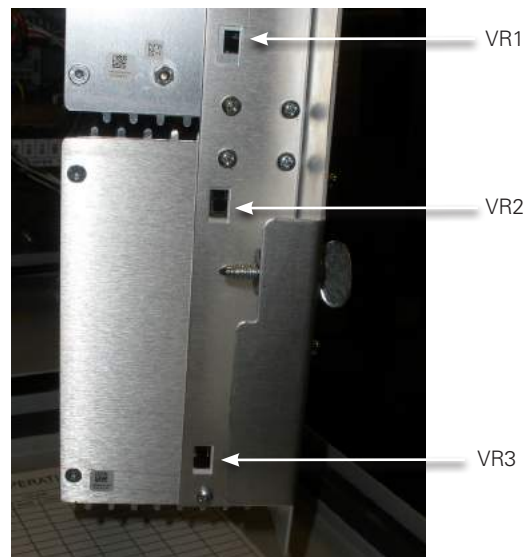

Figure 15. Multi-phase Neutral light source switches.

IMPORTANT

Proceed to the "QCA installation instructions" on page 10 of this document.

Option 2: Single-phase CL-7 control application

Control cable installation

1. Remove the nut, flat washer, and gasket from the female connector of the control cable (Figure 16).

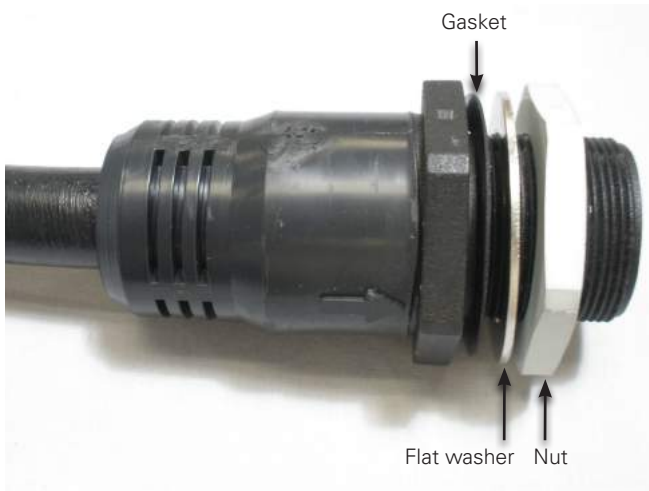

Figure 16. Control cable female connector and components.

2. With the gasket located around the outside of the entry hole, insert the threaded portion of the cable as shown in Figure 17.



Figure 17. Installation of control cable.

3. Inside the control box, place the flat washer and nut onto the threads as shown in Figure 18. Tighten the nut snugly using a 1-3/4" open-end wrench.

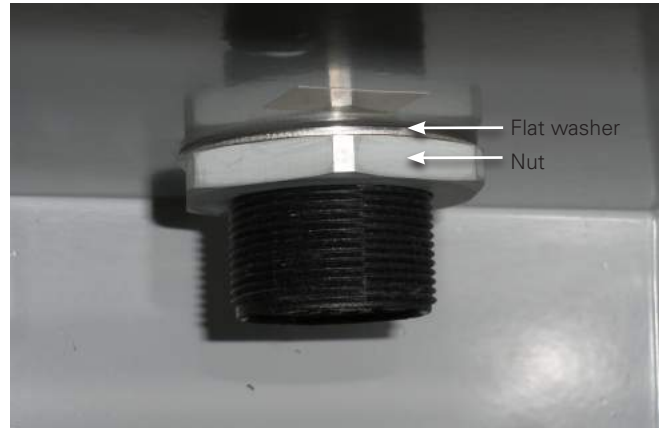

Figure 18. Securing control cable to box.

4. Locate the pigtail harness with male connector and line up the keyway with the key of the control cable connector. See Figure 19.

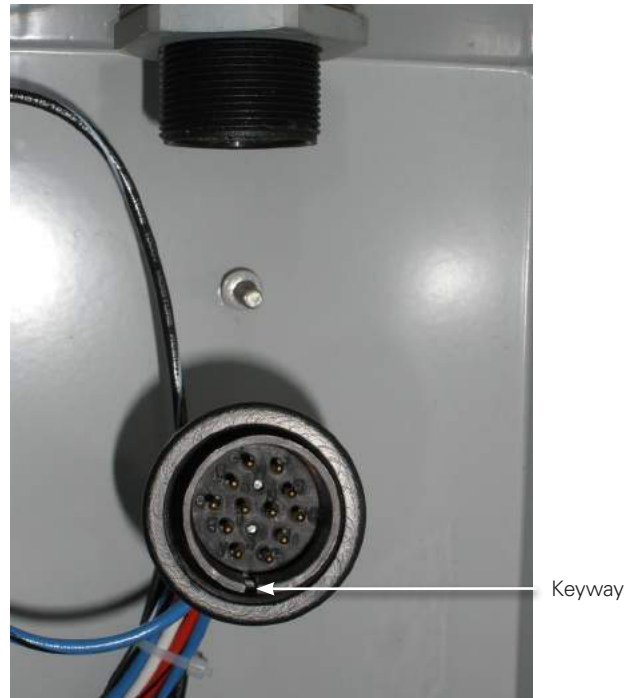

Figure 19. Male pigtail harness connector.

Quick Connect Assembly (QCA) Retrofit Kit, Siemens/Howard

5. Push the male connector as far as possible onto the control cable connector while tightening the pigtail nut. Repeat the process of pushing on the harness connector and tightening the nut until the connection is fully tightened. A loose nut could result in cable corrosion. See Figure 20.



Figure 20. Installed pigtail connector on control cable.

Operations counter connection

Note: These steps are required for operations counter functionality. If these steps are skipped, the motor fuse will blow when a motor operation is attempted.

6. Using the wire insertion tool supplied in the control box (Figure 21), remove the orange lead from the HS position of the terminal board at the bottom of the back panel shown in Figure 22. To remove the wire, insert the tool into the square hole below the wire and press in firmly to release the wire.



Figure 21. Wire insertion tool.

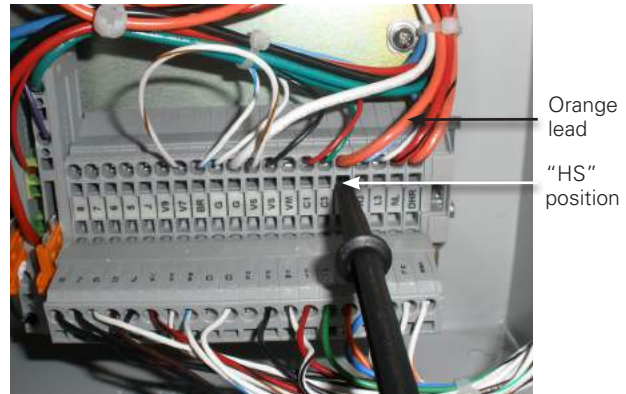

Figure 22. Removal of "HS" orange lead.

7. Reconnect the orange lead to terminal 5 using the insertion tool as shown in Figure 23. To insert a wire into a terminal, press the tool into the square hole and press in firmly while inserting the wire in the round hole.

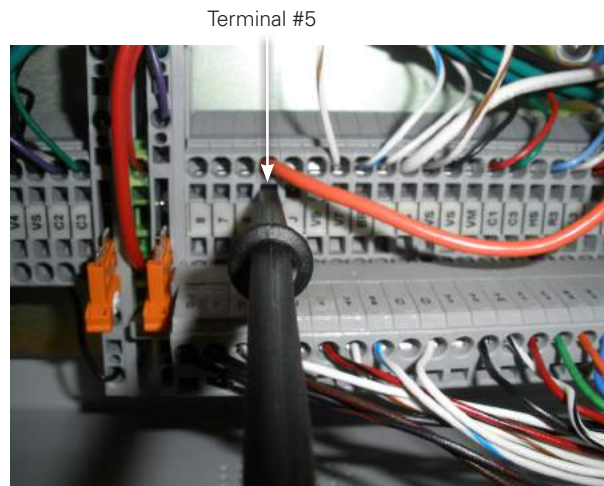

Figure 23. Relocate the orange wire to terminal 5.

Motor capacitor installation

8. If the motor capacitor was installed in the original control box, it may remain there or it can be moved into the CL-7 control box as shown in Figure 24.

Note: Further information is included in the QCA installation instructions for completion of the motor capacitor connections.



Figure 24. Motor capacitor mounting provision.

9. Place the capacitor terminal boot on to the blue/black and black/white wires from the pigtail harness. For a 14-conductor QCA, the capacitor wires will be colored red/white and green/white.
10. Push the blue/black and black/white wire terminals on to the capacitor terminals as shown in Figure 25.

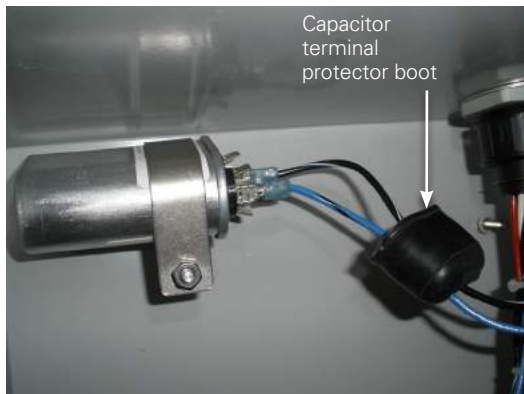

Figure 25. Motor capacitor connections.

11. Place the capacitor protective boot over the capacitor terminals and snap in place.

Neutral light source switch

12. On the bottom left side of the CL-7 Control Panel, a recessed switch (Figure 26) is to be placed in the upward position for most applications. If the neutral light stays on all the time or does not come on at all, place the switch in the opposite position.



Figure 26. Neutral light source switch.

IMPORTANT

Proceed to the "QCA installation instructions" on page 10 of this document.

QCA installation instructions

Parts list

Item	Part Number	Description	Qty.
1	5044886B01	12-conductor Siemens QCA*	1
	5044886B04	14-conductor Siemens QCA (option 2)	
2	5043000B01	12-conductor Pigtail Harness	1
	5043000B03	13-conductor Pigtail Harness (option 1)	
	5043000B02	14-conductor Pigtail Harness (option 2)	
3	08A621282001	Washer	1
4	0537980C03	Gasket	2
5	A5481751	Nut	1
6	0800011079Z	Cable Tie	5
7	0800069825Z	Adhesive Back Fastener	4
8	0793628A01	2-Position Lever Splice	2 - 4
9	0793628A02	5-Position Lever Splice	1
10	236042212	Ground-Wire, Green (Option 1)	19"
11	TAA114723003	Stud Terminal (Option 1)	1

Note: Items marked with Option 1 are used on the 13-conductor variation only, and items marked Option 2 are used on the 14-conductor variation only. The item marked with a * is used on the 12- and 13-conductor variations.

Preparation for installation

1. It is recommended that the voltage regulator be deenergized and removed from service before beginning the installation of the QCA kit. Consult the Siemens Corporation or Howard Industries documentation for recommended procedures for removing a voltage regulator from service.

DANGER

Explosion Hazard. An energized voltage regulator must not be bypassed off of the neutral position. 1) Prior to bypass switching, the voltage regulator must be placed in the neutral position. 2) Tap-changer operation must be disabled during the bypass switching to insure that it does not step off of neutral. If the regulator is in any position other than neutral while bypassing, part of the series winding will be shorted when the bypass switch is closed. This will result in high circulating current within the winding. Failure to comply will result in death or severe personal injury and equipment damage.

DANGER

Explosion Hazard. Bypass a regulator with the line energized only if the position indicator, the neutral light, and the voltage measured between the source and the load bushings using an approved voltmeter is zero. If all indications of neutral do not agree, the line should be deenergized to avoid shorting part of the series winding and resultant high circulating current. Failure to comply can result in death or personal injury and equipment damage.

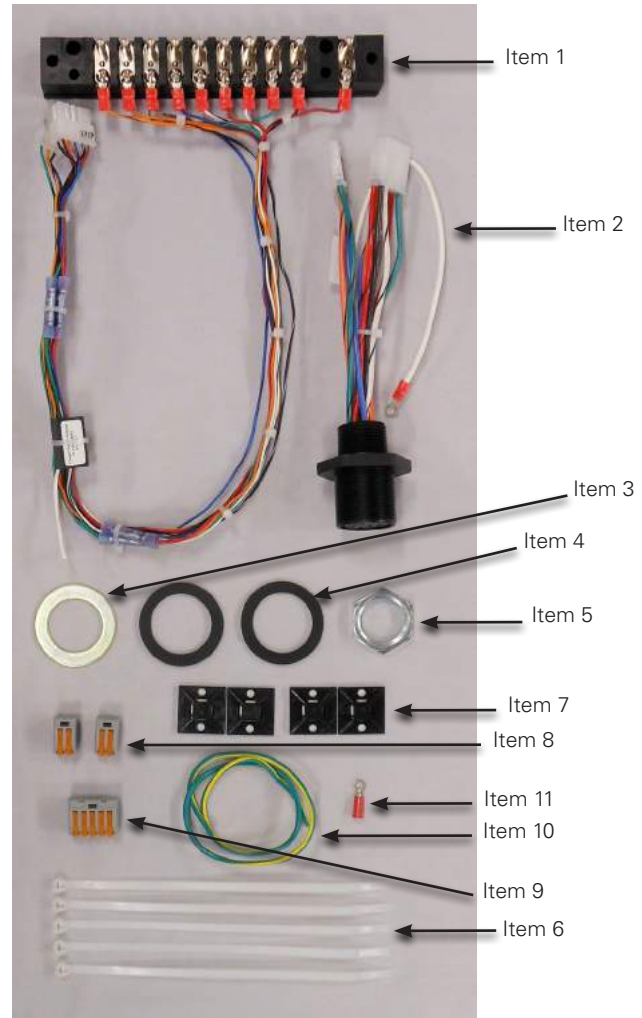

Figure 27. Siemens/Howard QCA kit.

- Remove the existing voltage regulator control from the control box leaving in place the jack-plug receptacle and wiring from the regulator to the control box. Retain the jack plug wing nuts. Consult Siemens/Howard documentation for further instructions, as required. See Figure 28.

IMPORTANT

If the existing control box location will change, move the control box to its new location, shorten the control wiring as needed, and reconnect the control wires to the jack plug receptacle before proceeding.



Jack-plug receptacle

Figure 28. Leave the jack-plug receptacle in place.

- A 1-1/8" diameter hole in the bottom of the control box is required. If there is a knockout, remove it. If a hole provision is not provided, cut a hole using a hole saw. See Figure 29.

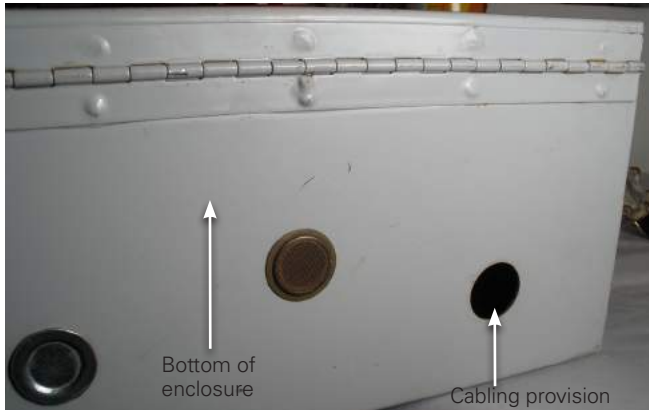

Figure 29. Control enclosure bottom access.

QCA installation

- Place one of the gaskets (Item 4), over the pigtail harness wires seating the gasket against the connector nut as shown in Figure 30

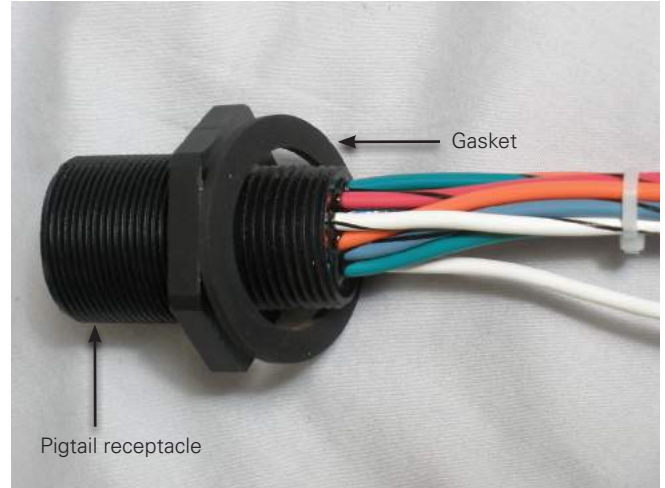

Figure 30. Gasket installed over pigtail connector.

- From outside of enclosure insert the pigtail wires through the opening at the bottom of the control enclosure and seat the gasket against the bottom of the control box. See Figure 31.



Figure 31. Installation of the pigtail into the bottom of the control box.

Quick Connect Assembly (QCA) Retrofit Kit, Siemens/Howard

6. Place the second gasket (Item 4) over the pigtail wires on the inside surface of the control box. See Figure 32.



Figure 32. Pigtail internal gasket installation.

7. Place flat washer (Item 3) and nut (Item 5) over the pigtail wires and finger-tighten the nut as shown in Figure 33.



Figure 33. Securing the pigtail with a nut and washer.

8. Secure the pigtail by tightening the nut with a 1-1/4" open-end wrench while holding the connector nut on the outside of the control box with a 1-3/4" wrench.

9. Insert the male portion of the jack plug supplied in the QCA kit into the jack plug receptacle inside of the control box and secure with the wing-nuts retained earlier. See Figure 34.

QCA harness terminal markings, wire colors and functions

Siemens Terminals	Howard Terminals	QCA Wire Colors	Functions
U12	NS	Red/Black	Neutral Light
P2	PS	Black	Load PT
C2	C	Green	CT Line
E	G	White	Ground*
E1	CO	Red	CT Ground
U2	MS	White/Black	Source PT
J	R	Blue	Raise
K	L	Green/Black	Lower
U10	DC	Orange	Ops Counter
U11	DHR	Orange/Back	Drag-hand Reset
-	-	Blue/Black	Motor Capacitor**
-	-	Black/White	Motor Capacitor**
-	-	Red/White	Motor Capacitor†
-	-	Green/White	Motor Capacitor†
-	-	Green	Cable Shield††

*QCA will have a white ground wire and a white CT protector wire.

**For the 14-conductor harness, these wires will be used for an auxiliary winding.

†14-conductor QCA only.

††13-conductor QCA only.



Figure 34. Wing nut installation.

10. Cut the ring terminal from the end of the pigtail white ground wire and strip 1/4" of insulation from the wire.
11. Strip 1/4" of insulation from the white ground wire of the jack plug wire harness.
12. Use the 5-position lever splice to connect the ground wires from the pigtail, CT protector device, and jack plug harness. See Figure 35.

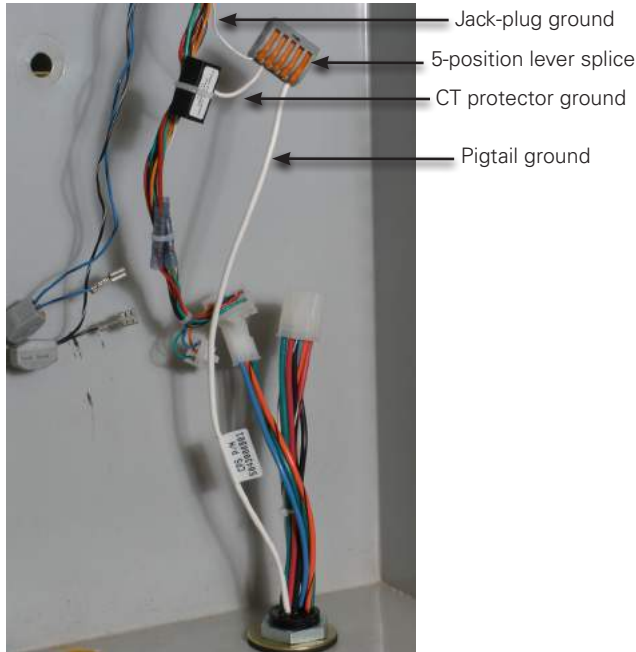

Figure 35. Connecting the three ground wires.

13. Link together the two connector plugs between the pigtail harness and the jack-plug harness as shown in Figure 36.

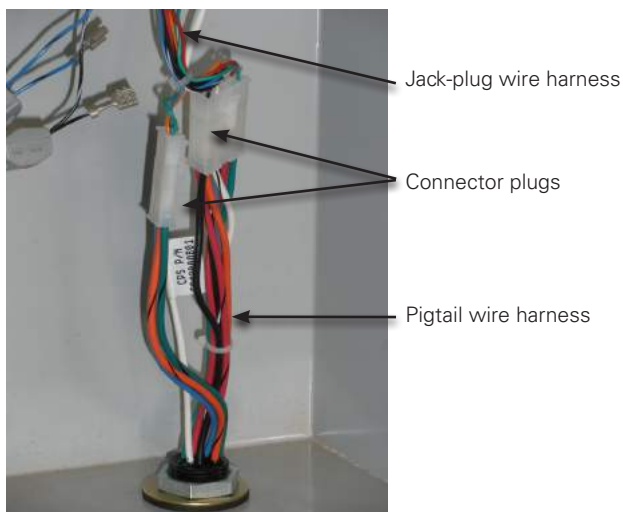

Figure 36. Connecting the jack-plug harness to the pigtail harness.

Motor capacitor connections

14. Identify the motor capacitor wires. There are two scenarios for handling the wires:

Motor capacitor scenario 1

Motor capacitor will not be moved into the new control box. If the motor capacitor is located in the tank or will remain in the original Siemens/Howard control box, the motor capacitor wires will not be used. In these cases, cap the motor capacitor wires by installing a 2-position lever splice over each wire as shown in Figure 37.

Note: On the 14-conductor QCA variation, the capacitor leads will be colored red/white and green/white.

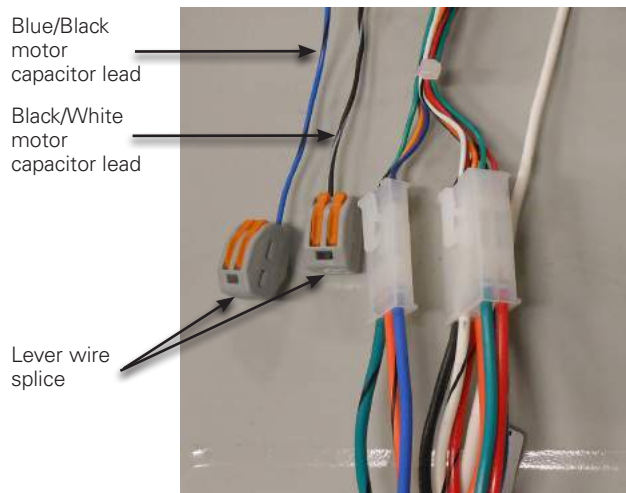

Figure 37. Capping the motor capacitor wires.

Quick Connect Assembly (QCA) Retrofit Kit, Siemens/Howard

Motor capacitor scenario 2

The motor capacitor was relocated to inside of the new Eaton's Cooper Power series control box. If the motor capacitor was moved into the new control box during the preparation of the control box, follow these steps:

- Strip 1/4" of insulation from each of the blue/black and black/white wires coming from the jack-plug wire harness.
- Remove the terminals from the motor capacitor leads coming from the electrical conduit at the top of the Siemens/Howard control box and strip back 1/4" of insulation from each of the leads.
- Using one of the 2-position lever splices, connect one capacitor lead from the conduit to either of the motor capacitor leads from the jack-plug wire harness. Repeat the connection for the remaining set of capacitor leads. See Figure 38.

Note: The polarity of the motor capacitor connections is not important.

Note: On the 14-conductor QCA variation, the capacitor leads will be colored red/white and green/white.

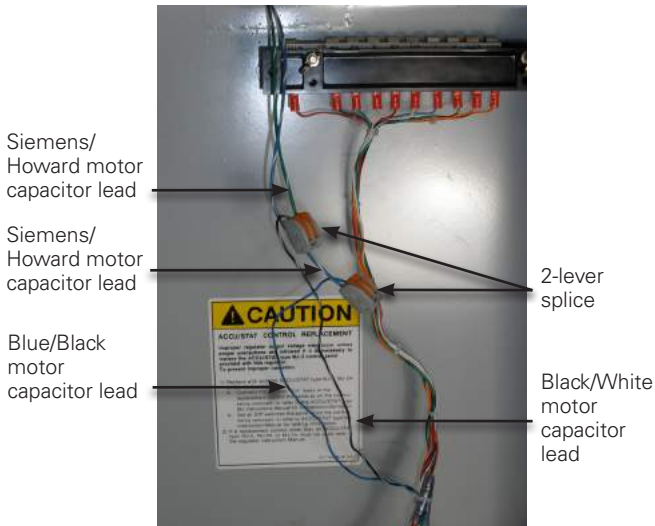

Figure 38. Siemens/Howard motor capacitor lead connections.

- Secure the QCA wires inside the Siemens/Howard control box by placing tie fasteners (Item 6) as needed and then fastening with cable ties as shown in Figure 39.

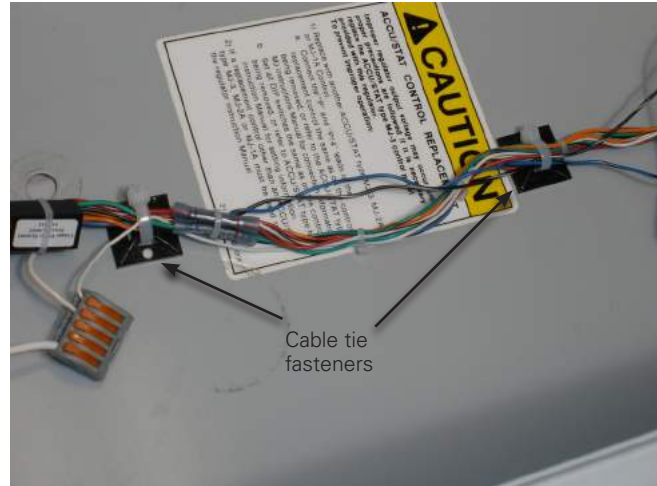

Figure 39. Secured QCA harness assembly.

IMPORTANT

Review "Appendix A" on page 16 for a 13-conductor QCA application and "Appendix B" on page 17 for a 14-conductor QCA application.

Connecting the control cable and programming the control

16. Connect the control cable (previously installed) from the new control box to QCA connector at the bottom of the existing Siemens/Howard control box. See Figures 40 and 41.



Figure 40. QCA connector coming from the bottom of the Siemens/Howard control box.



Figure 41. Making the final connection to the QCA.

17. While making the control cable connection, be sure to push the connector on as far as it will go and then tighten the nut. Repeatedly push on the connector and tighten the nut until the connection is fully tightened.

Note: A loose nut could result in cable corrosion.

18. When all the QCA installation work is completed, return the voltage regulators to service. Refer to the documentation provided by Siemens/Howard for information pertaining to their equipment.

19. Refer to document *MN225003EN, CL-7 Voltage Regulator Control Installation, Operation, and Maintenance Instructions* for more information on programming the CL-7 control.

Note: Make sure to program the control for a Siemens or Howard voltage regulator at FC 49.

Appendix A

13-conductor applications

The pigtail wire harness will include a green/yellow wire used for the cable shielding. Assemble the shielding wire as shown in Figure 42. To complete the cable shielding, the terminal should be connected to any ground point in the control box. See Figure 43 for an example of ground point connection.

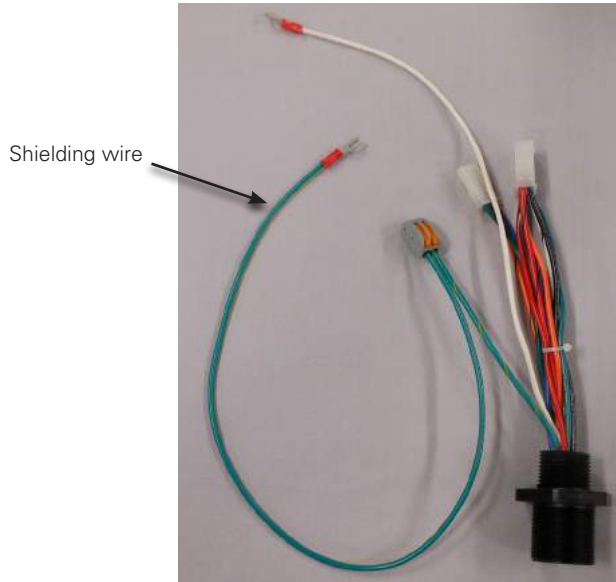

Figure 42. Pigtail harness with green/yellow shielding wire.

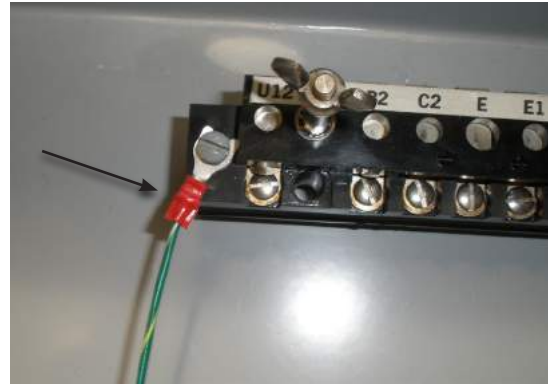

Figure 43. Connecting the shielding wire, Siemens and Howard.

Appendix B

14-conductor applications

There are two differences between the 14-conductor and 12-conductor applications as follows:

1. The motor capacitor wires in the jack-plug harness will be green/white and red/white.
2. The blue/black and black/white wires are to be used for connecting an auxiliary winding. Use two of the 2-terminal lever splices to connect the auxiliary winding leads from the Siemens/Howard voltage regulators to these wires.



Eaton
1000 Eaton Boulevard
Cleveland, OH 44122
United States
Eaton.com

Eaton's Power Systems Division
2300 Badger Drive
Waukesha, WI 53188
United States
Eaton.com/cooperpowerseries

EATON
Powering Business Worldwide

© 2017 Eaton
All Rights Reserved
Printed in USA
Publication No. MN225002EN
July 2017

Eaton is a registered trademark.

All trademarks are property of their respective owners.

For Eaton's Cooper Power series product information, call 1-877-277-4636 or visit: www.eaton.com/cooperpowerseries.