

PowerXL™

DC1...E1 Variable Frequency Drives
PI Controller



Level 3	<p>1 – Fundamental – No previous experience necessary</p> <p>2 – Basic – Basic knowledge recommended</p> <p>3 – Advanced – Reasonable knowledge required</p> <p>4 – Expert – Good experience recommended</p>
---------	--

Contents

1	General	5
2	Controller Topology.....	6
2.1	ProcessDataAccess (P-12).....	6
3	Terminal configuration.....	7
4	Connection of transducers	8
5	Analog Inputs.....	9
5.1	Analog Input 1 (AI1 Signal Range (P-16), AI1 Gain (P-35), AI1 Offset (P-39)).....	9
5.2	Analog Input 2 (AI2 Signal Range (P-47)).....	10
6	Set Point	11
6.1	PID1 Set Point 1 Source (P-44), PID1 Set Point Digital (P-45).....	11
7	Feedback	11
7.1	PID1 Mode (P-43), PID1 Feedback 1 Source (P-46).....	11
8	Gain / Time Constant.....	12
8.1	PID1 Kp (P-41), PID1 Ti (P-42).....	12
9	Standby Mode	12
9.1	t-Standby (P-48), PID1 WakeUpLevel (P-49)	12
10	Examples for the application of the PI controller	13
10.1	Example 1: Setting the internal digital set point with P-45.....	13
10.2	Example 2: Combinations of Terminals / Set Point Source / Manual-Auto / External Fault. 13	
10.3	Example 3: Simple pressure control with digital set point, direct mode	14
10.4	Example 4: Variable set point, direct mode	15
10.5	Example 5: Supply fan / compressor with pressure feedback, direct mode.....	16
10.6	Example 6: Supply fan, temperature control, inverse mode	17

Danger! - Dangerous electrical voltage!

- Disconnect the power supply of the device.
- Ensure that devices cannot be accidentally restarted.
- Verify isolation from the supply.
- Cover or enclose any adjacent live components.
- Follow the engineering instructions (AWA/IL) for the device concerned.
- Only suitably qualified personnel in accordance with EN 50110-1/-2 (VDE 0105 Part 100) may work on this device/system.
- Before installation and before touching the device ensure that you are free of electrostatic charge.
- The functional earth (FE, PES) must be connected to the protective earth (PE) or the potential equalization. The system installer is responsible for implementing this connection.
- Connecting cables and signal lines should be installed so that inductive or capacitive interference does not impair the automatic control functions.
- Suitable safety hardware and software measures should be implemented for the I/O interface so that an open circuit on the signal side does not result in undefined states.
- Deviations of the mains voltage from the rated value must not exceed the tolerance limits given in the specification, otherwise this may cause malfunction and/or dangerous operation.
- Emergency stop devices complying with IEC/EN 60204-1 must be effective in all operating modes. Unlatching of the emergency-stop devices must not cause a restart.
- Devices that are designed for mounting in housings or control cabinets must only be operated and controlled after they have been properly installed and with the housing closed.
- Wherever faults may cause injury or material damage, external measures must be implemented to ensure a safe operating state in the event of a fault or malfunction (e.g. by means of separate limit switches, mechanical interlocks etc.).
- Frequency inverters may have hot surfaces during and immediately after operation.
- Removal of the required covers, improper installation or incorrect operation of motor or frequency inverter may destroy the device and may lead to serious injury or damage.
- The applicable national safety regulations and accident prevention recommendations must be applied to all work carried on live frequency inverters.
- The electrical installation must be carried out in accordance with the relevant electrical regulations (e. g. with regard to cable cross sections, fuses, PE).
- Transport, installation, commissioning and maintenance work must be carried out only by qualified personnel (IEC 60364, HD 384 and national occupational safety regulations).
- Installations containing frequency inverters must be provided with additional monitoring and protective devices in accordance with the applicable safety regulations. Modifications to the frequency inverters using the operating software are permitted.
- All covers and doors must be kept closed during operation.
- To reduce the hazards for people or equipment, the user must include in the machine design measures that restrict the consequences of a malfunction or failure of the frequency inverter (increased motor speed or sudden standstill of motor). These measures include: – Other independent devices for monitoring safety related variables (speed, travel, end positions etc.). – Electrical or non-electrical system-wide measures (electrical or mechanical interlocks). – Never touch live parts or cable connections of the frequency inverter after it has been disconnected from the power supply. Due to the charge in the capacitors, these parts may still be alive after disconnection. Consider appropriate warning signs.

Disclaimer

The information, recommendations, descriptions, and safety notations in this document are based on Eaton's experience and judgment and may not cover all contingencies. If further information is required, an Eaton sales office should be consulted. Sale of the product shown in this literature is subject to the terms and conditions outlined in the applicable Terms and Conditions for Sale of Eaton or other contractual agreement between Eaton and the purchaser. THERE ARE NO UNDERSTANDINGS, AGREEMENTS, WARRANTIES, EXPRESSED OR IMPLIED, INCLUDING WARRANTIES OF FITNESS FOR A PARTICULAR PURPOSE OR MERCHANTABILITY, OTHER THAN THOSE SPECIFICALLY SET OUT IN ANY EXISTING CONTRACT BETWEEN THE PARTIES. ANY SUCH CONTRACT STATES THE ENTIRE OBLIGATION OF EATON. THE CONTENTS OF THIS DOCUMENT SHALL NOT BECOME PART OF OR MODIFY ANY CONTRACT BETWEEN THE PARTIES. As far as applicable mandatory law allows so, in no event will Eaton be responsible to the purchaser or user in contract, in tort (including negligence), strict liability, or otherwise for any special, indirect, incidental, or consequential damage or loss whatsoever, including but not limited to damage or loss of use of equipment, plant or power system, cost of capital, loss of power, additional expenses in the use of existing power facilities, or claims against the purchaser or user by its customers resulting from the use of the information, recommendations, and descriptions contained herein. The information contained in this manual is subject to change without notice.

1 General

Variable Frequency Drives of the series **PowerXL™ DC1...E1** have an internal PI controller, which enables the control of the motor speed depending on process variables like pressure or temperature.

General structure:

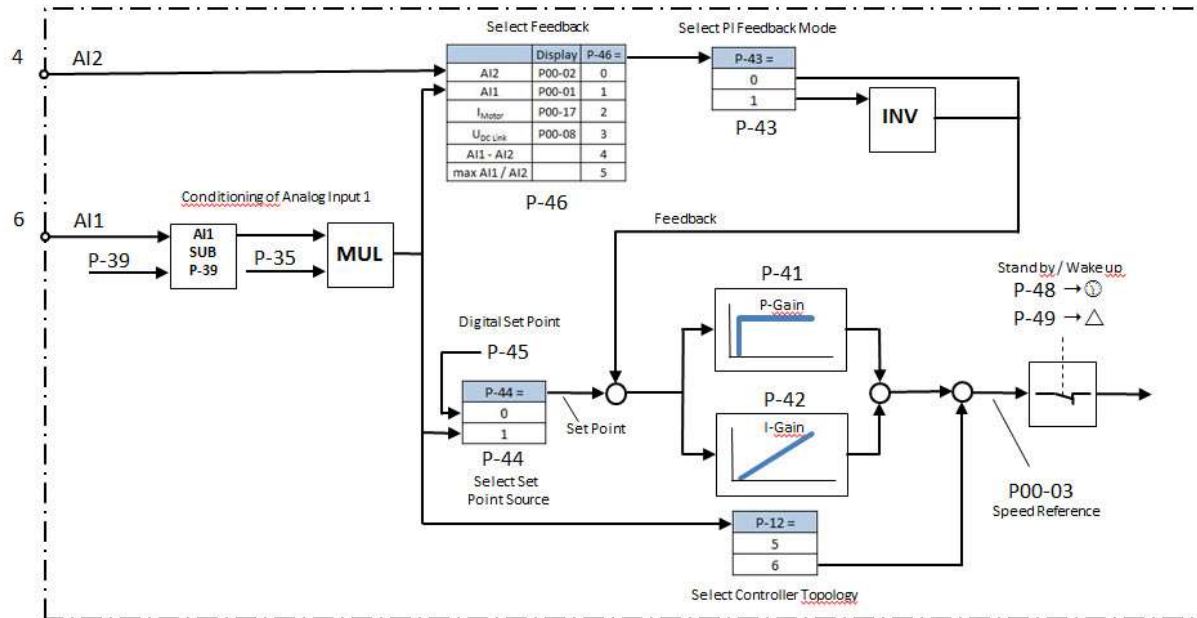

This Application Note describes

- the function of the specific parameters
- the mode of operation
- application examples

Some required parameters are inside Level 2 of the menu. This level has to be activated by prompting the „Password Level2“ (P-37) into P-14 (Password). Password Level2 is „101“ by default.

2 Controller Topology

To operate the PI controller a selection with Parameter P-12 is necessary.

2.1 ProcessDataAccess (P-12)

The PI controller operates with the settings P-12 = 5 and P-12 = 6. The setting determines the topology. It depends on the application.

P-12 = 5 → The output signal of the PI controller is the speed reference for the motor.

P-12 = 6 → The output signal of the PI controller is a correction value and is added to the value coming from the Analog Input 1 (AI1).

PNU	Parameter	Name	Range	Default
311.0	P-12	ProcessDataAccess	0: Terminal control 1: digital reference, 1 direction 2: digital reference, 2 directions 3: Modbus RTU 4: Modbus RTU with ramps 5: PI controller reference 6: PI controller correction value 7: CANopen, internal ramp 8: CANopen, ramp via CAN 9: SWD control + reference 10: SWD control 11: SWD reference 12: not allowed 13: SWD control + reference, enable	0

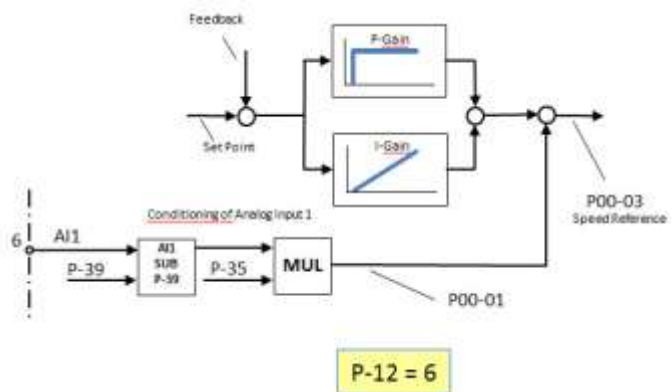
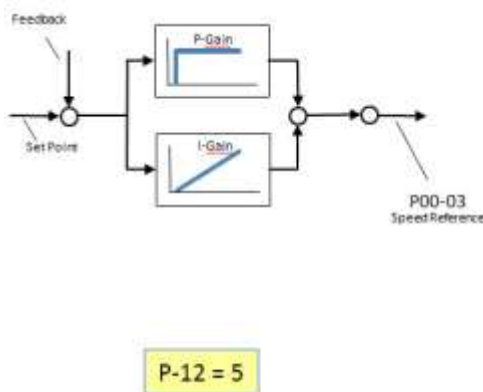

3 Terminal configuration

The configuration of the terminals can be selected with P-15 "DI Config Select" out of predefined sets. The assignment changes with the setting of P-12. For PI controller operation the configuration is as follows:

P-12 = 5: PI-Controller = Speed reference				
P-12 = 6: PI Controller = Correction value				
P-15	DI1 (Terminal 2)	DI2 (Terminal 3)	DI3/AI2 (Terminal 4)	DI4/AI1 (Terminal 6)
0	FWD	Select PI REF / f-Fix1	PI Feedback	no function
1	FWD	Select PI REF / AI1 REF	PI Feedback	AI1 REF
2	not allowed			
3	FWD	Select PI REF / f-Fix1	EXTFLT	PI Feedback
4	not allowed			
5	not allowed			
6	not allowed			
7	not allowed			
8	not allowed			
9	not allowed			
10	not allowed			
11	not allowed			
12	not allowed			
13	not allowed			
14	not allowed			
15	FWD	Select f-Fix4 / PI REF	Select Fire Mode / Normal OP	no function
16	FWD	Select f-Fix4 / f-Fix2	Select Fire Mode / Normal OP	no function
17	FWD	Select f-Fix2 / f-Fix4	Select Fire Mode / Normal OP	no function

With P-15 = 16 or 17 the fixed frequencies f-Fix2 and f_fix4 are only active in Fire Mode.

AI1 REF	The signal at Analog Input AI1 (Terminal 6) is used as set point value. P-16: Configuration (voltage input / current input ...) P-35: Scaling P-39: Offset
EXTFLT	External fault. Enables the inclusion of an external signal into the fault messages of the drive. During operation a High signal has to be present at the terminal. A Low signal leads to a trip of the drive with the message „E-trip“.
FWD	START of the drive (FWD = Forward). With a high signal at the respective terminal the drive accelerates with the ramp set with P-03. A disconnection if the signal leads to standstill . The behavior depends on the setting of P-05 (Stop Mode). At standstill the drive is disabled.
PI Feedback	Feedback signal of the PI controller, when selected with P-46.
Select f-Fix2 / f-Fix4	Selection between references Low = f-Fix2 (P21), High = f-Fix4 (P-23)
Select f-Fix4 / f-Fix 2	Selection between references Low = f-Fix4 (P23), High = f-Fix2 (P-21)
Select f-Fix4 / PI REF	Selection between references Low = f-Fix4 (P23), High = Reference from Pi controller output
Select Fire Mode / Normal OP	Selection between modes of operation Low = Fire Mode, High = normal operation
Select PI REF / AI1 REF	Selection between references. Low = Reference from Pi controller output, High = AI1
Select PI REF / f-Fix1	Selection between references. Low = Reference from Pi controller output, High = f-Fix1, set with P-20

4 Connection of transducers

The connection of analog transducers has to be done according the drawings below.

Internal burden for a current signal: 500 Ω

In case the transducer is supplied from the drive it has to be noted, that the transducer is rated for a 24 V supply.

The terminal, to which the transducer is connected, depends on the terminal configuration

P-15 = 0 or 1 → Terminal 4 (AI2)

P-15 = 3 → Terminal 6 (AI1)

Kind of transducer	Connection
2 wire transducer Supply from DC1...E1	
3 wire transducer Supply from DC1...E1	
2 wire transducer External supply	
3 wire transducer External supply	

5 Analog Inputs

Depending on the selected terminal configuration, up to two analog inputs are available. They are used as feedback input and, in case of P-15 = 1, for the connection of the speed reference which can be used as an alternative to the PI controller. Both inputs can be adapted to the format (voltage or current) of the connected signal.

5.1 Analog Input 1 (AI1 Signal Range (P-16), AI1 Gain (P-35), AI1 Offset (P-39))

At Analog Input 1 (AI1, Terminal 6) it is possible to scale the input signal and to consider an offset. This can be used to adapt the feedback signal to the transducer.

- P-16: Selection of the kind of signal at Analog Input 1. The maximum value of the signal corresponds to the maximum speed / frequency set with P-01.
- P-35: With the gain the analog input can be scaled. The gain applies to the value at AI1 as well as to the offset.
- P-39: Offset of the analog input. 100.0 % corresponds to the maximum speed / frequency set with P-01.
 - ATTENTION: the offset is subtracted from the value at terminal 6. Means: positive values for P-39 result in a reduction, negative ones in an increase.

PNU	Parameter	Name	Range	Default
260.0	P-16	AI1 Signal Range	0: 0 ... 10 V (<i>U 0-10</i>) 1 : bipolar 0 ... 10 V (<i>- 10- 10</i>) 2: 0 ... 20 mA (<i>A 0-20</i>) 3: t 4 ... 20 mA (trip in case of wire break) (<i>t 4-20</i>) 4: r 4 ... 20 mA (ramps to f-Fix1 (P-20) in case of wire break) (<i>r 4-20</i>) 5: t 20 ... 4 mA (trip in case of wire break) (<i>t 20-4</i>) 6: r 20 ... 4 mA (ramps to f-Fix1 (P-20) in case of wire break)) (<i>r 20-4</i>)	0
261.0	P-35	AI1 Gain	0.0 ... 2000.0 %	100.0 %
262.0	P-39	AI1 Offset	-500.0 % ... + 500.0 %	0.0 %

5.2 Analog Input 2 (AI2 Signal Range (P-47))

PNU	Parameter	Name	Range	Default
260.1	P-47	AI2 Signal Range	0: 0 ... 10 V (U 0-10) 1: 0 ... 20 mA (R 0-20) 2: t 4 ... 20 mA (trip in case of wire break) (t 4-20) 3: r 4 ... 20 mA (ramps to f-Fix1 (P-20) in case of wire break)) (r 4-20) 4: t 20 ... 4 mA (trip in case of wire break) (t 20-4) 5: r 20 ... 4 mA (ramps to f-Fix1 (P-20) in case of wire break)) (r 20-4) 6: Thermistor (Ptc-th)	0

6 Set Point

There are two possibilities to indicate the set point value

- with Parameter P-45 (PID1 Set Point Digital) as a fixed value. 100.0 % corresponds to the maximum value of the feedback signal.
- via analog input AI1, taking scaling and offset into account.

Selection with Parameter P-44 (PID1 Set Point 1 Source)

6.1 PID1 Set Point 1 Source (P-44), PID1 Set Point Digital (P-45)

PNU	Parameter	Name	Range	Default
2110.0	P-44	PID1 Set Point 1 Source	0: digital set point, set with P-45 1: Analog Input 1	0
2111.0	P-45	PID1 Set Point Digital	Digital set point of the PI controller in case P-44 = 0 0.0 ... 100.0 %	0.0 %

7 Feedback

It is possible to use values coming from analog transducers as well as internal ones, e.g. motor current. The feedback source is selected with P-46 (PID1 Feedback 1 Source). In addition it is possible to select with P-43 (PID1 Mode), if an increase of the feedback signal leads to a reduction of the speed (direct mode) or to an increase (inverse mode). See examples.

7.1 PID1 Mode (P-43), PID1 Feedback 1 Source (P-46)

PNU	Parameter	Name	Range	Default
2123.0	P-43	PID1 Mode	0: direct mode (0 % after Standby) 1: inverse mode (0 % after Standby) 2: direct mode (100 % after Standby) 3: inverse mode (100 % after Standby)	0
2112.0	P-46	PID1 Feedback 1 Source	0: Analog Input 2 (AI2, Kl. 4) 1: Analog Input 1 (AI1, Kl. 6) 2: Motor current 3: DC link voltage ¹⁾ 4: Difference AI1 – AI2 ²⁾ 5: max. value of AI1 and AI2	0

¹⁾ 0 ... 1000 V = 0 ... 100 %

²⁾ downwards the value is limited to zero

8 Gain / Time Constant

8.1 PID1 Kp (P-41), PID1 Ti (P-42)

The proportional gain Kp is set with P-41. Higher values provide a greater change in the drive output frequency in response to small changes in the feedback signal. Too high values can cause instability.

The integral time constant Ti is set with P-42. Larger values provide a more damped response for systems where the overall process responds slowly.

PNU	Parameter	Name	Range	Default
2100.0	P-41	PID1 Kp	0.0 ... 30.0	1.0
2101.0	P-42	PID1 Ti	0.0 ... 30.0 s	1.0 s

The right values for P-41 and P-42 have to be evaluated during commissioning, because they strongly depend on the application. Inertias and time constants play an important role.

9 Standby Mode

In some applications it is not necessary to run the motor all the time. The devices of the series DC1...E1 have the possibility, to disable the inverter output after a certain time and to activate it again when a defined control deviation (difference between set point and feedback signal) is exceeded. During standby mode is **Stndby** displayed.

9.1 t-Standby (P-48), PID1 WakeUpLevel (P-49)

Parameter P-48 (t-Standby) defines the time, after which the standby mode is activated, when the speed reference (P00-03) is equal to the minimum frequency, set with P-02. The drive will be reactivated as soon as the threshold, set with P-49, is exceeded. P-43 determines, if the controller starts with 0 % or 100 % of its output signal when quitting the standby mode. P-48 = 0.0 disables the standby mode.

P-49 determines the control deviation at which the drive recovers from standby mode.

PNU	Parameter	Name	Range	Default
331.0	P-48	t-Standby	0.0 ... 25.0 s	0.0 s
2131.0	P-49	PID1 WakeUpLevel	0.0 ... 100.0 %	0.0 %

- Activation of the standby mode:
 - Speed reference (P00-03) is equal to f-min (P-02) for the time, specified by P-48. → PI controller output is set to zero and the inverter is disabled.
- Return to normal operation:
 - Control deviation is greater than P-49 → PI controller starts to work → Activation of the inverter output, when the speed reference (P00-03) is at least equal to f-min (P-02).

10 Examples for the application of the PI controller

10.1 Example 1: Setting the internal digital set point with P-45

In a simple system, where only one set point value is necessary, the set point can be calculated based on the data of the feedback transducer.

- Required pressure: 1.5 bar
- Pressure transducer: 0 ... 5 bar corresponds to 0 ... 10 V

$$P-45 = \frac{1.5 \text{ bar}}{5 \text{ bar}} \cdot 100 \% = 30.0 \%$$

10.2 Example 2: Combinations of Terminals / Set Point Source / Manual-Auto / External Fault

The table below shows the possible combinations of terminal configuration, set point source and manual / auto operation. The term “auto” is used, when the speed reference is provided from the PI controller output. “Manual” means, that the speed is not depending on the PI set point, but on the fixed frequency (f-Fix1) or on an analog value at AI1. A digital command at DI2 (terminal 3) determines the changeover between manual and auto operation

DI configuration selection (P-15)	Set point Auto	Manual / Auto changeover	External fault EXTFLT
0	Digital (P-45) P44 = 0	DI2 = Low → Auto DI2 = High → Manual (f-Fix1)	-
1	Digital (P-45) P44 = 0	DI2 = Low → Auto DI2 = High → Manual (AI1)	-
1	Analog (AI1) P44 = 1	DI2 = Low → Auto DI2 = High → Manual (AI1) ¹⁾	-
3 ²⁾	Digital (P-45) P44 = 0	DI2 = Low → Auto DI2 = High → Manual (f-Fix1)	DI3 = Low → Fault DI3 = High → No fault

¹⁾ ATTENTION: The set point for “Auto” as well as the one for “Manual” is coming from AI1!

²⁾ ATTENTION: With P-15 = 3, P-46 (PID1 Feedback 1 Source) may only have the values 1, 2 or 3!

10.3 Example 3: Simple pressure control with digital set point, direct mode

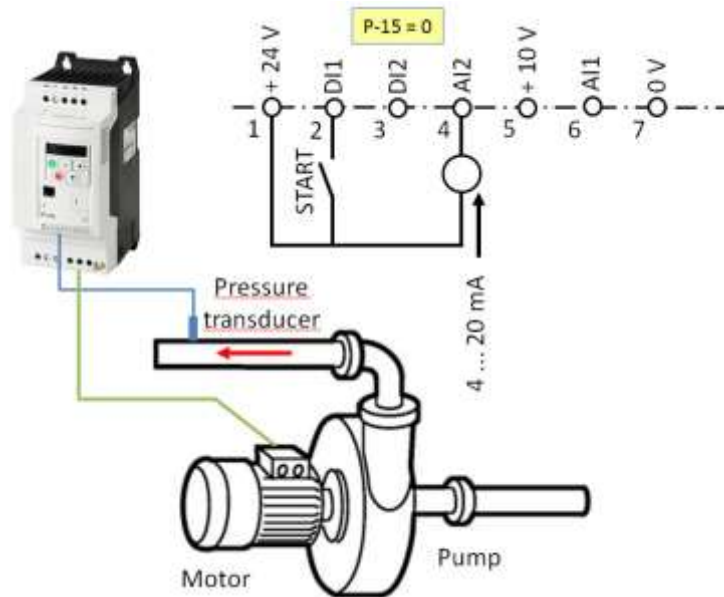

For a simple pressure control, where the set point is always fixed, the following parameters have to be modified compared to default.

Parameter	Name	Value	Remark
P-03	t-acc	10 ... 30 s	Allows smooth starting and stopping of the system
P-04	t-dec	10 ... 30 s	
P-06	EnergyOptimizer	1	Energy optimizer enabled. Because of the square pump curve, energy savings can be expected.
P-07	Motor Nom Voltage	...	Enter motor data
P-08	Motor Nom Current	...	
P-09	Motor Nom Frequency	...	
P-12	ProcessDataAccess	5	Selection of the control mode
P-14	Password	101	Allows access to Level 2 of the menu
P-41	PID1 Kp	0.5 ... 2	Gain and time constant are system dependent.
P-42	PID1 Ti	1 ... 5 s	
P-43	PID1 Mode	0	Direct mode
P-44	PID1 Set Point 1 Source	0	Selection of the digital set point, set with P-45
P-45	PID1 Set Point Digital	...	Enter the necessary value, see also example 1
P-47	AI2 Signal Range	2 (4...20 mA)	Adaptation of Analog Input 2 to the signal of the pressure transducer (4...20 mA)

10.4 Example 4: Variable set point, direct mode

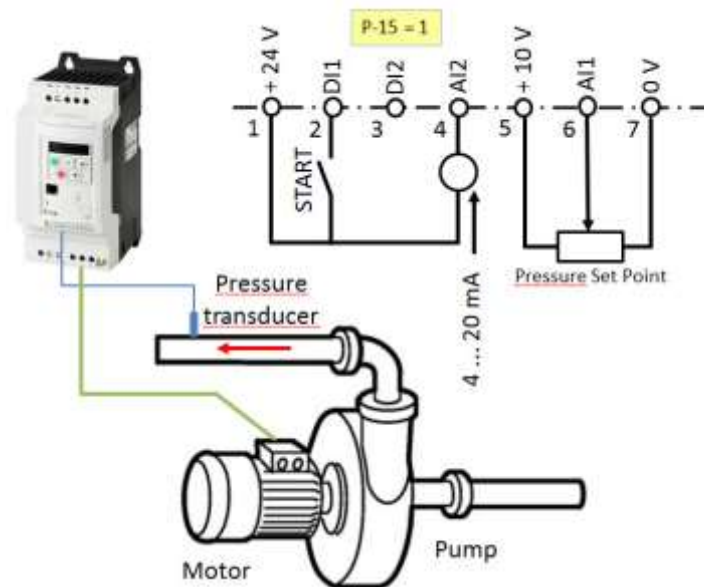

The pressure set point can be set with a potentiometer. If the set point value should not cover the complete range of the pressure transducer (e.g. pressure transducer 0 ... 10 bar, range 6 ... 8 bar), an adaptation can be done with P-39 for an offset and P-35 for scaling. The following parameters have to be modified compared to default.

Parameter	Name	Value	Remark
P-03	t-acc	10 ... 30 s	Allows smooth starting and stopping of the system
P-04	t-dec	10 ... 30 s	
P-06	EnergyOptimizer	1	Energy optimizer enabled. Because of the square pump curve, energy savings can be expected.
P-07	Motor Nom Voltage	...	Enter motor data
P-08	Motor Nom Current	...	
P-09	Motor Nom Frequency	...	
P-12	ProcessDataAccess	5	Selection of the control mode
P-14	Password	101	Allows access to Level 2 of the menu
P-15	DI Config Select	1	Selection of the terminal configuration
P-35	AI1 Gain	...	Adaptation to the sensor signal, if required
P-39	AI1 Offset	...	
P-41	PID1 Kp	0.5 ... 2	Gain and time constant are system dependent.
P-42	PID1 Ti	1 ... 5 s	
P-43	PID1 Mode	0	Direct mode
P-44	PID1 Set Point 1 Source	1	Selection of the analog set point at AI1
P-47	AI2 Signal Range	2 (4...20 mA)	Adaptation of Analog Input 2 to the signal of the pressure transducer (4...20 mA)

10.5 Example 5: Supply fan / compressor with pressure feedback, direct mode

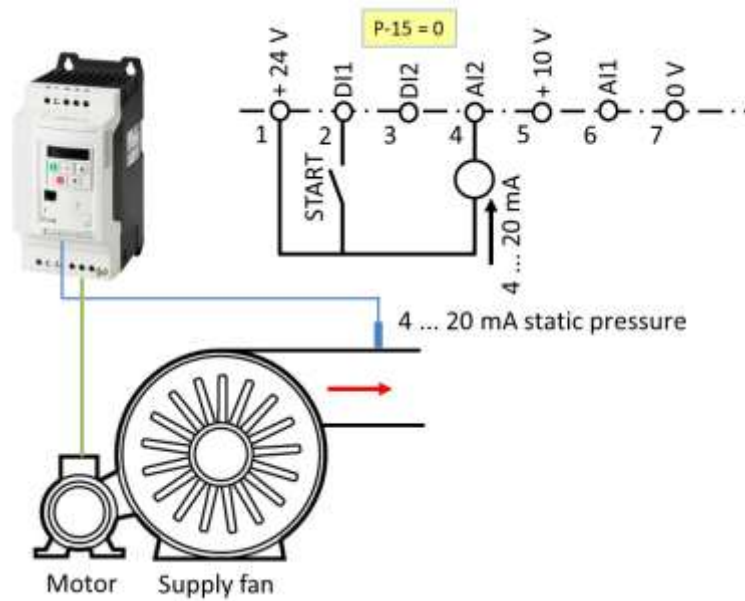

The fixed pressure set point is defined by P-45. The pressure increases with increasing speed → direct mode. The following parameters have to be modified compared to default.

Parameter	Name	Value	Remark
P-03	t-acc	10 ... 30 s	Allows smooth starting and stopping of the system
P-04	t-dec	10 ... 30 s	
P-06	EnergyOptimizer	1	Energy optimizer enabled. Because of the square fan curve, energy savings can be expected.
P-07	Motor Nom Voltage	...	Enter motor data
P-08	Motor Nom Current	...	
P-09	Motor Nom Frequency	...	
P-12	ProcessDataAccess	5	Selection of the control mode
P-14	Password	101	Allows access to Level 2 of the menu
P-15	DI Config Select	0	Selection of the terminal configuration
P-41	PID1 Kp	0.5 ... 2	Gain and time constant are system dependent.
P-42	PID1 Ti	1 ... 5 s	
P-43	PID1 Mode	0	Direct mode
P-44	PID1 Set Point 1 Source	0	Selection of the digital set point, set with P-45
P-45	PID1 Set Point Digital	...	Enter the necessary value, see also example 1
P-47	AI2 Signal Range	2 (4...20 mA)	Adaptation of Analog Input 2 to the signal of the pressure transducer (4...20 mA)

10.6 Example 6: Supply fan, temperature control, inverse mode

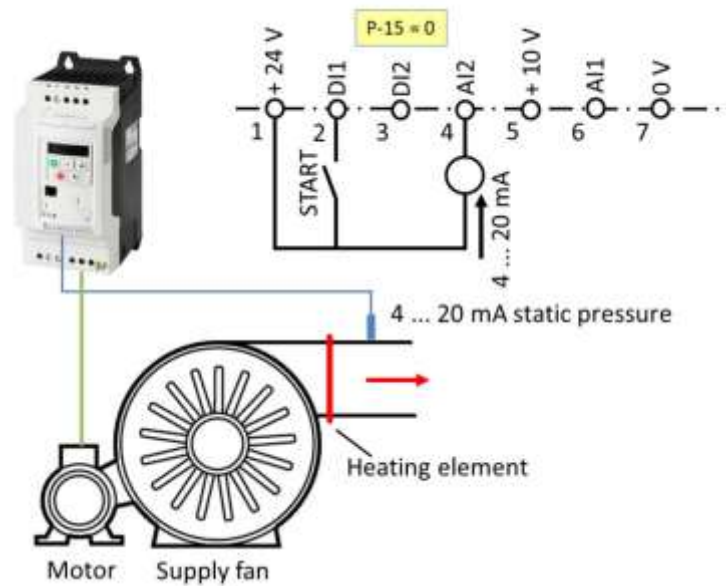

The fixed temperature set point is defined by P-45. The temperature decreases with increasing speed of the supply fan → inverse mode. The following parameters have to be modified compared to default.

Parameter	Name	Value	Remark
P-03	t-acc	10 ... 30 s	Allows smooth starting and stopping of the system
P-04	t-dec	10 ... 30 s	
P-06	EnergyOptimizer	1	Energy optimizer enabled. Because of the square fan curve, energy savings can be expected.
P-07	Motor Nom Voltage	...	Enter motor data
P-08	Motor Nom Current	...	
P-09	Motor Nom Frequency	...	
P-12	ProcessDataAccess	5	Selection of the control mode
P-14	Password	101	Allows access to Level 2 of the menu
P-15	DI Config Select	0	Selection of the terminal configuration
P-41	PID1 Kp	0.5 ... 2	Gain and time constant are system dependent.
P-42	PID1 Ti	1 ... 5 s	
P-43	PID1 Mode	1	Inverse mode
P-44	PID1 Set Point 1 Source	0	Selection of the digital set point, set with P-45
P-45	PID1 Set Point Digital	...	Enter the necessary value, see also example 1
P-47	AI2 Signal Range	2 (4...20 mA)	Adaptation of Analog Input 2 to the signal of the pressure transducer (4...20 mA)

10.7